



# Mapping the services and benefits of indigenous biodiversity and historic heritage in New Zealand

An exploration of spatial datasets

Alison Chick and Ross Laurence

Cover: Lake Hawea, 2014. Photo: © Bernard Spragg.

This report is available from the departmental website in pdf form. Titles are listed in our catalogue on the website, refer [www.doc.govt.nz](http://www.doc.govt.nz) under *Publications*, then *Books, posters and factsheets*

© Copyright May 2016, New Zealand Department of Conservation

ISBN 978-0-478-15068-1 (web PDF)

This report was prepared for publication by the Publishing Team; editing by Amanda Todd and layout by Lynette Clelland. Publication was approved by the Deputy Director-General, Science and Policy Group, Department of Conservation, Wellington, New Zealand.

Published by Publishing Team, Department of Conservation, PO Box 10420, The Terrace, Wellington 6143, New Zealand.

In the interest of forest conservation, we support paperless electronic publishing.

# CONTENTS

Abstract	1
Executive summary	2
1. Introduction	8
1.1 Mapping approaches	8
1.2 Ecosystem services in the context of conservation in New Zealand	10
1.3 Objectives	12
2. Framework	13
3. Methods	15
3.1 Sources of datasets	15
3.1.1 Department of Conservation	15
3.1.2 Other sources	16
4. Stocktake of spatial datasets	17
4.1 Ecological and biodiversity data	17
4.1.1 Terrestrial ecosystems	22
4.1.2 Freshwater ecosystems	23
4.1.3 Estuarine ecosystems	24
4.1.4 Marine ecosystems	24
4.1.5 Discussion	25
4.2 Historic heritage data	27
4.3 Human activities and built infrastructure data	28
4.3.1 Asset Management Information System (AMIS)	28
4.3.2 Permissions Database	32
4.3.3 National Environmental Standards for Sources of Human Drinking Water Database	33
4.3.4 Statistics New Zealand data	33
4.3.5 Discussion	35
4.4 Ecosystem service data	36
4.4.1 Ecosystem Services for Multiple Benefits	36
4.4.2 Mapping the values of New Zealand's coastal waters	38
4.4.3 Ecosystem goods and services in marine protected areas	38
4.4.4 Geodatabase for Mapping Marine Recreational Use and Value	40
4.4.5 Water Bodies of National Importance (WONI)	40
4.4.6 Sustainable Land Use Research Initiative (SLURI), and the Soil and Land Use Alliance (SLUA) —soil natural capital valuation	40
4.4.7 Discussion	43
5. GIS-based ecosystem service assessment tools	45
5.1 Selecting GIS-based tools for conservation purposes in New Zealand	46
5.1.1 LUCI: Land Utilisation and Capability Indicator GIS Toolbox	46
5.1.2 Zonation	47
5.1.3 SeaSketch	48

6.	Case studies	49
6.1	Cultural ecosystem services	50
6.1.1	Nature-based recreation and tourism	50
6.1.2	Identity values	58
6.1.3	Cultural ecosystem services	61
6.2	Historic heritage services	64
6.2.1	Historic heritage values and ecosystem services	65
6.2.2	Mapping historic heritage values	66
6.3	Māori cultural values	68
6.3.1	Māori values and ecosystem services	68
6.3.2	A framework for understanding Māori values and ecosystem services	70
6.3.3	Mapping Māori ecosystem services	72
6.4	Perceived social values of ecosystem services	74
6.4.1	Mapping perceived social values	74
6.5	Services that benefit agricultural and horticultural industries	78
6.5.1	Pest control	78
6.5.2	Pollination of food crops	80
6.5.3	Honey production	83
6.5.4	Soil natural capital	84
6.6	Freshwater ecosystem services	85
6.6.1	Water supply	85
6.6.2	Water quality	88
6.6.3	Water use	92
6.6.4	Social values of freshwater ecosystem services	93
6.7	Marine and estuarine ecosystem services	97
7.	Conclusions	102
8.	Recommendations	105
9.	Acknowledgements	108
10.	References	109
<hr/>		
Appendix 1		
<hr/>		
	GIS-based tools for assessing ecosystem services	126
<hr/>		
Appendix 2		
<hr/>		
	Data categories	132
<hr/>		
Appendix 3		
<hr/>		
	How many people drink water that at least partly originates from lakes whose catchments are dominated by natural land cover?	134

# Mapping the services and benefits of indigenous biodiversity and historic heritage in New Zealand

## An exploration of spatial datasets

Alison Chick<sup>1,2</sup> and Ross Laurence<sup>1,3</sup>

<sup>1</sup> Science & Capability Group, Department of Conservation, Private Bag 4715, Christchurch Mail Centre, Christchurch 8140, New Zealand.

Email: aliathob@gmail.com

<sup>2</sup> Current address: 108 Otaki Street, Kaiapoi 7630, New Zealand

<sup>3</sup> Current address: Landcare Research, PO Box 69040, Lincoln 7640, New Zealand

### Abstract

The Department of Conservation is responsible for conserving indigenous biodiversity and historic heritage in New Zealand. Understanding the many ways that these contribute to our wellbeing will not only draw attention to the importance of their conservation; but it will also aid decision-makers to follow a more holistic decision-making approach in order to achieve greater gains for both conservation and society. With a view of using spatial analysis and Geographic Information Systems (GIS) to inform such decision-making in future, we reviewed spatial data for mapping ecosystem services and historic heritage services at a national level, summarised information on currently available GIS-based ecosystem service assessment tools and how they can be used to further conservation in New Zealand, and explored in greater detail the specific data requirements, information gaps and mapping approaches for selected case studies (cultural ecosystem services, historic heritage services, Māori cultural values, perceived social values of ecosystem services, pest control, pollination, mānuka honey, soil services, freshwater ecosystem services, marine and estuarine ecosystem services).

**Keywords:** conservation, ecosystem service, Geographic Information System (GIS), historic heritage, indigenous biodiversity, spatial analysis, spatial data, mapping, New Zealand

© Copyright May 2016, Department of Conservation. This paper may be cited as:

Chick, A.; Laurence, R. 2016: Mapping the services and benefits of indigenous biodiversity and historic heritage in New Zealand: an exploration of spatial datasets. Department of Conservation, Wellington. 135 p.

# Executive summary

The Department of Conservation (DOC) is responsible for conserving indigenous biodiversity and historic heritage in New Zealand. An increased understanding of the many ways that these contribute to the wellbeing of New Zealanders will help draw attention to the importance of their conservation. This, in turn, will help decision-makers, policy-makers and managers to take these contributions into account when making decisions so that better outcomes can be achieved for conservation and society, both immediately and in the long-term.

The benefits that humans receive from ecosystems are commonly termed ‘ecosystem services’ (MA 2005) and several international initiatives have classified these to aid decision-making. Similarly, we use the term ‘historic heritage services’ to refer to the benefits humans receive from historic heritage. It is important that the full range of ecosystem services and historic heritage services are considered to ensure that decisions, policies and management do not lead to unwanted and unexpected trade-offs, as a decision to enhance one resource, service or value is often at the expense of others. Geographic information systems (GIS) can be effectively used to do this, as problems involving natural heritage, historic heritage and their services, including scenario-testing to identify such trade-offs, are inherently spatial in nature. Therefore, with a view to using GIS for this purpose in the future, in this report we:

- Review spatial data for mapping ecosystem services and historic heritage services at a national level in New Zealand, with a focus on the natural and historic heritage managed by DOC.
- Summarise information on currently available GIS-based ecosystem service assessment tools and how they could be used to further conservation in New Zealand.
- Explore in greater detail the specific data requirements, information gaps and mapping approaches for selected case studies.

## Stocktake of spatial datasets

Internationally, several approaches have been developed to map the supply, use and demand of ecosystem services, including expert knowledge, causal relationships, benefit transfer using lookup tables, extrapolation of primary data, regression models and participatory mapping methods (e.g. see Egoh et al. 2012; Martínez-Harms & Balvanera 2012; Schägner et al. 2012; Crossman et al. 2013). While some services can be quantified and mapped directly, it is often necessary to use these approaches to develop spatially explicit indicators based on readily available data such as land use, land cover, soil, vegetation and nutrient-related data (Egoh et al. 2012).

We focused our stocktake on the following spatial data for terrestrial, freshwater, estuarine and marine ecosystems:

- **Ecological and biodiversity data**—Since different types of ecosystems provide different suites of ecosystem services, spatial data describing ecosystem characteristics (particularly ecosystem classifications) are useful for spatially defining ecosystem services.
- **Historic heritage data**—Spatial data for historic heritage assets and places can be used to estimate the spatial distribution of historic heritage services.
- **Human activities and built infrastructure data**—These data, which include the visitor assets managed by DOC, can be used to develop indicators showing where humans are deriving benefits from natural and historic heritage.
- **Ecosystem service data**—Several ecosystem services have already been mapped at a national level in New Zealand as a result of various research initiatives.

We found that spatial data were most readily available for terrestrial ecosystems and least available for marine and estuarine ecosystems. However, it would be beneficial to improve the resolution of spatial data defining indigenous ecosystems in general.

We identified several major databases for historic heritage in public conservation areas, including ArchSite, DOC's Asset Management Information System (AMIS) and The New Zealand Heritage List. There is scope, however, for improving spatial definitions for historically significant locations, places and assets.

Spatial data for human activities and built infrastructure were most readily available for activities of significance from an economic, political, management, legal or regulatory perspective. Therefore, it is important to carefully consider the appropriateness and limitations associated with using datasets that were created and are maintained for other purposes, such as management or implementing regulations, before using these for quantifying, analysing, modelling or mapping ecosystem services.

Several New Zealand studies and initiatives have included mapping or developing spatial indicators at a national level to address the following services and values: water regulation, supply and quality; erosion control; climate regulation; marine and coastal economic, tourism and identity values; marine, coastal and freshwater environmental and biodiversity values; terrestrial, freshwater, coastal and marine recreation values and/or opportunities; and landscape values. It is not very often, however, that both terrestrial and aquatic ecosystem services are included in the same study. Therefore, there is a need to employ a systems approach to robustly and consistently quantify, analyse and map ecosystem services for all biomes, by recognising the complexity and connectivity of ecosystems and their services, and the fact that services do not adhere to boundaries between biomes and ecosystems.

As is the case in other parts of the world (e.g. see Casalegno et al. 2013), cultural services (with the exception of recreation and tourism) have been poorly addressed, with most studies focussing on provisioning and regulating services. This is of concern, given that cultural ecosystem services represent one of the strongest incentives to support biodiversity conservation (Schaich et al. 2010; Hernández-Morcillo et al. 2013; Satterfield et al. 2013), particularly for people from developed countries (Schaich et al. 2010). To address this gap, several authors (e.g. Schaich et al. 2010; Hermann et al. 2011; Tengberg et al. 2012; Milcu et al. 2013; Church et al. 2014) have suggested that ecosystem services research, which is largely based on natural science paradigms (Tengberg et al. 2012), should better incorporate other disciplines, including the arts and humanities, social sciences, and research on cultural landscapes and their heritage values—especially since cultural services are not purely ecological phenomena but rather the outcome of complex and dynamic, proximal and non-proximal expressive, symbolic, physical and interpretive interactions that people have with ecosystems over space and time (Plieninger et al. 2013; Church et al. 2014).

## GIS-based ecosystem service assessment tools

A range of spatially explicit ecosystem service assessment tools (e.g. ARIES, InVEST, MIMES, SolVES, LUCI) have recently been developed to aid decision-making, particularly for assessing the trade-offs associated with different management scenarios. These have much potential for furthering conservation, including in the following areas:

- **Communication**—Visualising and clearly articulating the possible impacts of resource use decisions and policies on a comprehensive range of values, services and stakeholders.
- **Prioritisation**—Prioritising new areas for protection and restoration, such as retiring marginal lands that are uneconomical to farm but have the potential to not only deliver or improve other non-provisioning ecosystem services (e.g. recreation, erosion and water quality regulation, pollination, pest control, and aesthetic, identity, spiritual and bequest

values), but also conservation gains such as providing corridors for wildlife and achieving greater representation in poorly protected lowland areas.

- **Environmental impact mitigation**—Developing spatially targeted management practices (e.g. riparian plantings) that reduce negative environmental impacts (e.g. erosion, nutrient leaching) and so help managers to operate within environmental limits.
- **Optimising benefits**—Developing management strategies and practices that optimise environmental, social and economic benefits in areas or situations where conservation may not take place unless win-win scenarios can be identified.
- **Partnerships**—Developing management strategies and practices that will result in mutual benefits to all stakeholders in partnership initiatives including businesses, community groups, iwi and conservation organisations.

Although several tools are available, many of these require further customisation and development before they can be applied in New Zealand for conservation purposes. Moreover, with so many tools available, it can be difficult to decide which tool to use and for what purpose (Vigerstol & Aukema 2011). Therefore, a comprehensive analysis should be conducted to understand which tool best matches a particular need. Such an analysis should consider not only ecosystem service assessment tools, but also the possibility of adapting other types of systems and tools that are currently used (e.g. Zonation, SeaSketch, RiVAS) and so already trusted by decision-makers (e.g. see Bagstad et al. 2013).

## Case studies

We investigated the specific data requirements, mapping approaches, information gaps and possible research directions in greater detail for the following case studies:

**1. Cultural ecosystem services**—We discuss mapping nature-based recreation and tourism in public conservation land, and identity values, and then consider how recent research developments in the United Kingdom may be used in New Zealand to develop a multi-disciplinary approach for understanding and mapping cultural ecosystem services in general:

- **Nature-based recreation and tourism**—Visitor use can be used as an indicator for these on public conservation land. For example, a regression model could be used to correlate visitor use data with site accessibility, site infrastructure and amenities, environmental attributes, and potential substitute destinations (see Adamowicz et al. 2011). A more robust, transparent and auditable process for estimating visitation to public conservation land has recently been developed, which is in its early stages of implementation. There is also a need to improve information on visit length, frequency and expenditure; visitor preferences, values and perceptions; and what benefits visitors gain from visiting marine, estuarine, coastal and terrestrial natural environments and conservation areas.
- **Identity values**—Although we know that New Zealand's natural heritage makes a significant contribution to the identity of New Zealanders, a more comprehensive understanding is needed of the relative importance of natural features, natural places and indigenous species to the national, regional and local identities of New Zealanders and various sectors of society. Once this has been achieved (e.g. by using social surveys), identity values could be mapped using readily available spatial data—for example, species distribution data could be used as an indicator for identity values associated with nationally iconic species.
- **UK NEAFO**—As part of the United Kingdom National Ecosystem Assessment Follow-on (UK NEAFO), Church et al. (2014) developed a conceptual framework and four types of spatially explicit indicators for cultural ecosystem services, including supply, accessibility, demand and quality indicators. Similar indicators could be developed for New Zealand—for example, percentage cover of indigenous land cover classes and protected areas could



be used to develop supply indicators; Joyce & Sutton's (2009) Recreation Opportunity Spectrum and Brabyn & Sutton's (2013) population-based assessment of the geographical accessibility of outdoor recreation opportunities could be used for accessibility indicators; and social surveys could be used to inform the development of demand and quality indicators. Further research is needed, however, to develop a more complete understanding of the full range of interactions that people have with natural areas and indigenous species, and which spatially explicit variables influence the supply, accessibility, demand and quality of the places where each of these interactions occur.

**2. Historic heritage services**—Several information gaps need to be addressed before historic heritage values and services can be mapped. These include developing a systematic approach for understanding historic and cultural heritage values for individual places, groups of places and landscapes; developing and assigning physical, historical, cultural and visitor typologies to historic heritage sites; developing spatial definitions for sites and their values; and improving understanding of visitation rates, visitor perceptions and attitudes to historic heritage sites, and other ways in which people interact with historic heritage and the benefits they obtain from these interactions. It is notable that natural and historic heritage values often occur simultaneously in landscapes. It is therefore critical that these approaches, typologies and methods are compatible with ecosystem services research to ensure that a systems approach is used for understanding the values and services associated with the natural and historic heritage managed by DOC.

**3. Māori cultural values**—Several Māori concepts reflect the importance of ecosystems and Waiora (environmental protection) to human wellbeing, including Kaitiakitanga (environmental guardianship) and Whakapapa (genealogical link between humans and ecosystems). To ensure that future decision-making is holistic, and considers the interests and values of all stakeholders, it is critical that Māori knowledge is incorporated into ecosystem services research and assessments. Consequently, there is a need to develop a culturally acceptable mapping approach and a framework for understanding Māori values in the context of ecosystem services and historic heritage services (e.g. by building on Harmsworth's (1998) mapping approach and Harmsworth & Awatere's (2013) Māori ecosystem services framework). Extensive consultation and collaboration with iwi is critical to the success of such work.

**4. Perceived social values of ecosystem services**—To ensure that decisions are made fairly and transparently, it is important that decision makers understand how various ecosystem service beneficiaries value and perceive cultural, provisioning, regulating and supporting ecosystem services, particularly when considering the impacts of particular decisions, policies and management strategies on trade-offs between different beneficiary groups. Unfortunately, measuring and defining these values is challenging as they are often subjective, intangible, emergent, changeable and influenced by many factors—and so they are rarely considered in spatial planning for conservation and environmental management (Brown 2010). However, social surveys, economic valuation, public participation GIS (PPGIS) and other participatory modelling approaches can be used to identify, quantify and map these values. Some of these approaches have been applied in New Zealand to identify and map social values—for example, a geospatial survey tool developed within SeaSketch is being used to inform a spatial planning initiative in the Hauraki Gulf; PPGIS was used to identify landscape values in Otago and Southland (Oyston & Brown 2011; Brown & Brabyn 2012a, b; Hall et al. 2012); and the non-market value of water quality was estimated in Canterbury by combining GIS and a choice experiment (Tait et al. 2012).

#### **5. Services that benefit agricultural and horticultural industries**

- **Pest control**—It is increasingly recognised that landscape and habitat structure has a major influence on pest control services (e.g. Jonsson et al. 2010). Interestingly, the recent Falcons for Grapes project in Marlborough showed that threatened New Zealand falcons (*Falco novaeseelandiae*) are able to provide a pest control service in vineyards (Kross et al. 2012). There may be an opportunity to develop spatially targeted land management practices that not only enhance natural pest control, but also achieve conservation gains by reintroducing

indigenous species or allowing natural vegetation to regenerate in human-modified landscapes. To achieve this, a more comprehensive understanding of the relationship between various spatially explicit variables (e.g. habitat complexity, proximity to natural habitat) and pest control is needed.

- **Pollination**—Although there is growing evidence in New Zealand that native insects provide a pollination service to commercial crops (McAlpine & Wotton 2009), few quantitative data are currently available (Rader et al. 2012). Studies do, however, suggest that the contribution of unmanaged species is significant (sometimes > 50%) and that alternative spatially targeted land management practices can be used to increase their effectiveness (Rader et al. 2009, 2012, 2013). To produce a robust spatially explicit model for pollination that quantifies the relative contribution of native species, we need a better understanding of the spatial distribution, specific resource requirements, and foraging and pollen dispersal distances of native pollinators, as well as their relative effectiveness in pollinating various crops compared with other pollinator species, and the extent to which various spatial and temporal factors influence their efficiency.
- **Mānuka honey**—Data requirements for mapping and quantifying this provisioning service include the spatial distribution of beehives and mānuka (*Leptospermum scoparium*) shrublands, the economic value of mānuka honey, the average volume of honey produced per hive, and the average foraging distance of honey bees (*Apis mellifera*). While sufficient data exist, confidentiality constraints associated with beehive location data would need to be resolved.
- **Soil services**—Mapping and understanding present-day soil natural capital is complex because many soils have been changed or degraded by land managers since human settlement in New Zealand. Therefore, a more comprehensive understanding of historical land use, environmental change, and how these have impacted soil over time and space needs to be developed before the contribution of indigenous biodiversity and ecosystems to soil services can be mapped.

**6. Freshwater ecosystem services**—Spatial analyses are useful for understanding how freshwater supply, quality and use vary over space and time, and the contribution of indigenous biodiversity and ecosystems to these—for example, using Ausseil et al.'s (2013) water yield model, we estimated that 61% of national water yield comes from public conservation land, even though this constitutes only 33% of New Zealand's total land area:

- **Water supply**—Watyield and TopNet are both spatially explicit water balance models that have been tailored to New Zealand conditions. However, the level of distinction between vegetation types needs to be more detailed to produce a more accurate estimate of the contribution of indigenous biodiversity and ecosystems to water supply.
- **Water quality**—Water quality has been mapped at a national level for lakes, groundwater and rivers in New Zealand. Regression models could be used to test the effect of spatially explicit variables of interest to conservation (e.g. percentage catchment protected as public conservation; percentage catchment covered with indigenous vegetation) on water quality in New Zealand.
- **Water use**—Spatial data on water use and allocation is available from Water Information New Zealand (WINZ), the National Environmental Standards for Human Drinking Water Database and regional authorities. The Ministry for the Environment produced a map of potential surface water allocation pressure in 2010, which showed which catchments may have been at risk of surface water allocation pressures during dry periods and so may require further investigation for management options. Understanding the spatial coincidence of freshwater supply, quality, use and pressures is important to ensure the long-term sustainability of this resource.

**7. Marine and estuarine ecosystem services**—Marine ecosystem services have been explored spatially at a national level by several projects (e.g. Beaumont et al. 2008, 2009; Allen et al. 2009; Batstone et al. 2009; Samarasinghe et al. 2009; Visitor Solutions Ltd et al. 2012), but this work has often focussed on areas near the coast. Among other reasons, this may be due to the sheer size of the wider marine environment, variability in the availability and quality of data, a lack of suitable indicators, and difficulties in collecting primary data due to accessibility constraints. Estuaries provide a disproportionately large number of services compared with other environments (Costanza et al. 1997). However, until estuaries themselves have been properly defined spatially—which is currently being addressed by several initiatives—their ecosystem services cannot be mapped at a national level.

Credible and creative solutions are being developed for mapping marine and estuarine services, however, based on existing information and expert opinion. When mapping these services, it is important to recognise the importance of connectivity in the processes and functioning of these ecosystems; and that marine and estuarine ecosystems are subject to a broad range of stressors that can be terrestrial, marine or global in origin. Future research could focus on further developing existing approaches that have the potential to be used for national level mapping, such as the Ecological Principles Approach (Townsend & Thrush 2010; Townsend et al. 2011, 2012, 2014b) and Townsend et al.'s (2014a) matrix approach. In addition, the real and future potential role of indigenous coastal ecosystems in providing ecosystem services in relation to climate change and other stressors could be modelled and mapped.

## Conclusions

Our information review and case studies revealed a large number of challenges relating to data availability, discoverability, quality, confidentiality and ownership. While some services require considerable further work, others can be mapped using existing data and current understanding—and several projects and initiatives have demonstrated that creative and credible solutions can be developed even when confronted by significant challenges.

While many approaches can often be used to map a particular service, it is essential that the chosen method is fit for purpose. If the goal is to gain a high-level view of service supply, demand, pressures and trends to inform national policies and decisions, then it is critical that a consistent framework and approach that employs systems thinking is used to quantify, map and analyse services across all biomes. In addition, it is crucial that spatial data, models and accompanying guidelines for proper use are discoverable, accessible and usable to ensure that these can effectively support future local-, regional- and national-level decision-making in the private and public sectors.

Although this report focuses on services of relevance to natural and historic heritage managed by DOC, the services and benefits provided by exotic biodiversity, human-modified ecosystems and other historic heritage should also be considered to ensure that decision-making is holistic and transparent.

We conclude that there is considerable scope for mapping services at a national level in New Zealand through greater collaboration between a wider range of disciplines and stakeholders. Such data and the use of spatially explicit ecosystem service tools offer great potential to support future decision-making, leading to better outcomes for both society and conservation.

# 1. Introduction

Ecosystems and biodiversity impact on various aspects of human wellbeing (MA 2005), including health, livelihood and survival (de Groot et al. 2012). The benefits that humans receive from the environment are commonly termed ‘ecosystem services’, and an understanding of these services is important if we are to uncover the hidden social benefits and costs that result from environmental management or mismanagement (Troy & Wilson 2006). There has been increasing interest at an international level to quantify and assess ecosystem services (Costanza et al. 1997; Troy & Wilson 2006) so that their value can be taken into account in economic valuations, environmental management, land use planning and policy. This has led to the development of several ecosystem service classifications, including the Millennium Ecosystem Assessment (MA)<sup>1</sup>, The Economics of Ecosystems and Biodiversity (TEEB)<sup>2</sup>, the Common International Classification of Ecosystem Services (CICES)<sup>3</sup> and the United Kingdom National Ecosystem Assessment (UK NEA)<sup>4</sup>. In this report, we broadly use the MA’s (2005) definition of ecosystem services, but with a focus on indigenous biodiversity and ecosystems:

*Ecosystem services are the benefits which people obtain from biodiversity and ecosystems. These include supporting, regulating, provisioning and cultural services.*

## 1.1 Mapping approaches

Spatial analyses using geographic information systems (GIS) are recognised as an effective method for defining and quantifying ecosystem services (e.g. Troy & Wilson 2006; Chen et al. 2009; Kareiva et al. 2011; Sherrouse et al. 2011; Swetnam et al. 2011; Brown et al. 2012). Consequently, spatial analyses are often incorporated into ecosystem service assessments—in Europe, for example, Member States of the European Commission are being encouraged to respond to the call of the EU Biodiversity Strategy to 2020 to map and assess the state of ecosystems and their services (Maes et al. 2013). A major conceptual advantage of the ecosystem services approach has been the development of spatially explicit trade-off analysis techniques (Schaich et al. 2010; Tengberg et al. 2012). Spatial analyses are also useful to compare ecosystem service supply and demand, which may vary geographically, to ensure that demand does not exceed supply in any particular area (Burkhard et al. 2012; Crossman et al. 2013; ); and they also allow the identification of hotspots<sup>5</sup> (Raymond et al. 2009) and places where different types of values coincide spatially. Consequently, multiple management objectives, including economic, environmental and social goals, can be achieved at one site (Raymond et al. 2009), and targeted land use changes can be made to cost-effectively maximise the provision of ecosystem services in a landscape (Crossman & Bryan 2009).

Several approaches have been developed to map ecosystem services, including:

- **Expert knowledge:** This can be used to rank land cover (Martínez-Harms & Balvanera 2012) and other available data on their potential to provide a particular ecosystem service.
- **Causal relationships:** Existing documented knowledge about the relationship between known environmental data layers and ecosystem service supplies can be used to create new proxy layers of ecosystem services (Martínez-Harms & Balvanera 2012).

---

<sup>1</sup> [www.unep.org/maweb/en/Index.aspx](http://www.unep.org/maweb/en/Index.aspx) (accessed 8 July 2013).

<sup>2</sup> [www.teebweb.org/resources/ecosystem-services](http://www.teebweb.org/resources/ecosystem-services) (accessed 8 July 2013).

<sup>3</sup> <http://cices.eu> (accessed 8 July 2013).

<sup>4</sup> <http://uknea.unep-wcmc.org> (accessed 8 July 2013).

<sup>5</sup> In this context, a particular location may be a hotspot for ecosystem services in general if survey participants in a participatory mapping project identify it as being important for a relatively high number of value or service types (e.g. an estuary may be important for fishing, identity, bird-watching, water quality, spiritual values, etc.). Alternatively, a particularly high number of participants may identify a particular location as being important for a particular service (e.g. a look-out spot in a forest may be an aesthetic values hotspot).

- **Lookup tables:** Early ecosystem service valuation work (e.g. Costanza et al. 1997) used the benefit-transfer approach (Daily et al. 2011), which assesses existing ecosystem service values based on literature and transfers them from one location to another based on land cover classes that can then be mapped. For example, Costanza et al. (2014) transferred empirical value estimates of goods and services produced from particular ecosystem types to similar ecosystems elsewhere in the world, and then produced a global map of ecosystem service values per hectare (Costanza et al. 2014). In New Zealand, Patterson & Cole (1999) also used the benefit-transfer method to estimate the dollar value of ecosystem services for various ecosystems in New Zealand, and have since updated and refined these estimates by eliminating double counting, particularly of supporting services, and by reconfiguring the framework to be compatible with the MA (Patterson & Cole 2013).
- **Extrapolation of primary data:** Primary data from relatively few information sources can be extrapolated to larger areas based on land cover data and then adjusted to the particularities of the study area (Martínez-Harms & Balvanera 2012). However, any error needs to be estimated and explained to make this process more robust and defensible.
- **Regression models:** Ecological production functions and regression models may be based on causal combinations of explanatory variables or indicators. These models may be grounded in expert opinion and/or known ecological principles, or validated via calibration with primary or secondary data (Schägnner et al. 2012). For example, InVEST is a suite of ecosystem service models based on production functions, which predict ecosystem service supply based on land cover, land use, ecosystem attributes, human demand and other available data (see Kareiva et al. (2011) and Appendix 1).
- **Participatory mapping methods:** These can be used to map social values and human perceptions of ecosystem services by conducting workshops or interviews, or via web-based crowdsourcing applications (e.g. Tyrväinen et al. 2007; Raymond et al. 2009; Bryan et al. 2010; Raymond & Brown 2011; Davies 2012; Plieninger et al. 2013).

Ecosystem service mapping tools use some of the methods described above, and can be used to assess ecosystem services and trade-offs associated with different management scenarios (see Appendix 1). These methods employ a variety of data types, including biophysical (e.g. land cover, topographic, hydrological, climate and soil) and socioeconomic (e.g. population, census and built infrastructure) data (see Martínez-Harms & Balvanera 2012); as well as public perception and social survey data (e.g. Tyrväinen et al. 2007; Raymond et al. 2009; Bryan et al. 2010; Raymond & Brown 2011; Davies 2012; Plieninger et al. 2013; Sherrouse et al. 2011; Sherrouse & Semmens 2012; van Riper et al. 2012). Furthermore, although using primary data (data collected by the user for a specific purpose, such as field data, surveys, interviews and census data) is ideal, secondary data (readily available data that was originally collected or compiled by someone other than the user, such as land cover and topographic data) have been widely used (e.g. see Martínez-Harms & Balvanera 2012).

Ecosystem service mapping methods have recently been reviewed by several authors (Egoh et al. 2012; Martínez-Harms & Balvanera 2012; Schägnner et al. 2012; Crossman et al. 2013). Martínez-Harms & Balvanera (2012) found that causal relationships are most commonly used to map ecosystem services, followed by the extrapolation of primary data; and that secondary data are more commonly used than primary data, especially for regulating services (Crossman et al. 2013). Similarly, Egoh et al. (2012) found that proxy methods are most commonly used to map and quantify ecosystem services, with the most common indicators being land use, land cover, soils, vegetation and nutrient-related indicators. Crossman et al.'s (2013) review built upon those by Martínez-Harms & Balvanera (2012) and Egoh et al. (2012), and found that the most commonly mapped ecosystem services are climate regulation, recreation and tourism, food production, water supply, and the regulation of water flows. Villa et al. (2011) also pointed out that few mapping studies explore human demand for and use of ecosystem services alongside service provision—possibly because supply and demand often occur across different temporal and

spatial scales, making mapping complex. Table 1 provides examples of primary and secondary indicators that can be used to quantify and map ecosystem services.

Different mapping methods have their strengths and weaknesses which need to be considered to ensure that the chosen method is appropriately matched with the intended purpose. For example, some approaches are too simplistic (e.g. those based largely on proxy categorical information such as land cover classes) in that they do not sufficiently account for the fact that ecosystem service provision, use and flow are complex and dynamic at multiple scales (Villa et al. 2011). The limited accuracy of such approaches therefore impedes their usage in quantitative, spatially explicit scenario analysis; and restricts their ability to inform decisions (Villa et al. 2011). Similarly, Martínez-Harms & Balvanera (2012) also cautioned against over-simplified modelling techniques for fear that they may mislead decision makers. Instead, they promoted the use of regression models, as these enable explanatory variables to be identified, uncertainty to be assessed, and comparisons to be made across time and space, allowing for a more comprehensive understanding of the social-ecological processes behind ecosystem service supply, demand and use. Furthermore, model validation is also needed for resolving errors and improving the overall quality of models (see Martínez-Harms & Balvanera 2012).

There is also a need to standardise service definitions, mapping methods and the way in which metadata are recorded to enable comparison between studies (Maes et al. 2013), including within and between countries and over time. Decision-making and policy would also be better informed if ecosystem service quantification and mapping methods were more defensible, robust and accurate (Crossman et al. 2013). Indeed, policies based on the commodification of ecosystem service production, such as the New Zealand Emissions Trading Scheme<sup>6</sup>, can only be successful if there is certainty among participants that measurement techniques are robust and comparable (Crossman et al. 2013). The fairly recent development of a range of decision-support ecosystem service assessment tools by various researchers and initiatives (see Appendix 1) are intended to enable replicable, quantifiable and robust ecosystem service analyses—unlike the *ad hoc* methods that have often been used previously (Bagstad et al. 2013).

## 1.2 Ecosystem services in the context of conservation in New Zealand

The Department of Conservation (DOC) is interested in exploring the ecosystem services concept to further the conservation of both natural and historic heritage in New Zealand. It is hoped that an increased understanding of the services and benefits provided by these will lead to increased recognition of the importance of conservation in general. It should be noted, however, that there is no intention of using ecosystem services as the sole rationale for conservation. Rather, the ecosystem services approach can be used to provide additional reasons for conservation **on top of** the traditional rationale (e.g. the intrinsic values of biodiversity)—conservation imperatives described in legislation remain the primary context for DOC's decision-making, but it is nevertheless important to measure the wider benefits (and costs) of decisions.

The concept of ecosystem services is reflected in DOC's outcomes model (see Fig. 1), which acknowledges the environmental, social and economic benefits that New Zealanders gain from the natural and historic heritage managed by DOC. In particular, its outcome statement draws attention to the environmental, social and economic benefits gained from healthy functioning ecosystems and historic heritage. Recognition of these services and benefits will contribute towards DOC achieving all five of its intermediate outcomes and, ultimately, its overall vision.

---

<sup>6</sup> [www.climatechange.govt.nz/emissions-trading-scheme](http://www.climatechange.govt.nz/emissions-trading-scheme) (accessed 8 July 2013).

Table 1. Examples of primary and secondary indicators or variables that are used to map ecosystem services (based on information presented by Crossman et al. (2013) and Egoh et al. (2012)).

ECOSYSTEM SERVICE	PRIMARY INDICATOR*	SECONDARY INDICATOR†
<b>Regulating services</b>		
Air quality regulation	Air pollution removal by trees	<ul style="list-style-type: none"> <li>• Tree cover, leaf area index, weather data, deposition velocity, pollutant concentrations</li> </ul>
Climate regulation	Carbon storage and sequestration	<ul style="list-style-type: none"> <li>• Field measurements of different land cover types, above- and below-ground biomass, land cover, nutrient flux, soil carbon and characteristics, climate, vegetation growth and characteristics, remotely-sensed net primary productivity</li> </ul>
Flood control	Water retention capacity Flood magnitude	<ul style="list-style-type: none"> <li>• Vegetation cover, soil type</li> <li>• Hydrology (runoff), topography, geology, soil, vegetation, management practices</li> </ul>
Water flow regulation	Maintenance of natural irrigation and drainage; buffering of extreme river discharges; regulation of channel flows; hydrological flow	<ul style="list-style-type: none"> <li>• Ground and surface water, soil and water characteristics, vegetation, land use, land cover, topography, stream flow, precipitation, water use</li> </ul>
Waste treatment	Nutrient and sediment retention by vegetation and upstream freshwater systems	<ul style="list-style-type: none"> <li>• Soil erosion models, hydrology indicators, agricultural input indicators, crop productivity indicators, topography, soil type, land cover</li> </ul>
Erosion control	Soil loss and retention	<ul style="list-style-type: none"> <li>• Vegetation cover, land cover, land use, topography, soil erodibility and characteristics, water flow (universal soil loss equation is commonly used)</li> </ul>
Soil fertility maintenance	Soil fertility, productivity or organic content	<ul style="list-style-type: none"> <li>• Soil and land cover variables (e.g. soil depth and litter depth)</li> </ul>
Pollination	Pollination	<ul style="list-style-type: none"> <li>• Land cover, land use, pollinator habitat, crop yield, pollinator abundance, climate, foraging and pollen dispersal distances</li> </ul>
Pest control	Pest density	<ul style="list-style-type: none"> <li>• Land cover</li> </ul>
<b>Provisioning services</b>		
Food production	Land use, soil, climate, production statistics	
Water supply	Volume water yield	<ul style="list-style-type: none"> <li>• Precipitation, actual and potential evapotranspiration, land cover, soil water holding properties, surface and groundwater, daily runoff simulated using hydrological models and calibrated with daily precipitation and stream gauge data</li> </ul>
Raw materials	Volumes of products Level of harvest by region or community	<ul style="list-style-type: none"> <li>• Spatially explicit harvest or extraction volumes</li> <li>• Household demographic and labour data, location attributes, resource (e.g. forest) type</li> </ul>
Genetic, medicinal and ornamental resources	Medicinal plants	<ul style="list-style-type: none"> <li>• Land cover</li> </ul>
<b>Cultural services</b>		
Aesthetic	Scenic beauty Landscape attractiveness Real-estate with natural views	<ul style="list-style-type: none"> <li>• Questionnaires and interviews on personal preference</li> <li>• Naturalness, skyline disturbance, viewshed</li> <li>• Price people are willing to pay for a property with a view</li> </ul>
Recreation and tourism	Visitor use	<ul style="list-style-type: none"> <li>• Visitor/user numbers and statistics (e.g. no. kills/catches, no. overnight stays), landscape attributes (e.g. naturalness, attractiveness, land cover), accessibility, amenities/facilities (e.g. accommodation, roads), distance to resources, target species abundance, industries, population density</li> </ul>
Inspiration for culture, art and design	Cultural heritage values	<ul style="list-style-type: none"> <li>• Land use, land cover</li> </ul>
<b>Supporting/habitat services</b>		
Life cycle maintenance	Habitat suitability for species	<ul style="list-style-type: none"> <li>• Species distributions, soil characteristics, topography, climatic variables, land use, land cover</li> </ul>
Maintenance of genetic diversity	Biodiversity hotspots (with high endemism)	<ul style="list-style-type: none"> <li>• Species distributions, soil characteristics, topography, climatic variables, land use, land cover</li> </ul>

\* These reflect the proxy used to measure a particular ecosystem service (Egoh et al. 2012).

† These provide the necessary information to develop each primary indicator (Egoh et al. 2012).



Figure 1. The Department of Conservation's (DOC's) outcomes model.

### 1.3 Objectives

In this project, we explored the availability of data and its potential use for mapping, analysing and quantifying the services and benefits provided by natural and historic heritage administered by DOC. Specifically, we aimed to:

- Identify and, where possible, gather spatial datasets that could be used to map these services
- Identify knowledge and data gaps
- Discuss possible mapping approaches and potential future uses
- Recommend areas for future work and analysis

To do this, the report begins in sections 2 & 3 with an explanation of the framework and methods that we used. This is followed in sections 4 & 5 with an overview of spatial datasets and a selection of GIS-based tools that are currently available for spatially defining and assessing ecosystem services. Section 6 then presents a wide range of case studies, which investigate the specific data requirements for mapping each service type. Finally, conclusions and recommendations are presented in sections 7 & 8.

It is hoped that this report will help make information about future mapping options for indigenous biodiversity and historic heritage more available to decision makers, DOC and other natural resource sector agencies, and members of the general public. This is one of several projects commissioned by DOC that aim to build a foundational knowledge of natural capital and ecosystem services for New Zealand. Knowledge generated from these projects will be used to provide technical expertise, support and information for DOC partnerships, policy, land management, communication (both within and external to DOC), engagement, scientific research, and operational conservation work. Although we largely adopt a DOC perspective, this report is also applicable to a wider audience.

<sup>7</sup> Lee et al. (2005) defined indigenous dominance as 'the level of indigenous influence on the composition, structure, biomass, trophic and competitive interactions, mutualisms, and nutrient cycling in a community'.



The greater goal is to use ecosystem services as a tool to further conservation by helping decision makers, policy makers, land managers, businesses and New Zealanders to view conservation as an essential part of their identity, wellbeing and prosperity. It is hoped that this work will help to improve understanding and management of the services and benefits provided by both indigenous species and ecosystems, as well as the historic heritage administered by DOC.

## 2. Framework

Figure 2 illustrates the framework used in this report for understanding how the natural and historic heritage managed by DOC contributes to the wellbeing of New Zealanders.

It is useful to use a single framework to address both natural and historic heritage because DOC is responsible for the management of both. We have treated the contributions made by historic and natural heritage as separate streams, however, to illustrate the importance of DOC's role in their management.

We use the term 'ecosystem services' to describe the benefits people obtain from biodiversity and ecosystems (MA 2005). While our framework focuses on indigenous biodiversity and ecosystems with indigenous dominance<sup>7</sup> (hereafter 'indigenous/natural ecosystems'), it also recognises that services and benefits can sometimes result from an interaction between indigenous and exotic biodiversity, and also indigenous ecosystems and human-modified ecosystems with little or no indigenous dominance (e.g. urban and agricultural ecosystems; hereafter 'human-modified ecosystems')—although the services provided by exotic species are often underpinned by services provided by indigenous biodiversity and ecosystems (see sections 6.5 & 6.6). Beyond this, exotic biodiversity and human-modified ecosystems are otherwise beyond the scope of this report. It is important that decision makers recognise and consider the services and disservices provided by both exotic and indigenous biodiversity, and indigenous and human-modified ecosystems, however, to ensure that decision-making is holistic and that a comprehensive range of trade-offs can be identified.

In line with our chosen definition for ecosystem services, we use the term 'historic heritage services' to describe the benefits (e.g. recreation, tourism, identity values, bequest values) people obtain from the historic heritage managed by DOC.

In addition to managing natural and historic heritage, DOC also manages a large number of visitor assets (e.g. huts, tracks)—these are treated as a built infrastructure investment that facilitates and enhances the benefits that humans receive from natural and historic heritage.

Human perceptions and cultural/social values cross-cut other components of the framework as these influence and are influenced by human interactions with natural and historic heritage, and the contribution of these interactions to human wellbeing. This component of the framework was influenced by concepts included in Harmsworth & Awatere's (2013) Māori ecosystem services framework and Church et al.'s (2014) conceptual framework for cultural ecosystem services.

Figure 2 also provides examples to illustrate different aspects of our framework. These were selected to represent different types of services (i.e. provisioning, regulating, cultural, supporting and historic heritage services), various biomes (i.e. terrestrial, freshwater, estuarine and marine) and other framework components. We develop these examples into case studies in section 6 of this report.

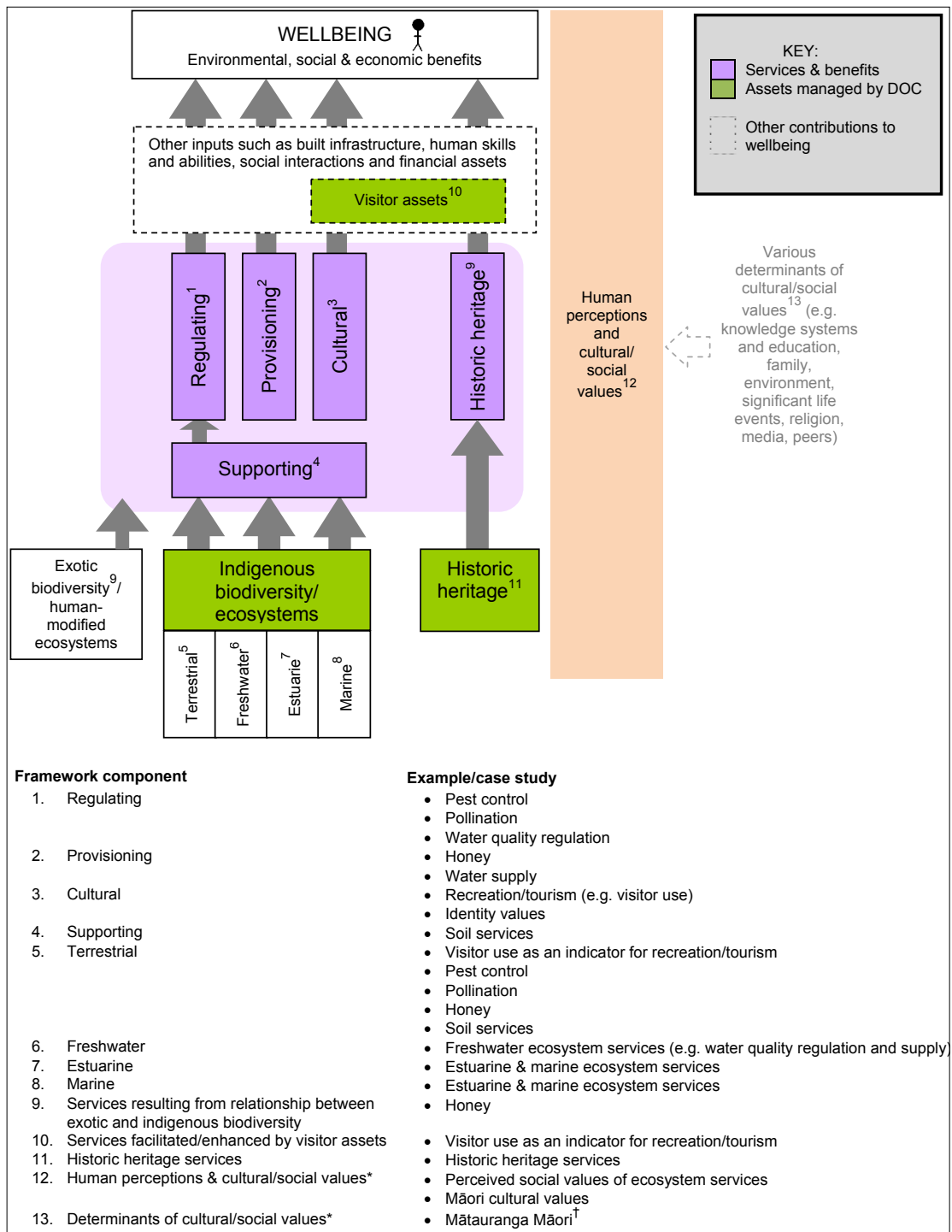

\* These components of the framework were influenced by concepts included in Harmsworth & Awatere's (2013) Māori ecosystem services framework and Church et al.'s (2014) conceptual framework for cultural ecosystem services.

† Mātauranga Māori can be defined as 'the knowledge, comprehension or understanding of everything visible or invisible that exists across the universe' (Marsden 1988), including Māori knowledge systems and wisdom (Harmsworth & Awatere 2013).

Figure 2. Framework for understanding how the natural and historic heritage administered by the Department of Conservation (DOC) contributes to the wellbeing of New Zealanders. DOC also manages visitor assets (e.g. huts, tracks), which are treated as a built infrastructure investment that facilitates and enhances the benefits humans receive from natural and historic heritage. The following examples are selected to illustrate each component (indicated by numbers) of the framework and are developed into case studies in section 6 of this report: cultural services (3) (e.g. recreation/tourism (3) with visitor use (3,5,10) as an indicator, identity values (3)); historic heritage services(11); Māori cultural values (12); perceived social values of ecosystem services (12); services provided by indigenous biodiversity that benefit agricultural and horticultural industries, including pest control (1,5), pollination (1,5), mānuka honey (2,5,9) and soil services (4,5); freshwater ecosystem services(6) (e.g. water quality regulation(1,6) and supply (1,2)); and estuarine (7) and marine (8) ecosystem services.

## 3. Methods

We began by carrying out a general stocktake of spatial datasets that are of relevance to ecosystem and historic heritage services (section 4). To do this we:

- Investigated the websites of government departments, regional councils, Crown Research Institutions (CRIs) and non-government organisations
- Reviewed published scientific literature on ecosystem services in New Zealand
- Contacted key experts and data holders both within and external to DOC
- Compiled a list of relevant online data portals and then systematically browsed these for relevant datasets

We organised these databases and data portals according to data type (ecological and biodiversity, historic heritage, human activities and built infrastructure, ecosystem service), scale and 19 ecosystem service categories (see Appendix 2) in an Excel spreadsheet (see Data Supplements 1 & 2<sup>8</sup>). The 19 ecosystem service categories were not necessarily based on any particular ecosystem service typology, such as that of the MA, CICES, TEEB or UK NEA; rather, they were divided into categories that best described the data and would make the databases easy to use in the future. We also entered brief descriptions of these datasets (including where they can be sourced) into the spreadsheet and, where possible, described limitations associated with using the datasets to map the services and benefits provided by indigenous biodiversity and historic heritage. If the data were of immediate use, or if more detailed examination was necessary to determine their relevance to ecosystem services, we gained access to them where possible. Where datasets were subject to use restrictions in order to protect intellectual property and/or privacy rights, a written data-sharing contract was agreed to by both parties—and sometimes a monetary cost was also incurred. It should be noted that it was beyond the scope of the project to examine all datasets and their limitations in great detail due to access limitations, resource constraints, etc. Moreover, the entire process of identifying, accessing, exploring and organising the datasets was time-consuming, primarily because it involved searching many disparate sources. Consequently, the list of datasets included in this report is not exhaustive because some datasets were discovered only by chance, and so there will inevitably be others; not all datasets were publically available; and some relevant datasets may have been created for other purposes and so have not been specifically linked to ecosystem or historic heritage services.

We also collated information on selected GIS-based tools that are currently available for mapping and analysing ecosystem services (section 5 and Appendix 1).

We then investigated the data requirements, data availability and potential approaches for mapping specific services (section 6). We based these case studies on the examples identified in Fig. 2, which illustrate different components of our framework (see section 2). These examples were also chosen for their relevance to topical issues and current research, significance to conservation and New Zealand's economy, and to illustrate a range of data intensities, availabilities and/or complexities. It should be noted, however, that other examples could equally have been chosen.

### 3.1 Sources of datasets

#### 3.1.1 Department of Conservation

DOC has implemented a GIS infrastructure known as the National Enterprise Geospatial Information System (NEGIS), which houses national-, regional- and conservancy-level<sup>9</sup> GIS data. Since this project focused on national datasets, the information stored in the national servers

---

<sup>8</sup> These Data Supplements are available for download from the DOC website (in conjunction with this report) as searchable Excel databases (<http://www.doc.govt.nz/about-us/science-publications/books-posters-and-factsheets/reports-and-books/>).

<sup>9</sup> DOC conservancies have now been replaced by new regional and district administrative boundaries.

NATIS 1 (DOC data), NATIS 2 (external data) and NATIS 3 (imagery) were of most relevance. Other sources included the Christchurch and Wellington GIS and Shared network drives, and DOC's information management systems (e.g. Asset Management Information System—AMIS).

The ability to identify, collect and assess DOC datasets was impacted by the lack of a comprehensive central data-sharing system spanning all DOC offices. For example, until recently, bat monitoring data were held in various conservancy spreadsheets, preventing a national view of their distributions (DOC 2013a). Projects are currently underway to address these issues, but it is a large task—for example, in the case of the bat monitoring data, it took one person 6 months to collect and make the data accessible at a national level (Benno Kappers, DOC, pers. comm.). Consequently, collating office-level data was beyond the scope of this project.

### 3.1.2 Other sources

#### *Regional*

In New Zealand, there are 67 territorial authorities and 16 regional councils, all of which collect spatial data that are of relevance to ecosystem services, such as the locations of natural resource consents. Unfortunately, we were unable to investigate the data from all of these due to time and resource constraints. Instead, relevant GIS data from Environment Canterbury<sup>10</sup> were examined and summarised to provide examples of the types of relevant data that regional councils hold. A more detailed survey and collection of data held by regional authorities could be carried out in the future.

#### *National*

There are several web-based, government-run national data portals and information services in New Zealand, including data.govt.nz, Satisphere and geodata.govt.nz. Many government and private organisations also have web-based information sharing facilities. These were explored as potential data sources. In addition, research projects and programmes were investigated to determine whether they yielded any relevant spatial data or information.

There has recently been a move to improve data sharing at a national level within New Zealand. In 2009, a report commissioned by Land Information New Zealand (LINZ), DOC and the Ministry of Business, Innovation and Employment (MBIE) showed that the use of spatial information in New Zealand added \$1.2 billion in productivity-related benefits to the economy, but that a further potential \$481 million was lost due to barriers to the adoption of spatial information (McEntee 2009). These barriers included accessibility, inconsistencies in data standards, and skill and knowledge shortages. To improve this, the Open Government Information and Data Work Programme<sup>11</sup> has been working with public sector agencies on improving data sharing and accessibility since its initiation in 2008; and in 2013, DOC hosted the Greatest Living Space Symposium<sup>12</sup> (16–17 April 2013, Wellington), a major goal of which was to facilitate networking and discuss data sharing.

#### *International*

Many other countries have also recognised the importance of sharing spatial data, and have invested in the development of Spatial Data Infrastructures (SDIs) to improve access and sharing (Strain et al. 2006). This recognition has also resulted in the development of international data sharing networks and facilities, such as the Global Biodiversity Information Facility (GBIF), the Group on Earth Observations Biodiversity Observation Network (GEOBON) and Koordinates.com

---

<sup>10</sup> Environment Canterbury was selected as it was the most accessible, given that the authors are based in Canterbury.

<sup>11</sup> <https://ict.govt.nz/programmes-and-initiatives/open-and-transparent-government/open-government-information-and-data-work-programm> (accessed 8 September 2014).

<sup>12</sup> [www.doc.govt.nz/about-doc/role/maps-and-geospatial-services/natural-resource-group-gis-network](http://www.doc.govt.nz/about-doc/role/maps-and-geospatial-services/natural-resource-group-gis-network) (accessed 8 September 2014).

(see Data Supplement 2<sup>8</sup>). In general, the sharing of marine spatial data has lagged behind that of terrestrial spatial data (Strain et al. 2006), although this is being addressed with the emergence of specialist marine data-sharing facilities such as Ocean Biogeographic Information System (OBIS) and the United Nation Environment Programme World Conservation Monitoring Centre’s (UNEP-WCMC’s) Ocean Data Viewer.

## 4. Stocktake of spatial datasets

The datasets, data sources, data portals and information services that were identified as being relevant for mapping the services and benefits provided by the natural and historic heritage administered by DOC are summarised in the following data supplement files published along with this report on the DOC website:

- Data Supplement 1: Datasets and data sources
- Data Supplement 2: Data portals and information services

In this section, we summarise our findings from this stocktake using the data types and biome categories defined in Appendix 2:

<b>Data type</b>	<b>Biomes</b>
1. Ecological and biodiversity	1. Terrestrial
2. Historic heritage	2. Freshwater
3. Human activities and built infrastructure	3. Estuarine
4. Ecosystem service	4. Marine

The exploration of data within data type categories 1–3 was considered an important initial step, as this would provide baseline data for future mapping of ecosystem services and historic heritage services. Ecological and biodiversity data (including biophysical data) can be used as proxies or predictor variables to estimate the spatial distribution of ecosystem service provision (see section 1.1). Similarly, spatial data for historic heritage assets and places can be used to estimate the spatial distribution of historic heritage services; and data on human activities and built infrastructure can be used to predict and map where people are receiving benefits from natural and historic heritage. The final data type category (ecosystem service) refers to spatial data that have already been created to represent the spatial distribution of ecosystem services and benefits at a national level.

Although datasets were categorised into four biomes, it is important to note that these biomes are connected and that many ecosystem services transcend the boundaries between them. For example, seabirds transfer nutrients from marine to terrestrial environments; and similarly, the erosion control, nutrient retention and habitat services provided by riparian vegetation influence aquatic services such as the provision of clean drinking water, healthy fisheries and swimming.

It should also be noted that the information presented in this section and the accompanying data supplements is not exhaustive. Rather, this report should be treated as a starting point for further research, as some relevant datasets or gaps may not have been identified, and new datasets are continually being created and/or made more discoverable and accessible.

### 4.1 Ecological and biodiversity data

We investigated the availability of environmental and ecosystem classification data (Table 2) and biodiversity data (Table 3) for terrestrial, freshwater, estuarine and marine ecosystems (see Fig. 3 for mapped examples for each biome). Such data can be used to predict and map the spatial distribution of ecosystem services—for example:

Table 2. Summary of the availability of spatial environmental and ecosystem classification data, including names of the relevant organisations. Note: Although land cover and landscape classifications such as the Land Cover Database (LCDB) and New Zealand Landscape Classification are only included under terrestrial ecosystems, these also have aquatic components. See Data Supplements 1 & 2\* for more detail on specific datasets.

BIOME	ORGANISATION	DATA
<b>Terrestrial</b>		
	AsureQuality	<ul style="list-style-type: none"> <li>• AgriBase</li> </ul>
	Department of Conservation (DOC)	<ul style="list-style-type: none"> <li>• Ecosystem Optimisation Project data (Leathwick &amp; Wright 2011; Leathwick et al. 2012a)</li> <li>• Historically rare ecosystems spatial data—in preparation</li> </ul>
	DOC; Landcare Research	<ul style="list-style-type: none"> <li>• Vital Sites and Actions Model (Overton et al. 2010)</li> </ul>
	Institute of Geological and Nuclear Sciences (GNS)	<ul style="list-style-type: none"> <li>• Geological data (e.g. minerals, rock aggregates, coal, oil, gas) such as QMap</li> </ul>
	Land Information New Zealand (LINZ)	<ul style="list-style-type: none"> <li>• Topographic data</li> </ul>
	Landcare Research	<ul style="list-style-type: none"> <li>• Basic Ecosystems (Dymond et al. 2013a)</li> <li>• Ecosat Basic Land Cover</li> <li>• Ecosat Forests</li> <li>• Ecosat Woody (Dymond &amp; Shepherd 2004)</li> <li>• Fundamental Soil Layer (FSL)</li> <li>• Generalised Dissimilarity Modelling (GDM) Terrestrial Ecosystem Classification (Overton et al. n.d.)</li> <li>• Land Cover Database (LCDB; Steve Thompson &amp; Partners n.d.)</li> <li>• Land Use of New Zealand (LUNZ 2011)</li> <li>• New Zealand Land Resource Inventory (NZLRI)</li> <li>• Potential Vegetation of New Zealand (Leathwick et al. 2003)</li> <li>• S-map</li> <li>• Threatened Environment Classification (TEC)</li> <li>• Vegetation Cover Map (Newsome 1987)</li> <li>• Vulnerability to Soil Structural Degradation (Shepherd et al. 2000; Parfitt et al. 2002).</li> </ul>
	Landcare Research; Ministry for the Environment (MfE)	<ul style="list-style-type: none"> <li>• Land Environments of New Zealand (LENZ; Leathwick et al. 2002)</li> </ul>
	MfE	<ul style="list-style-type: none"> <li>• Land Use Change Analysis System (LUCAS) Land Use Map (LUM; MfE 2012)</li> </ul>
	MfE; University of Canterbury	<ul style="list-style-type: none"> <li>• Erosion Susceptibility Classification (Bloomberg et al. 2011)</li> </ul>
	New Zealand Forest Service	<ul style="list-style-type: none"> <li>• New Zealand Forest Service Forest Class Maps</li> </ul>
	University of Waikato	<ul style="list-style-type: none"> <li>• New Zealand Landscape Classification (Brabyn n.d.)</li> </ul>
<b>Freshwater</b>		
	DOC	<ul style="list-style-type: none"> <li>• Freshwater Ecosystems of New Zealand (FENZ) geodatabase (Leathwick et al. 2010b)<sup>†</sup></li> </ul>
	GNS	<ul style="list-style-type: none"> <li>• Groundwater and Geothermal Database (GGW)</li> </ul>
	LINZ	<ul style="list-style-type: none"> <li>• Geographic distribution data of surface freshwater bodies (topographic data)</li> </ul>
	MfE; National Institute of Water and Atmospheric Research (NIWA)	<ul style="list-style-type: none"> <li>• New Zealand River Environment Classification (REC; Snelder &amp; Biggs 2002; Snelder et al. 2004)</li> <li>• Various datasets relating to freshwater—e.g. water quality and monitoring data (e.g. NIWA's National Rivers Water Quality Network—NRWQN); aquifer systems and depth to groundwater; hydrometric data; state and trend of water resources</li> </ul>
	NIWA	<ul style="list-style-type: none"> <li>• Water Resources Archive</li> </ul>
	Regional councils	<ul style="list-style-type: none"> <li>• Water quality and monitoring data</li> </ul>
<b>Estuarine</b>		
	DOC; NIWA; University of Canterbury	<ul style="list-style-type: none"> <li>• Estuarine spatial definition—in preparation</li> </ul>
	LINZ	<ul style="list-style-type: none"> <li>• New Zealand mainland mangrove polygons</li> </ul>
	Landcare Research	<ul style="list-style-type: none"> <li>• Land Cover Database (LCDB; Steve Thompson &amp; Partners n.d.): mangroves and estuarine open water</li> </ul>
	NIWA	<ul style="list-style-type: none"> <li>• Estuary Environment Classification (Hume et al. 2007)</li> </ul>

Continued on next page

Table 2 continued

BIOME	ORGANISATION	DATA
<b>Marine</b>		
	DOC	<ul style="list-style-type: none"> <li>Nearshore Marine Classification and Inventory (Walls 2006)</li> </ul>
	DOC; Ministry for Primary Industries (MPI) <sup>‡</sup>	<ul style="list-style-type: none"> <li>Coastal Classification and Mapping Scheme (DOC &amp; MFish 2008, 2011)</li> </ul>
	DOC; NIWA	<ul style="list-style-type: none"> <li>Demersal Fish Community Classification (Leathwick et al. 2006b)</li> <li>Demersal Fish Optimised Marine Environment Classification (Leathwick et al. 2006a)</li> <li>Marine ecosystems of significance—in preparation (Clinton Duffy, DOC, pers. comm.)</li> <li>Predicted distribution of protected corals (Baird et al. 2013)</li> </ul>
	GNS	<ul style="list-style-type: none"> <li>Geological data (e.g. marine hydrates)</li> </ul>
	LINZ	<ul style="list-style-type: none"> <li>Hydrographic and maritime data</li> </ul>
	MPI	<ul style="list-style-type: none"> <li>Environmental marine value-mapping project (Beaumont et al. 2008)</li> </ul>
	MPI; NIWA	<ul style="list-style-type: none"> <li>Benthic Optimised Marine Environment Classification (Bowden et al. 2011; Leathwick et al. 2012b)</li> <li>Compilation of information on the spatial distribution of 13 anthropogenic threats to New Zealand marine habitats (MacDiarmid et al. 2012)</li> <li>Seamount Database (Mackay 2006)</li> </ul>
	MfE; NIWA	<ul style="list-style-type: none"> <li>Marine Environment Classification (Snelder et al. 2005)</li> </ul>
	NIWA; University of Otago	<ul style="list-style-type: none"> <li>Known and predicted distribution of habitat-forming bryozoans (Wood et al. 2013)</li> </ul>
	NIWA and other Crown Research Institutes	<ul style="list-style-type: none"> <li>Various marine and coastal geospatial data, including orbital velocity, mean significant wave height, tidal currents, high resolution bathymetry, primary productions, light at the seafloor, suspended particulate organic matter, dissolved organic matter (DOM) and a range of temperature-related metrics</li> </ul>
	See MacDiarmid et al. (2011: 10)	<ul style="list-style-type: none"> <li>Habitat area information used in the Marine Habitat Assessment Decision Support (MarHADS) Tool for mangrove forests, seagrass beds, intertidal reefs, subtidal reefs, subtidal mud, subtidal sand, subtidal gravel/pebbles/shell and seamounts,</li> </ul>

\* These Data Supplements are available for download from the DOC website (in conjunction with this report) as searchable Excel databases (<http://www.doc.govt.nz/about-us/science-publications/books-posters-and-factsheets/reports-and-books/>)

† The Wetlands of Ecological and Representative Importance (WERI) database has not been included in this table as it has been superseded by the FENZ database. However, it continues to be used as a historical snapshot of wetland distribution at the time of collection.

‡ Previously Ministry of Fisheries.

Table 3. Summary of the availability of species distribution spatial data, including names of the relevant organisations. Note: Some of the sources listed under marine and freshwater ecosystems are applicable to estuaries; and some of the sources listed under terrestrial ecosystems may be applicable to other ecosystems. See Data Supplements 1 & 2 for more detail on specific datasets\*.

BIOME	ORGANISATION	DATA
<b>Terrestrial</b>		
	Birdlife International; Forest and Bird Department of Conservation (DOC)	<ul style="list-style-type: none"> <li>Important Bird Areas (IBAs)—in preparation</li> <li>Biodiversity Data Inventory (BDI) pest animal and weed distributions (Kappers &amp; Smith 2009)</li> <li>Biodiversity Monitoring and Reporting System: tier 1 plot data</li> <li>BioWeb</li> <li>Five Minute Bird Count (5MBC) Database (Hartley 2012)</li> </ul>
	DOC; Landcare Research	<ul style="list-style-type: none"> <li>Vital Sites and Actions Model native species distributions (Overton et al. 2010)</li> </ul>
	Fairfax Media; Forest and Bird; Landcare Research; Ornithological Society of New Zealand (OSNZ)	<ul style="list-style-type: none"> <li>New Zealand Garden Bird Survey</li> </ul>
	Landcare Research	<ul style="list-style-type: none"> <li>Insect pollinator distribution maps<sup>†</sup>— note: absence only indicates where occurrence remains unrecorded</li> <li>National Vegetation Survey (NVS) Databank</li> </ul>

Continued on next page

Table 3 continued

BIOME	ORGANISATION	DATA
	New Zealand Plant Conservation Network (NZPCN)	<ul style="list-style-type: none"> <li>NZPCN Distribution Database</li> </ul>
	New Zealand Bio-Recording Network Trust	<ul style="list-style-type: none"> <li>Nature Watch species observations</li> </ul>
	New Zealand National Herbarium Network	<ul style="list-style-type: none"> <li>New Zealand Virtual Herbarium</li> </ul>
	OSNZ	<ul style="list-style-type: none"> <li>eBird species observations</li> <li>OSNZ Bird Atlas (Robertson et al. 2007)</li> </ul>
	<i>Refer to Table 2 for the spatial distribution of some flora species</i>	
<b>Freshwater</b>		
	Birdlife International; Forest and Bird DOC	<ul style="list-style-type: none"> <li>Important Bird Areas (IBAs)<sup>‡</sup>—in preparation</li> <li>BDI weed distributions (Kappers &amp; Smith 2009)</li> <li>BioWeb</li> <li>Freshwater Ecosystems of New Zealand (FENZ) geodatabase<sup>†</sup> (Leathwick et al. 2010b)</li> <li>Inanga Spawning Database<sup>†</sup> (Taylor 2002)</li> </ul>
	National Institute of Water and Atmospheric Research (NIWA)	<ul style="list-style-type: none"> <li>Native Fish Spawning Information Database<sup>‡</sup>—in preparation</li> <li>Various freshwater biodiversity data, including the New Zealand Freshwater Fish Database<sup>‡</sup>, Aquatic Plants Database and the Atlas of New Zealand Freshwater Fishes<sup>‡</sup></li> </ul>
	New Zealand Bio-Recording Network Trust	<ul style="list-style-type: none"> <li>Nature Watch species observations<sup>‡</sup></li> </ul>
	OSNZ	<ul style="list-style-type: none"> <li>eBird species observations<sup>‡</sup></li> <li>OSNZ Bird Atlas<sup>‡</sup> (Robertson et al. 2007)</li> </ul>
<b>Estuarine</b>		
	Land Information New Zealand	<ul style="list-style-type: none"> <li>New Zealand mainland mangrove polygons</li> </ul>
	<i>Refer to asterisked marine and freshwater datasets</i>	
<b>Marine</b>		
		<ul style="list-style-type: none"> <li>Species diversity associated with seamounts (Morato et al. 2010)</li> </ul>
	Birdlife International; Forest and Bird DOC	<ul style="list-style-type: none"> <li>Important Bird Areas (IBAs)<sup>‡</sup>—in preparation</li> <li>BioWeb<sup>‡</sup></li> <li>National Marine Mammal Sightings Database</li> </ul>
	DOC; NIWA	<ul style="list-style-type: none"> <li>Assessment of demersal fish richness as a surrogate for epibenthic richness (Hewitt et al. 2015)</li> <li>Modelled distributions of 72 rocky reef fish (Smith 2008; Smith et al. 2013)</li> <li>Predicted distributions of 122 demersal fishes (Leathwick et al. 2006b)</li> <li>Predicted distribution of protected corals (Baird et al. 2013)</li> </ul>
	DOC; Museum of New Zealand Te Papa Tongarewa	<ul style="list-style-type: none"> <li>New Zealand Whale Stranding Database (Brabyn 1991; Schweder-Goad 2008)</li> </ul>
	MPI	<ul style="list-style-type: none"> <li>Marine environmental value-mapping project (Beaumont et al. 2008)</li> <li>Marine mammal distributions</li> <li>Marine pest maps</li> </ul>
	MPI; NIWA	<ul style="list-style-type: none"> <li>Marine fisheries and biodiversity data<sup>‡</sup></li> <li>National Aquatic Biodiversity Information System (NABIS)<sup>‡</sup></li> <li>Predicted distributions of selected benthic invertebrates (Bowden et al. 2011; Leathwick et al. 2012b)</li> </ul>
	NIWA; University of Otago	<ul style="list-style-type: none"> <li>Known and predicted distributions of habitat-forming bryozoans (Wood et al. 2013)</li> </ul>
	New Zealand Bio-Recording Network Trust	<ul style="list-style-type: none"> <li>Nature Watch species observations<sup>‡</sup></li> </ul>
	OSNZ	<ul style="list-style-type: none"> <li>eBird species observations<sup>‡</sup></li> <li>OSNZ Bird Atlas<sup>‡</sup> (Robertson et al. 2007)</li> </ul>

\* These Data Supplements are available for download from the DOC website (in conjunction with this report) as searchable Excel databases (<http://www.doc.govt.nz/about-us/science-publications/books-posters-and-factsheets/reports-and-books/>)

† Maps based on several major insect collections—Auckland War Memorial Museum, Canterbury Museum, Lincoln University Entomology Research Museum, Museum of New Zealand Te Papa Tongarewa, New Zealand Arthropod Collection (Landcare Research) and Otago Museum.

‡ Also apply to estuaries.



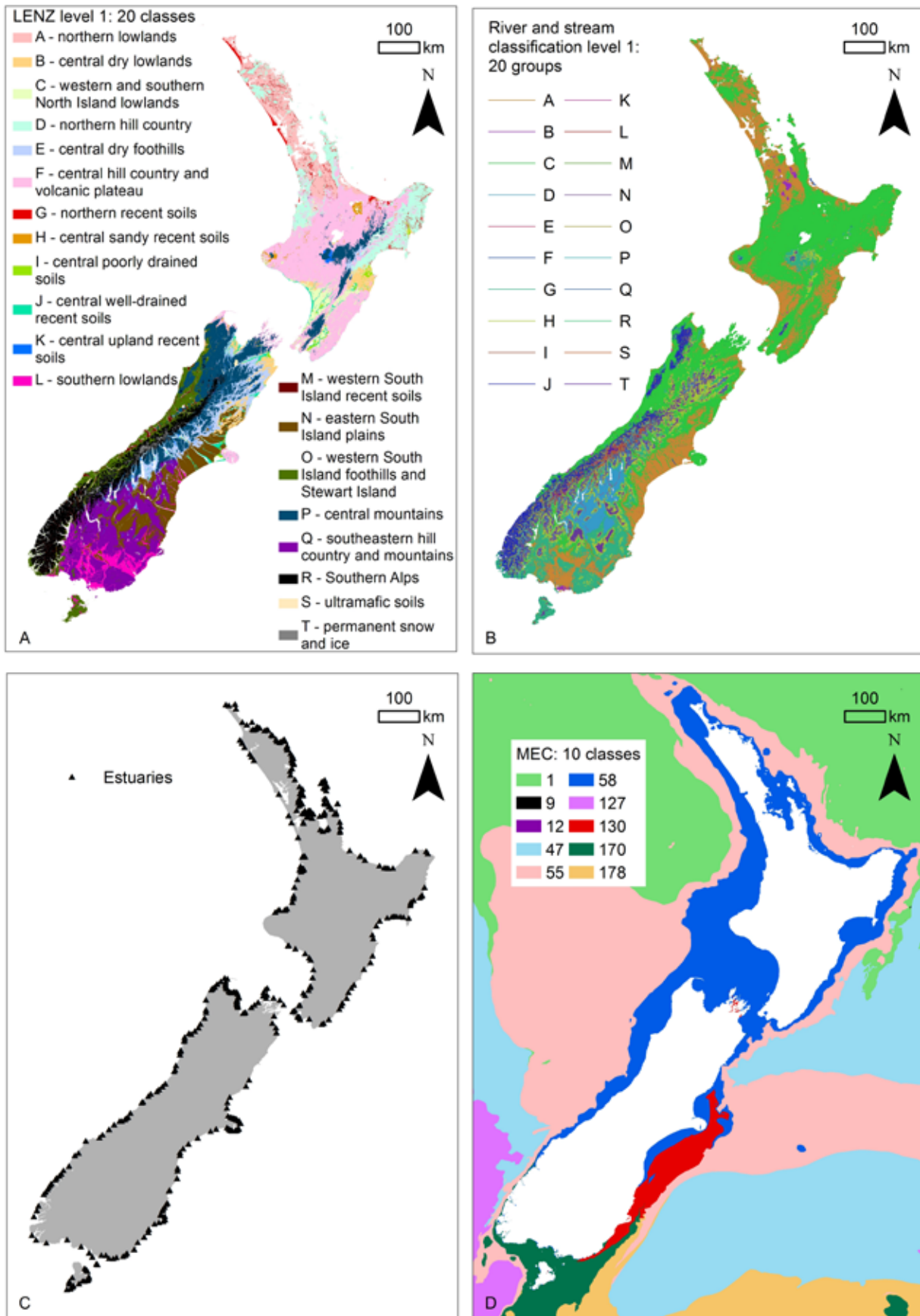

Figure 3. Examples of spatial data for each of the four biomes: A. Terrestrial—Land Environments of New Zealand (LENZ), an ecological classification system based on various climate, landform and soil variables of relevance to biological distributions, mapped using 20 classes (Leathwick et al. 2002); B. Freshwater—Freshwater Environments of New Zealand Version 1 (FENZv1) River and Stream Classification, which groups together river segments with similar environmental conditions regardless of their geographical location, mapped using 20 groups (Leathwick et al. 2010b); C. Estuaries—location of known estuaries in New Zealand according to the Estuary Environment Classification (Hume et al. 2007), NIWA; and D. Marine—the Marine Environment Classification, based on several spatially explicit physical environmental data layers, mapped using 10 classes (see Snelder et al. (2005) for class descriptions).

- Costanza et al. (2006) and Liu et al. (2010) estimated the economic values of ecosystem services in New Jersey by ‘transferring’ economic estimates from studies conducted elsewhere, based on ecosystem type, linking these values to available **land cover data**, and then aggregating them according to spatial boundary data such as watersheds (Liu et al. 2010). Similarly, Petter et al. (2012) used **biophysical data** layers to map ecosystem functions that underpin ecosystem service provision.
- The **distributions of iconic species** can be used to represent areas that are high value for cultural ecosystem services, such as identity values (see section 6.1.2).
- **Biophysical and land use data** are commonly required as data inputs by GIS-based ecosystem service assessment tools and models (see Appendix 1).

#### 4.1.1 Terrestrial ecosystems

Species distributions, pressure data and other ecological data can be sourced from DOC’s Vital Sites and Actions Project (Overton et al. 2010) in the form of spatial grids with national coverage. The distributions of pest and weed species have also been mapped for DOC’s Biodiversity Data Inventory (Kappers & Smith 2009), and have subsequently been used in the Vital Sites and Actions Project. In addition, the Biodiversity Monitoring and Reporting System<sup>13</sup>, which was developed by DOC in association with Landcare Research, also collects national-level information on the status and trend of indigenous species, ecosystems and pests.

Other potential sources of species occurrence or distribution data include the National Vegetation Survey (NVS) Databank<sup>14</sup>, the New Zealand Plant Conservation Network Distribution Database<sup>15</sup>, New Zealand Virtual Herbarium (New Zealand National Herbarium Network)<sup>16</sup>, the Ornithological Society of New Zealand (OSNZ) Bird Atlas (Robertson et al. 2007), the New Zealand Garden Bird Survey (Fairfax Media, Forest and Bird, Landcare Research, OSNZ)<sup>17</sup>, the Five Minute Bird Count Database (DOC; Hartley 2012), the Important Bird Area (IBA) Programme by Birdlife International and Forest and Bird (in preparation), Nature Watch<sup>18</sup>, BioWeb (DOC), and museum collections (e.g. insect pollinator distribution maps<sup>19</sup> based on records from six major insect collections in New Zealand—Auckland War Memorial Museum, Canterbury Museum, Lincoln University Entomology Research Museum, Museum of New Zealand Te Papa Tongarewa, New Zealand Arthropod Collection (Landcare Research) and Otago Museum).

There are also several GIS-enabled databases that describe and/or classify ecosystem type, land cover, land use and other environmental characteristics, such as the Land Cover Database (LCDB; Steve Thompson & Partners n.d.), the Land Environments of New Zealand (LENZ; Leathwick et al. 2002; see Fig. 3A), the Land Use and Carbon Analysis System (LUCAS) Land Use Map (LUM; MfE 2012), AgriBase (AsureQuality), Ecosat Basic Land Cover (Landcare Research), the Generalised Dissimilarity Modelling Terrestrial Ecosystem Classification (Overton et al. n.d.), the Erosion Susceptibility Classification (Ministry for the Environment—MfE, University of Canterbury; Bloomberg et al. 2011), the New Zealand Land Resource Inventory (Landcare Research), the Fundamental Soil Layer (Landcare Research), Vulnerability to Soil Structural Degradation (Shepherd et al. 2000; Parfitt et al. 2002), QMap (Institute of Geological and

<sup>13</sup> [www.doc.govt.nz/about-us/our-role/managing-conservation/natural-heritage-management/a-national-system-to-monitor-and-report-on-biodiversity](http://www.doc.govt.nz/about-us/our-role/managing-conservation/natural-heritage-management/a-national-system-to-monitor-and-report-on-biodiversity) (accessed 20 April 2015).

<sup>14</sup> <https://nvs.landcareresearch.co.nz> (accessed 19 March 2015).

<sup>15</sup> [www.nzpcn.org.nz/page.aspx?flora\\_distribution](http://www.nzpcn.org.nz/page.aspx?flora_distribution) (accessed 19 March 2015).

<sup>16</sup> [www.virtualherbarium.org.nz](http://www.virtualherbarium.org.nz) (accessed 20 April 2015).

<sup>17</sup> [www.forestandbird.org.nz/node/107858](http://www.forestandbird.org.nz/node/107858) and [www.landcareresearch.co.nz/science/plants-animals-fungi/animals/birds/garden-bird-surveys](http://www.landcareresearch.co.nz/science/plants-animals-fungi/animals/birds/garden-bird-surveys) (accessed 20 April 2014).

<sup>18</sup> <http://naturewatch.org.nz> (accessed 19 March 2015).

<sup>19</sup> [www.landcareresearch.co.nz/science/plants-animals-fungi/plants/pollination/pollinator-profiles](http://www.landcareresearch.co.nz/science/plants-animals-fungi/plants/pollination/pollinator-profiles) (accessed 20 April 2015).

Nuclear Sciences—GNS)<sup>20</sup>, and the Topographic Database (LINZ). Other databases describing vegetation cover include Ecosat Forests (Landcare Research), Ecosat Woody (Landcare Research; Dymond & Shepherd 2004), New Zealand Forest Service Forest Class Maps, Potential Vegetation of New Zealand (Landcare Research; Leathwick et al. 2003) and the Vegetation Cover Map (Newsome 1987). DOC is also currently undertaking a project to map ecosystems that are considered to be historically rare, as defined by Williams et al. (2007), by combining digital environmental data, satellite imagery and expert knowledge (Singers & Rogers 2014). Furthermore, Lars Brabyn (University of Waikato) developed the New Zealand Landscape Classification (Brabyn n.d.) based on biophysical, human and experiential characteristics. This classification is also applicable to freshwater, estuarine and marine environments, as water and water views (which could be interpreted as a transfer of values from aquatic to terrestrial environments) are included in its classification.

DOC's Ecosystem Optimisation Project (Leathwick & Wright 2011; Leathwick et al. 2012a) also resulted in the development of other ecological and management-related data to enable the prioritisation of DOC's ecosystem management units (EMUs) according to criteria such as ecosystem type representation, distinctive geological substrates, threatened species distributions, pressures and management of pressures, expected losses and gains in ecological integrity for terrestrial ecosystems if any management ceases or commences, and costs. However, the spatial extent of the data resulting from this project was limited to that of DOC's EMUs and so, although national in scope, it has only partial coverage. Another limitation has been the lack of comprehensive maps of New Zealand's terrestrial ecosystem pattern (Leathwick et al. 2012a). In the absence of such mapping, Singers & Rogers (2014) developed a terrestrial ecosystem classification to aid prioritisation (Leathwick et al. 2012a). Unfortunately, this system is not spatially explicit, but despite this several regional councils have work underway to map their regions according to it (Amy Hawcroft, DOC, pers. comm.).

#### 4.1.2 Freshwater ecosystems

Databases describing the geographic distributions and/or characteristics of freshwater environments and species include the River Environment Classification (MfE; National Institute of Water and Atmospheric Research—NIWA; Snelder & Biggs 2002; Snelder et al. 2004), the Inanga Spawning Database (DOC; Taylor 2002), the Freshwater Ecosystems of New Zealand (FENZ) geodatabase (DOC; Leathwick et al. 2010b; see Fig. 3B), the Groundwater and Geothermal Database (GNS), water quality and monitoring data from regional councils, and other freshwater datasets from NIWA, such as the New Zealand Freshwater Fish Database<sup>21</sup> and National Rivers Water Quality Network<sup>22</sup>. In addition, some of the datasets listed for terrestrial ecosystems (see section 4.1.1) are also relevant to freshwater ecosystems (e.g. topographic data from LINZ<sup>23</sup> and Robertson et al.'s (2007) OSNZ Bird Atlas).

The Inanga Spawning Database (Taylor 2002) is a collection of spawning location records for inanga (*Galaxias maculatus*), but unfortunately it has not been consistently maintained. Consequently, NIWA is currently leading the development of a new Native Fish Spawning Information Database<sup>24</sup>. The FENZ geodatabase provides the most current national-level summary of environmental, biological and pressure information for New Zealand's rivers, lakes

---

<sup>20</sup> [www.gns.cri.nz/Home/Our-Science/Earth-Science/Regional-Geology/Geological-Maps/1-250-000-Geological-Map-of-New-Zealand-QMAP/QMAP-text-maps](http://www.gns.cri.nz/Home/Our-Science/Earth-Science/Regional-Geology/Geological-Maps/1-250-000-Geological-Map-of-New-Zealand-QMAP/QMAP-text-maps) (accessed 20 April 2015).

<sup>21</sup> [www.niwa.co.nz/our-services/online-services/freshwater-fish-database](http://www.niwa.co.nz/our-services/online-services/freshwater-fish-database) (accessed 20 April 2015).

<sup>22</sup> [www.niwa.co.nz/freshwater/water-quality-monitoring-and-advice/national-river-water-quality-network-nrwqn](http://www.niwa.co.nz/freshwater/water-quality-monitoring-and-advice/national-river-water-quality-network-nrwqn) (accessed 19 March 2015).

<sup>23</sup> [www.linz.govt.nz/data/linz-data/topographic-data](http://www.linz.govt.nz/data/linz-data/topographic-data) (accessed 19 March 2015).

<sup>24</sup> <https://teamwork.niwa.co.nz/display/NZFWSPAWN/Native+Fish+Spawning+Information> (accessed 19 March 2015).

and wetlands<sup>25</sup>. It includes condition scores that are based on pressures and their predicted impacts<sup>26</sup>; and given that condition is directly linked to ecosystem function for some ecosystem services (McLaughlin & Cohen 2013), these scores could potentially be used as a proxy for the effectiveness of ecosystem service delivery for a particular water body relative to its pristine state. FENZ also includes regional and national priority rankings, which were calculated using the spatial conservation prioritisation software Zonation (Leathwick et al. 2010b), and data on biological distribution, environmental parameters, human pressure estimates and connectivity (Leathwick et al. 2010a).

#### 4.1.3 Estuarine ecosystems

Hume et al. (2007) developed a classification of estuarine environments, which is currently being refined through a collaboration between NIWA, DOC and the University of Canterbury. Location data for estuaries is available from NIWA (see Fig. 3C), along with their hydrodynamic class based on Hume et al.'s (2007) classification. In addition, polygons for mangroves are available from LINZ and the LCDB, and for estuarine open waters from the LCDB. Species occurrence and distribution data are also available from several databases, including the Inanga Spawning Database, the Native Fish Spawning Information Database and the OSNZ Bird Atlas.

DOC is currently undertaking an information review of estuaries, which includes a stocktake of broad-scale habitat maps of estuaries and information on the ecosystem services they provide. Regional councils are the main holders of spatial habitat data (e.g. seagrass, mangroves, saltmarsh) and these are currently being combined into national data layers (including temporal data) with assistance from DOC (Helen Kettles, DOC, pers. comm.).

In addition, the United Nations Environment Programme World Conservation Monitoring Centre (UNEP-WCMC) recently invited contributions to their Global Saltmarsh Atlas, which follows the creation of the first global atlases for coral, mangroves, seagrasses and other marine habitat data<sup>27, 28</sup>.

#### 4.1.4 Marine ecosystems

Several spatially explicit classifications of marine environments in New Zealand have been developed (see MacDiarmid et al. (2013) for a good overview). The first of these classifications was the New Zealand Marine Environment Classification (MEC; Snelder et al. 2005), which was based on physical variables that explained the most biological variation (see Fig. 3D). The MEC is hierarchical, meaning that users are able to define environmental variables at different levels of detail and a range of associated spatial scales (MacDiarmid et al. 2013). However, subsequent evaluation revealed that it was not necessarily a good surrogate for biological patterns (e.g. Smith 2006). In response, the Demersal Fish Community Classification (Leathwick et al. 2006b), the Demersal Fish Optimised Marine Environment Classification (Leathwick et al. 2006a) and the Benthic Optimised Marine Environment Classification (BOMECE; Leathwick et al. 2012b) were developed. Testing revealed that the Demersal Fish Community Classification was a superior predictor of biological patterns than the Demersal Fish Optimised Marine Environment Classification (Clinton Duffy, DOC, pers. comm.), and that the BOMECE was an improvement over the MEC for mapping benthic invertebrate distributions at larger scales (Bowden et al. 2011). In addition, the Coastal Biogeographic Regions Classification (DOC & MFish 2008, 2011) was developed by DOC and the Ministry of Fisheries (now Ministry for Primary Industries—

---

<sup>25</sup> There are plans to update the FENZ wetlands layer regularly (i.e. every 10 years; Philippe Gerbeaux, DOC, pers. comm.).

<sup>26</sup> Predicted impacts were derived from expert-driven curves that were used to transform pressure indicators into an ecological integrity index—for example, see Ausseil et al. (2008, 2011a) for wetlands.

<sup>27</sup> Hutton, J. n. d.: An invitation to contribute to the Global Saltmarsh Atlas and to moderate its content through the online data validation tool. Letter from the Director of UNEP-WCMC to potential contributors.

<sup>28</sup> [http://thebluecarboninitiative.org/wp-content/uploads/UNEP-WCMC-Global-Saltmarsh-Layer\\_pdf\\_version.pdf](http://thebluecarboninitiative.org/wp-content/uploads/UNEP-WCMC-Global-Saltmarsh-Layer_pdf_version.pdf) (accessed 4 April 2014).

MPI) to classify and map coastal habitats to an extent of 12 nautical miles based on physical environmental characteristics. Today, the Ministry for the Environment uses this classification, the Demersal Fish Community Classification and the Marine Environment Classification to report on the national state of the marine environment<sup>29</sup>.

The spatial distributions of several marine species have been modelled, including rocky reef fish (Smith 2008; Smith et al. 2013), protected corals (Baird et al. 2013), demersal fishes (Leathwick et al. 2006b), benthic invertebrates (Leathwick et al. 2012b; Bowden et al. 2011) and habitat-forming bryozoans (Wood et al. 2013). Spatial data relating to the occurrence of marine species are also available from various databases, such as the National Marine Mammal Sightings Database<sup>30</sup> (DOC), the New Zealand Whale Stranding Database (Brabyn 1991; Schweder-Goad 2008) and the National Aquatic Biodiversity Information System (NABIS; MPI, NIWA)<sup>31</sup>. MPI also owns several fisheries datasets relating to both commercial and recreational fishing (including for non-fish and protected species bycatch—e.g. Abraham & Thompson 2011, 2012; Thompson et al. 2013), and other marine biodiversity and environmental data. In addition, data relating to marine ecosystems are available from LINZ, and CRIs such as GNS and NIWA, and some of the datasets listed for terrestrial ecosystems (see section 4.1.1) are also relevant to marine ecosystems (e.g. Robertson et al.'s (2007) OSNZ Bird Atlas and the IBA Programme).

Other work of interest includes the assessment of the use of demersal fish diversity as a surrogate for epibenthic richness (Hewitt et al. 2015), which was carried out by NIWA on behalf of DOC (Clinton Duffy, DOC, pers. comm.); the identification of significant marine ecosystems in the New Zealand Territorial Sea and Exclusive Economic Zone (EEZ) using Zonation, which is currently underway (Clinton Duffy, DOC, pers. comm.); MacDiarmid et al.'s (2012) compilation of information relating to the spatial distribution of 13 anthropogenic threats to marine habitats; MPI's environmental marine value-mapping project (Beaumont et al. 2008; see section 4.4.2); and Morato et al.'s (2010) work on species diversity at seamounts. The latter is of particular interest to ecosystem services, as seamounts are often hotspots of biological activity and diversity, and play an important role in marine food webs (Simard & Spadone 2012), supporting the generation of marine ecosystem services. Furthermore, they are also often areas of significant commercial importance<sup>32</sup>. For example, seamounts and other features such as submarine canyons or frontal systems are important for migratory species, such as marine mammals, marine turtles and seabirds (Taranto et al. 2012), which are often targeted by commercial and recreational wildlife watchers and nature-based tourists. Seamounts also help to support fisheries. For example, deep-sea fisheries target several fish species that are specifically associated with seamounts (Rogers 2012), with at least 2 million tonnes of deep-sea species being trawled from seamounts since the late 1960s (Clark et al. 2010). Today, major seamount fisheries include alfonsino (*Beryx splendens*), pelagic (slender) armorhead (*Pseudopentaceros wheeleri*), black cardinalfish (*Epigonus telescopus*), orange roughy (*Hoplostethus atlanticus*), roundnose grenadier (*Coryphaenoides rupestris*), oreos (smooth oreo *Pseudocyttus maculatus*, black oreo *Allocyttus niger*) and toothfish (*Dissostichus eleginoides*, *D. antarcticus*) (Clark et al. 2010). It should be noted that seamount ecology is not yet fully understood, however (see Clark et al. 2010).

#### 4.1.5 Discussion

The major sources and custodians of ecological and biodiversity data are CRIs, government departments and regional councils. However, some non-government organisations (e.g. OSNZ) also hold nationally important datasets.

---

<sup>29</sup> [www.mfe.govt.nz/more/environmental-reporting/about-environmental-reporting-nz/classification-systems-environmental-3](http://www.mfe.govt.nz/more/environmental-reporting/about-environmental-reporting-nz/classification-systems-environmental-3) (accessed 21 April 2015).

<sup>30</sup> [www.doc.govt.nz/marinemammalsightings](http://www.doc.govt.nz/marinemammalsightings) (accessed 19 March 2015).

<sup>31</sup> [www.nabis.govt.nz](http://www.nabis.govt.nz) (accessed 19 March 2015).

<sup>32</sup> [www.iucn.org/about/work/programmes/marine/marine\\_our\\_work/marine\\_governance/seamounts](http://www.iucn.org/about/work/programmes/marine/marine_our_work/marine_governance/seamounts) (accessed 28 June 2013).

Ecological and biodiversity data were most readily available for terrestrial ecosystems, for which there are national databases representing soil characteristics, topography, land cover, land use, vegetation characteristics and some species distributions. This may at least in part be attributed to the ability to capture ecological data from satellite imagery in terrestrial environments. It should be noted though that the resolution and accuracy of some of these datasets is limited—a particularly important consideration in local-scale assessments and analyses. Further, the need for comprehensive mapping of New Zealand’s terrestrial ecosystem patterns has still not been addressed, despite the value of doing so being identified more than 30 years ago (Leathwick et al. 2012a).

Several national datasets were also identified for freshwater ecosystems, with the FENZ geodatabase providing the most current national-level summary of environmental, biological and pressure information for New Zealand’s rivers, lakes and wetlands. This geodatabase is based on a combination of measured data, modelled data and expert opinion, and so contains some uncertainties and inaccuracies (see Leathwick et al. 2010b). It should also be noted though that spatially defining freshwater systems is challenging, as some can be too small to be identified using common satellite resolution and their spatial extents can vary seasonally (e.g. see Ausseil et al. 2011b for wetlands).

Estuaries are still not adequately covered by current land classifications (Williams et al. 2007), although this is currently being addressed by several initiatives (see section 4.1.3). It is particularly important that this gap is addressed, because estuaries provide a disproportionately large number of ecosystem services for their size relative to other ecosystems (Costanza et al. 1997). These include services such as nursery grounds for fishery species, storm surge protection and recreation. Furthermore, they are considered to be a historically rare (Williams et al. 2007) or naturally uncommon (Holdaway et al. 2012) ecosystem type, and continue to be under threat from anthropogenic modification and climate change. Therefore, the development of spatial data for estuaries is likely to better equip researchers and analysts to map the ecosystem services provided by estuaries at national, regional and local levels, which will enable more effective communication of the importance of estuaries to the wellbeing of local communities. This is particularly important in New Zealand, where the conservation and restoration of estuaries depend on stakeholders external to DOC, as most estuarine systems and their margins are not located in public conservation lands and waters.

The extent and quality of available biological and environmental information was most variable for marine ecosystems. Indeed, much of the marine environment and its diverse communities remain poorly charted (MacDiarmid et al. 2013), largely due to the vastness of New Zealand’s Territorial Sea and EEZ<sup>33</sup>, and the high cost of marine surveys. Intertidal, mid-shelf and upper slope (c. 50–2000 m depth) habitats and species distributions are the best known. By contrast, large areas of the inner shelf<sup>34</sup> have never been mapped due to high levels of turbidity and habitat heterogeneity, constrained navigation, and greatly reduced efficiency of acoustic survey tools (side-scan and multibeam sonar) in shallow water. Very little sampling or research has also been conducted below 2500 m depth within the EEZ, and so large-scale ecosystem and species distributions are often inferred from oceanographic information and data collected during commercial operations (e.g. fishing, mineral exploration and prospecting). The use of satellite imagery is limited to data derived from ocean colour (chlorophyll a, dissolved organic matter, suspended particulate matter), infrared (temperature) and radar (sea surface elevation/ocean currents). Information derived from underwater remote sensing (e.g. side-scan sonar, multibeam

---

<sup>33</sup> New Zealand’s Territorial Sea extends from the shore out to 12 nautical miles; whereas the Exclusive Economic Zone starts from 12 nautical miles from the shore and extends to 200 nautical miles from the shore (see [www.doc.govt.nz/nature/habitats/marine/new-zealands-marine-environment](http://www.doc.govt.nz/nature/habitats/marine/new-zealands-marine-environment); accessed 20 March 2015).

<sup>34</sup> The inner shelf is likely to vary across New Zealand, but typically extends from the surf zone to around 50–100 m depth (Shane Geange, DOC, pers. comm.). It is usually defined in terms of upwelling dynamics, being the region of reduced cross-shelf transport that is inshore of the upwelling front (Shane Geange, DOC, pers. comm.).

backscatter analysis) can be used to infer benthic habitat distributions, but most of this is collected by commercial operations and is not readily available. Although swath mapping, using a multi-beam acoustic system, offers an opportunity to define wide areas of seafloor habitat, only a small portion of New Zealand's marine habitats have been surveyed using this technique to a standard necessary to map benthic habitats (MacDiarmid et al. 2013)—at current rates, it will take another 50 years to swath map New Zealand's Territorial Sea, EEZ and the extended continental shelf (MacDiarmid et al. 2013). Despite these constraints, several national-scale marine environment classifications have been developed for marine management purposes<sup>35</sup> and many species distributions have also been modelled. Nevertheless, it is important to recognise that most mapping to date has been at a coarse scale and based on modelled data (with associated uncertainty) or only on physical habitat types, and so ecosystem service mapping is likely to remain challenging until this general lack of high-resolution biophysical habitat spatial data has been addressed.

## 4.2 Historic heritage data

Historic heritage spatial data can be obtained from five main sources:

- ArchSite<sup>36</sup>—This is the website for the New Zealand Archaeological Association's (NZAA's) Archaeological Site Recording Scheme. This project, which aims to make archaeological information available online, has been undertaken by the NZAA in partnership with Heritage New Zealand (formerly the New Zealand Historic Places Trust) and DOC, and with initial funding from the Department of Internal Affairs' Community Partnership Fund.
- DOC's Asset Management and Information System (AMIS)—This contains the locations of historic places that are managed by DOC, including actively conserved historic places.
- The New Zealand Heritage List<sup>37</sup> (formerly the National Register of Historic Places)—This records information, including location data, about New Zealand's significant and valued historic and cultural heritage places. The register includes historic places (e.g. bridges, memorials, pā (fortified sites), archaeological sites, mining sites, whaling stations, shipwrecks), historic areas (e.g. cultural landscapes<sup>38</sup>, groups of related historic places), wāhi tapu (places that are considered sacred to Māori) and wāhi tapu areas (groups of wāhi tapu). Historic places are divided into two categories: places of 'special or outstanding historical or cultural heritage significance or value' (Category I); and places of 'historical or cultural heritage significance' (Category II). Significance may relate to aesthetic, archaeological, architectural, cultural, historical, scientific, social, spiritual, technological or traditional values.
- LINZ's<sup>39</sup> topographic data—This includes location data for monument, historic and pā sites.
- The Ministry for Culture and Heritage<sup>40</sup>—This government department has information (including location data) about memorials, historic graves and monuments.

Although there are spatial data for historically significant locations within public conservation areas, there is scope for improving their spatial definitions. To date, DOC's management of information relating to these sites has mainly focused on their physical attributes (i.e. preserved

---

<sup>35</sup> MfE uses the Marine Environment Classification, the Demersal Fish Community Classification and the Coastal Biogeographic Regions Classification to monitor the state of the marine environment—see [www.mfe.govt.nz/environmental-reporting/about-environmental-reporting/classification-systems/marine.html](http://www.mfe.govt.nz/environmental-reporting/about-environmental-reporting/classification-systems/marine.html) (accessed 10 September 2014).

<sup>36</sup> [www.archsite.org.nz](http://www.archsite.org.nz) (accessed 28 May 2014).

<sup>37</sup> [www.heritage.org.nz/the-list](http://www.heritage.org.nz/the-list) (accessed 28 May 2014).

<sup>38</sup> For a definition, see section 6.2.1.

<sup>39</sup> [www.linz.govt.nz](http://www.linz.govt.nz) (accessed 11 September 2013).

<sup>40</sup> [www.mch.govt.nz](http://www.mch.govt.nz); [www.nzhistory.net.nz/culture/about-the-memorials-register](http://www.nzhistory.net.nz/culture/about-the-memorials-register) and [www.nzhistory.net.nz/map/new-zealand-wars-memorial-map#map](http://www.nzhistory.net.nz/map/new-zealand-wars-memorial-map#map) (accessed 11 September 2013).

fabric). In the future, DOC plans to develop physical, historical, cultural and visitor typologies as part of its historic optimisation project in recognition of the wider values associated with historic sites (Egerton n.d.). This is likely to be useful for mapping historic heritage services. Moreover, there is an opportunity to make these typologies compatible with an ecosystem services framework/typology, which would contribute towards integrating assessments of both types of services, leading to better informed and more transparent decision-making. This is particularly useful for dual-purpose agencies such as DOC, who are responsible for the conservation of both historic and natural heritage.

### 4.3 Human activities and built infrastructure data

We identified several spatial datasets that relate to areas where humans derive benefits from indigenous species and ecosystems and historic heritage (see Data Supplements 1 & 2). DOC's Asset Management and Information System (AMIS) and Permissions Database contain data relating to human activities and built infrastructure in public conservation areas; and LINZ holds a large amount of data relating to built infrastructure across the whole of New Zealand, which could be used to develop indicators for human activities. Other examples of national human activities and built infrastructure datasets include the National Environmental Standard Drinking Water Sources and Treatment Plants Database (Ministry of Health), data held by Statistics New Zealand, the Recreation Opportunity Spectrum (Joyce & Sutton 2009), regional council data (e.g. resource consents), fisheries data held by MPI, mineral and petroleum permit data held by the Ministry of Economic Development (MED), and the National Apiary Database (National American Foul Brood Pest Management Agency). In addition, a few key research initiatives have resulted in the development of databases containing human use data (see section 4.4).

Four examples of these data sources are discussed in more detail below to illustrate the limitations that are often associated with data sources relating to human activities and built infrastructure.

#### 4.3.1 Asset Management Information System (AMIS)

AMIS is DOC's integrated financial and asset management system. It is linked to NATIS 1, which houses the spatial data component of AMIS. AMIS contains information about the natural, historic heritage and visitor assets and infrastructure managed by DOC, including information about the environmental attributes of sites, historic heritage, visitor use and activities, visitor facilities and amenities, accessibility, and other information of relevance to management. We explored the relevance of these data to ecosystem services and summarised this in Table 4. At the time, information was stored in a five-tiered system, with its smallest units being 'equipment', several of which make up a functional location (see Fig. 4). Since then, some changes have been made to the system, including the adoption of a more flexible information structure that is no longer bound by DOC's management structure (Michaela Smith, DOC, pers. comm.).

Unfortunately, the information within AMIS has not been consistently maintained, with some not having been updated since DOC moved across to AMIS from its old information management system (VAMS) in June 2008. Equipment-level information is better maintained than functional location level information because it helps to ensure that service standards are met, which is a priority for operational staff. The fact that functional location level information is not reliably and consistently maintained is unfortunate, as some of the attribute information stored at the functional location level is of relevance to the services and benefits provided by the natural and historic heritage administered by DOC (see Table 4).

If AMIS is updated and maintained in the future, visitor attribute information and significance scores for natural, historic heritage, scenic and recreational values could be used to identify where these values spatially coincide and how well management priorities protect areas of



Table 4. Summary of attribute information stored within the recording capacity of the Department of Conservation's (DOC's) Asset Management and Information System (AMIS) at the 'functional location' and 'equipment' levels. Note: This structure reflects AMIS in 2013.

ATTRIBUTE TYPE	ATTRIBUTE FIELD EXAMPLE(S)
<b>Functional location</b>	
Access	<ul style="list-style-type: none"> <li>• Grid reference (E, N)</li> </ul>
Hazard assessment	<ul style="list-style-type: none"> <li>• Flooding, volcano, avalanche</li> </ul>
Site activities*	<ul style="list-style-type: none"> <li>• Mountain biking (actual/potential; condition/grade)</li> </ul>
Management*	<ul style="list-style-type: none"> <li>• Class (e.g. visitor or historic site)</li> <li>• Historic icon</li> <li>• Actively conserved historic place</li> <li>• Visitor group and preferred visitor group (short stop travellers (SST), day visitors (DV), overnights (ON), backcountry comfort seekers (BCC), backcountry adventurers (BCA), remoteness seekers (RS), thrill seekers (TS), biodiversity, historic) (DOC 1996)</li> <li>• Recreational Opportunity Spectrum (ROS) class (wilderness, 4x4 drive in, backcountry drive in, backcountry walk in, remote, rural, urban, urban fringe)</li> <li>• Track classification (path, short walk, great walk tramping track, easy tramping track, classic tramping track, route) (Standards New Zealand 2004)</li> </ul>
Site priority*	<ul style="list-style-type: none"> <li>• Historic site type (e.g. maritime transport)</li> <li>• Historic theme (e.g. mining, high country farming)</li> <li>• Significant historic value (high/medium/low)</li> <li>• Significant human history (Y/N)</li> <li>• Significant natural value (high/medium/low)</li> <li>• Significant natural features (Y/N)</li> <li>• Significant scenic value (high/medium/low)</li> <li>• Visitor monitoring location (Y/N)</li> <li>• Visitors counted (Y/N)</li> <li>• Visitor number trend (% increase/decrease)</li> <li>• Visitor numbers (BCA, BCC, DV, ON, RS, SST, total)</li> <li>• Visitor site priority scores (DOC n.d.): <ul style="list-style-type: none"> <li>– Visitor numbers (1–10)</li> <li>– Future visitor numbers (1–10)</li> <li>– Recreational/educational importance (1–10)</li> <li>– Conservation appreciation (1–10)</li> <li>– Overall (total = 1–40)</li> </ul> </li> </ul>
<b>Equipment</b>	
Cooking/heating*	<ul style="list-style-type: none"> <li>• Cookers/heating provided for visitors</li> </ul>
Equipment*	<ul style="list-style-type: none"> <li>• Track formation</li> <li>• Type of archaeological site, historic track, visitor accommodation, etc.</li> </ul>
Historic Heritage Assessment*	<ul style="list-style-type: none"> <li>• Historic Heritage Assessment (Y/N); completion date</li> </ul>
Historic management*	<ul style="list-style-type: none"> <li>• New Zealand Archaeological Association (NZAA) number</li> <li>• Heritage New Zealand (formerly Historic Places Trust) Category (Category I = 'special outstanding historical/cultural significance/value'; or Category II = 'historical/cultural significance/value')</li> </ul>
Management*	<ul style="list-style-type: none"> <li>• Visitor group, warden on site, hut is on a day tramping track</li> </ul>
Measurement point characteristics*	<ul style="list-style-type: none"> <li>• No. youth/adult bed-nights, visitor count</li> </ul>
Ongoing Inspection (OGI) results*	<ul style="list-style-type: none"> <li>• Impact vegetation tramping, visitor impacts acceptable</li> </ul>
Visitor impacts/information*	<ul style="list-style-type: none"> <li>• Estimated bed-nights</li> </ul>
Water/waste management*	<ul style="list-style-type: none"> <li>• Toilets provided, distance to water body from hut, water supply</li> </ul>

Continued on next page

Table 4 continued

ATTRIBUTE TYPE	ATTRIBUTE FIELD EXAMPLE(S)
Access for DOC staff	<ul style="list-style-type: none"> <li>• Quadbike</li> </ul>
Component condition results	<ul style="list-style-type: none"> <li>• Electrical/light condition</li> </ul>
Engineer	<ul style="list-style-type: none"> <li>• Vehicle bridge load capacity</li> </ul>
Equipment life	<ul style="list-style-type: none"> <li>• Estimated built period</li> </ul>
Fire safety	<ul style="list-style-type: none"> <li>• No. fire extinguishers</li> </ul>
Hazard assessment	<ul style="list-style-type: none"> <li>• Flooding/debris flow</li> </ul>
Historic component condition results	<ul style="list-style-type: none"> <li>• Rock art visibility</li> </ul>
Service Standard (SS) general maintenance/update in office	<ul style="list-style-type: none"> <li>• Provision of cookers meet standard</li> </ul>

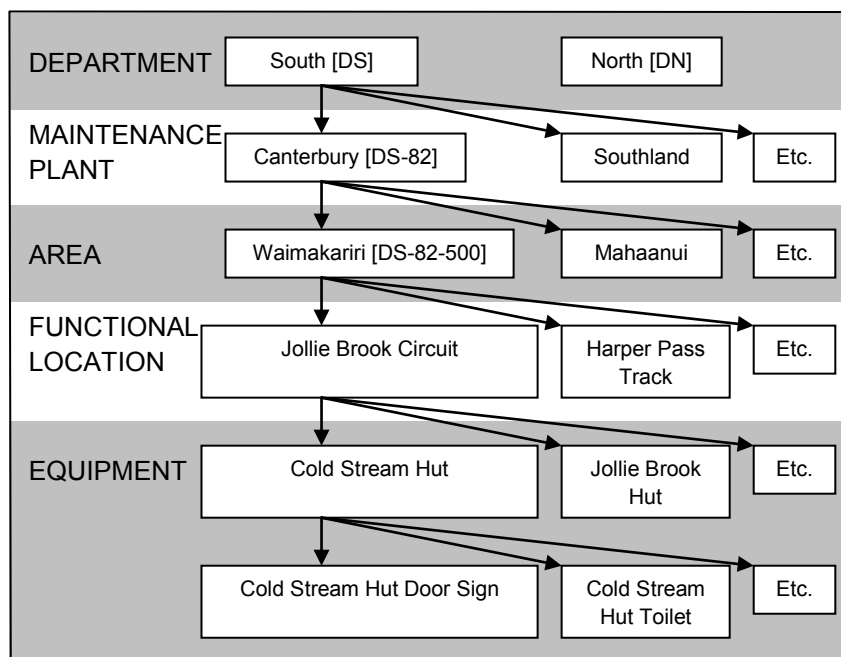

Figure 4. The five-tier information structure of the Department of Conservation's Asset Management Information System (AMIS), including examples and codes. Note: This diagram reflects AMIS in 2013.

highest overall value. Visitor numbers and visitor asset attribute information could also be used to quantify and predict visitor use (see section 6.1.1); and the historic typology attribute information (e.g. historic theme) could be used to map historic values (see section 6.2.2). AMIS also offers the flexibility for other attribute fields to be added if further information of relevance to such work needed to be collected. Nevertheless, it should be noted that AMIS has been developed as a management tool rather than as a descriptive database of attributes, which may limit its usefulness for purposes other than asset management.

### ***Regional visitation to public conservation land***

To illustrate the relevance of AMIS data to ecosystem services, we used data extracted from it to map regional visitation to public conservation land (see Fig. 5). To investigate the spatial coincidence of ecosystem service supply and demand, we also compared visitation (demand) with the availability of public conservation land (supply). The West Coast region which has 84%

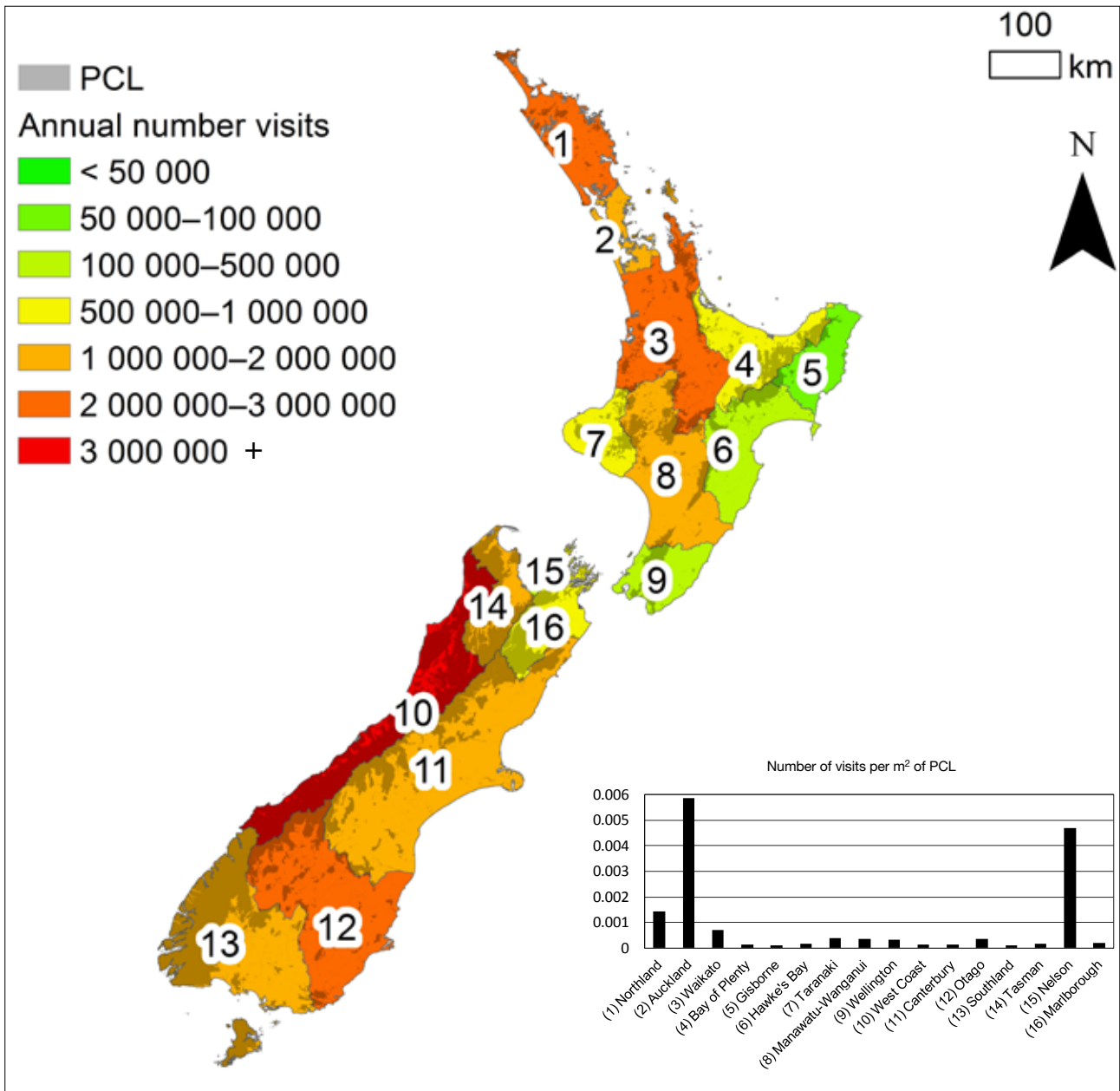

Figure 5. Estimated annual number of visits to public conservation land (PCL) per region. The accompanying graph indicates the number of visits to PCL per square metre of PCL for each region.

Acknowledgements: Visitation data was extracted from DOC's Asset Management Information System (AMIS). Regional boundaries were taken from Statistics New Zealand's 2013 Digital Boundaries dataset.

of its area protected as public conservation land also has the greatest estimated number of visits to public conservation land. The Waikato, Otago and Northland regions had the next greatest estimated number of visits. However, relative to the amount of public conservation land available within each region, visitation was greatest in the Auckland and Nelson regions. Interestingly, both these regions also have higher population densities relative to other regions<sup>41</sup>. It is notable, though, that it is not suitable to use AMIS visitation data at smaller scales due to inaccuracies—indeed, its intended use is for planning and management at a national level, where inaccuracies associated with the data are of little significance.

<sup>41</sup> Regional provisional estimated resident population as at 30 June 2013 (Statistics New Zealand).

### 4.3.2 Permissions Database

DOC's Permissions Database contains information on concessions and permits that have been granted to individuals, groups or companies for activities involving indigenous species (e.g. marine mammal watching, collecting flora samples) or taking place in areas administered by DOC. This information provides examples of where people are deriving benefits from the natural and historic heritage managed by DOC. The types of concessions and permits granted are listed below:

- |                                  |  |
|----------------------------------|--|
| 1. Access/easement               | 19. Marine mammal research                               |
| 2. Accommodation                 | 20. Marine mammal watching                               |
| 3. Aircraft                      | 21. Mining   |
| 4. Aquaculture                   | 22. Non-research   |
| 5. Attractions                   | 23. Permit to hold restricted species of fish            |
| 6. Boating                       | 24. Permits to collect, capture, handle, release or kill |
| 7. Collecting flora activities   | 25. Prospecting  |
| 8. Collecting geological samples | 26. Research   |
| 9. Cultural take                 | 27. Retail   |
| 10. Education/instruction        | 28. Scientific research                                  |
| 11. Events                       | 29. Skifields  |
| 12. Exploration                  | 30. Storage  |
| 13. Extraction                   | 31. Structures   |
| 14. Filming/photography          | 32. Telecommunications                                   |
| 15. General agriculture          | 33. Unidentified   |
| 16. Grazing                      | 34. Vehicle  |
| 17. Guiding                      | 35. Wild animal control                                  |
| 18. Horticulture                 | 36. Wilding causing damage permits                       |

In the context of mapping ecosystem services, this database has the following notable limitations:

1. Spatial information associated with historical records is often unreliable. However, an audit of the spatial information associated with current records is presently underway.
2. Some activities may take place anywhere in public conservation areas and so records may not be location-specific.
3. Spatial data are not recorded for one-off permits.
4. Many activities that occur in public conservation areas or involve indigenous species do not require concessions or permits. Therefore, data from the Permissions Database should be used in combination with other sources to avoid under-representation of values.
5. The effects and monitoring data, which describe the impacts of concession and permitted activities, are not recorded consistently. If this was addressed, such data could be used to assess the trade-offs associated with some ecosystem services—for example, a high concentration of visitors using a particular area may have negative consequences on biological communities or impact on a visitor's experience.
6. Returns information, which includes party size, trip duration, visitor days and number of clients for guiding companies, is collected haphazardly. If this was addressed, such information could be used to quantify and map the benefits people are receiving from various concessions and permits—for example, returns information could be used to map the number of 'client-hours'<sup>42</sup> guiding companies spend at particular locations.

---

<sup>42</sup> In this context, one 'client-hour' refers to the equivalent of one client attending a 1-hour guided trip—for example, a 2-hour trip attended by three clients may be referred to as a six 'client-hour' trip.

### 4.3.3 National Environmental Standards for Sources of Human Drinking Water Database

MfE and regional councils use a GIS-compatible national database of human drinking water source abstraction points and treatment plants to assist with implementation of the National Environmental Standard for Sources of Human Drinking Water<sup>43</sup>. The information in this database originates from Water Information New Zealand<sup>44</sup> (WINZ), which is a database managed by the Institute of Environmental Science and Research (ESR) for the Ministry of Health<sup>45</sup>. This database contains information about drinking water sources, distribution zones, served communities, treatment plants and compliance, which can be used to produce maps of water use for drinking.

We undertook a preliminary analysis to illustrate the potential use of this dataset for ecosystem service mapping. In Fig. 6A, we begin to explore ecosystem service demand by showing water use in terms of the number of people in various parts of New Zealand using water that is suitable for drinking. In Fig. 6B, we then use lakes as an example to explore the contribution that indigenous biodiversity makes to drinking water supply by showing the number of people drinking water sourced from lakes with varying degrees of natural cover within their catchments. In the future, one could also explore whether water from sources with predominantly natural catchments has higher water quality and so requires less treatment—although the necessary data to do this are not recorded in this database.

This preliminary analysis highlights the complexity that is often associated with using a database for a purpose other than that for which it was specifically designed. In this case, the database was designed for management and monitoring purposes, and so the following limitations should be considered when using this database:

1. The accuracy of location data varies, although this is being improved.
2. It is not a legal requirement to register water sources that serve a population of less than 501 people. However, the database does contain information for some sources and treatment plants that serve smaller communities.
3. Compliance and water quality information is provided for water following treatment at treatment plants, so this database does not provide information on water quality before treatment. Consequently, water quality information cannot be used to compare the level of treatment of water sourced from largely protected and/or natural catchments with that from human-modified catchments.
4. Human population data refer to the size of the communities supplied with water from **treatment plants**, some of which are fed by multiple sources. Therefore, population data cannot be specifically linked to individual sources, unless the abstraction rates could be attained. Alternatively, it may be possible to estimate the proportion that each source contributes to a community's water supply based on flow rate and water yield estimates if these were available.
5. Population data may include more than one distribution zone if the treatment plant feeds multiple zones and digital spatial definitions are not available for all distribution zones.

### 4.3.4 Statistics New Zealand data

Statistics New Zealand holds information relating to human population, work and income, health and social themes, the economy, and the environment at a national, regional or meshblock level, with the geographic unit depending on confidentiality and population size. Of particular interest to mapping ecosystem services are industry statistics<sup>46</sup>, such as exports and tourism; and natural

---

<sup>43</sup> [www.mfe.govt.nz/laws/standards/drinking-water-standard-implementation-update.html](http://www.mfe.govt.nz/laws/standards/drinking-water-standard-implementation-update.html) (accessed 1 August 2013).

<sup>44</sup> [www.drinkingwater.esr.cri.nz/default.asp](http://www.drinkingwater.esr.cri.nz/default.asp) (accessed 1 August 2013).

<sup>45</sup> [www.mfe.govt.nz/laws/standards/drinking-water-standard-implementation-update.html](http://www.mfe.govt.nz/laws/standards/drinking-water-standard-implementation-update.html) (accessed 1 August 2013).

<sup>46</sup> [www.stats.govt.nz/browse\\_for\\_stats/industry\\_sectors.aspx](http://www.stats.govt.nz/browse_for_stats/industry_sectors.aspx) (accessed 11 September 2013).

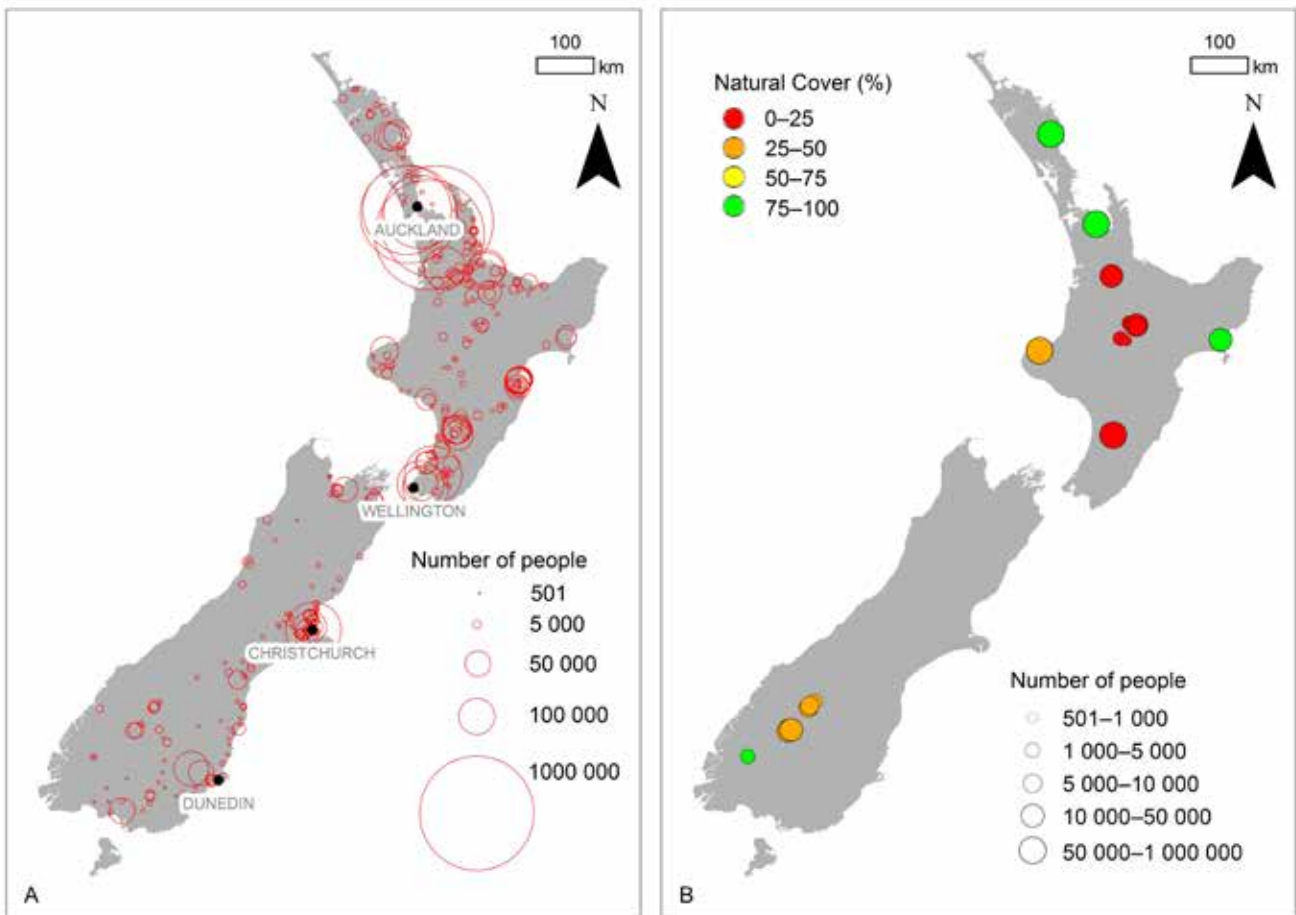

Figure 6. The number of people across New Zealand using A. drinking water from treatment plants; and B. drinking water sourced at least in part from lakes with varying levels of natural cover within their catchments.

Note for Figs 6A & B:

- (i) Population estimates are known for treatment plants, but not sources.
- (ii) Geographic coordinates are known for sources, but not treatment plants.
- (iii) The locations of buffer circles do not correspond with the location of treatment plants; rather, their locations were determined using the mean centre of all sources supplying a single treatment plant.
- (iv) Treatment plants serving less than 501 people were not included, because it is not a legal requirement to register sources serving 500 people or less.
- (v) The size of each buffer circle represents the number of people served by each treatment plant.
- (vi) Treatment plants may be supplied by several water sources.

Note for Fig. 6A:

- (i) Buffer circle size (C, m2) was determined using the following equation:  $C = \sqrt{P} \times 100$ , where P = population size.

Note for Fig. 6B:

- (i) Each point is colour coded according to the average percentage of natural cover within lake catchments for each treatment plant. Each treatment plant may be supplied by sources located within difference catchments.
- (ii) The accuracy of lake source identification has not been verified.
- (iii) See Appendix 3 for description of process used to calculate average percentage of natural cover within lake catchment.

Acknowledgements: Water supply component locations and other water supply data were obtained from the Ministry of Health's water supply database, Water Information New Zealand. Lake catchment information was taken from the Freshwater Environments of New Zealand (FENZ) v1.1 database.

resource statistics<sup>47</sup>, such as the Fish Monetary Stock Account, Water Monetary and Physical Stock Accounts, and statistics relating to the contribution of marine-related industries to the New Zealand economy.

It should be noted, however, that publically available statistics are calculated for categories that may not be conveniently defined for the purposes of an ecosystem services project. For example, no distinction is made between nature-based tourism and other types of tourism; sphagnum

<sup>47</sup> [www.stats.govt.nz/browse\\_for\\_stats/environment/natural\\_resources.aspx](http://www.stats.govt.nz/browse_for_stats/environment/natural_resources.aspx) (accessed 11 September 2013).

moss<sup>48</sup> export statistics are grouped together with other species (which may not be relevant to indigenous biodiversity) in a category called ‘mosses and lichens; of a kind suitable for bouquets or ornamental purposes, fresh, dried or bleached, sphagnum moss’; and mānuka honey is not separated from other honeys. Some data are also subject to privacy or confidentiality constraints; for example, some exports are subject to minimum suppression periods<sup>49</sup>, such as 12 months for the sphagnum moss category.

#### 4.3.5 Discussion

Spatially explicit data relating to human activities and built infrastructure in public conservation areas are available from DOC’s Asset Management and Information System (e.g. visitor number estimates) and Permissions Database (concessions and permits). However, these databases are not necessarily exhaustive or fit-for-purpose. For example, it can be difficult to obtain information on different types of visitor activities—particularly where certain user groups (e.g. hunters) tend to be secretive to protect their favourite or most productive locations (e.g. hunting areas) from further use or exploitation. In addition, much recreational activity in public conservation areas occur independent of visitor assets and DOC’s management (Jeff Dalley, DOC, pers. comm.). Furthermore, some human activities that rely on services provided by indigenous biodiversity and ecosystems occur outside public conservation areas, such as bird-watching or beekeeping, increasing the difficulty of obtaining data for them unless they are regulated. Therefore, in general, data are more likely to be available for activities that are of significance from an economic, political, management and/or legal perspective—for example:

- Human drinking water—The National Environmental Standard for Sources of Human Drinking Water, which came into effect on 20 June 2008, requires regional councils to consider the impacts of activities on drinking water sources in their decision-making. To assist with implementation of this standard, a GIS-compatible database of drinking water source abstraction points and treatment plants was prepared (see section 4.3.3).
- Fisheries—New Zealand’s fisheries are subject to a quota management system, which was introduced in 1986 (Bess 2005; MFish 2011). This system requires catch limits for every fish stock to be set at levels that will ensure their long-term sustainability (MFish 2011). MPI (previously MFish) monitors the amount of fish caught against these limits and enforces financial penalties where limits are exceeded (MFish 2011). However, data are not available for many of the species that are not included in the quota management system. In addition, data on customary and commercial fisheries are generally simpler to obtain due to the reporting that is required by individuals participating in these sectors (Lock & Leslie 2007); there is no compulsory reporting system for the recreational sector, where estimates of recreational catch levels are only obtainable from voluntary surveys (Lock & Leslie 2007) such as the nationwide panel survey of marine recreational fishers conducted from 1 October 2011 to 30 September 2012 (Wynne-Jones et al. 2014).

When using databases relating to human activities and built infrastructure data, it is important to consider their original purpose and any limitations that may be associated with using the data for other purposes. For example, visitor numbers in public conservation areas, which are recorded, modelled or estimated for functional locations (i.e. visitor sites) in AMIS, are largely collected to inform national-level management and planning. As discussed in section 4.3.1, there are inaccuracies associated with these data that are of little significance when used at a national level for planning and management as intended, but will be more important at smaller scales. Some data are also subject to confidentiality constraints, particularly in the case of commercially sensitive information.

---

<sup>48</sup> This is an indigenous species harvested from natural areas in New Zealand for use in horticulture as a potting medium because of its high water-holding capacity and sterility (Buxton et al. 1996).

<sup>49</sup> [www.stats.govt.nz/about\\_us/policies-and-protocols/trade-confidentiality/confidential-items-exports.aspx](http://www.stats.govt.nz/about_us/policies-and-protocols/trade-confidentiality/confidential-items-exports.aspx) (accessed 9 August 2013).

Despite the absence of or difficulty in obtaining human use data for some activities, it may still be possible to estimate the spatial distribution of these activities by developing alternative indicators (see section 6.1). Such indicators may be developed using types of infrastructure and amenities that are specifically associated with certain activities—for example, camping occurs at campsites; boating activities occur around and near boat ramps; and surf life saving clubs are associated with surfing and ocean swimming. Where spatial information on certain indicators is not readily available or is scattered across a variety of sources, it may need to be collated into a single database. The limitations of such datasets should also be carefully considered. For example, the distribution of huts in public conservation areas alone would not be a robust indicator of visitation or recreation. This is because factors other than visitation (including historic factors) may influence the distribution of huts; and, although new huts may be built in response to growing demand, their distribution does not capture the more dynamic nature of visitation, which varies within and between years.

Alternatively, social surveys could be used to determine where humans are deriving benefits from ecosystem services. For example, public participation GIS (PPGIS) could be used to determine preferred bird-watching locations, and GIS and statistical analytical techniques could then be used to determine which spatially explicit biotic and abiotic variables are good predictors for these locations. Question-based surveys could also be used, where questions have been designed to identify spatially explicit criteria (e.g. 'How far do you normally travel to participate in bird watching?'). SeaSketch (see section 5.1.3) is an example of a survey tool which allows users to map their responses to such questions. It should be noted, however, that social values are subjective, changeable and emergent (see section 6.4; Allen et al. 2009).

## 4.4 Ecosystem service data

In New Zealand, national-level mapping and GIS-based modelling have been carried out for a range of ecosystem services (see Table 5). Several key ecosystem service initiatives are discussed below as examples to illustrate the types and extent of spatial data available, and their relevance to conservation.

### 4.4.1 Ecosystem Services for Multiple Benefits

Since 2009, Landcare Research has been running a research programme called Ecosystem Services for Multiple Benefits, which is currently incorporated into core funding (Anne-Gaelle Ausseil, Landcare Research, pers. comm.). To date, the following ecosystem services have been modelled across terrestrial New Zealand using spatial indicators:

- Climate regulation (Dymond et al. 2012; Ausseil et al. 2013)
- Provision of natural habitat (Ausseil et al. 2011b, 2013)
- Provision of clean water using nitrate leaching and phosphorus leaching indicators (Ausseil et al. 2013; Dymond et al. 2013b)
- Water-flow regulation (Dymond et al. 2012; Ausseil et al. 2013)
- Erosion control (Dymond et al. 2010, 2012; Ausseil et al. 2013)
- Food and fibre (Ausseil et al. 2013)

The development of these models has been a significant step forward in the assessment of ecosystem services at a national level in New Zealand. It is important, however, to recognise the research motivation behind these studies, which aimed to model ecosystem services provided by managed and natural ecosystems, meaning that a clear distinction was not always made between these. By contrast, DOC is particularly interested in the services and benefits provided by indigenous species and ecosystems. Despite these differences, some of the Ecosystem Services for Multiple Benefits work is of direct relevance to indigenous biodiversity and conservation. For example, a spatially explicit erosion model for predicting landslide susceptibility (e.g. Dymond



Table 5. Summary of ecosystem services of relevance to indigenous biodiversity that have been addressed by New Zealand studies and initiatives that included mapping or the development of spatial indicators at a national level.

BIOME	ECOSYSTEM SERVICE	REFERENCE/NAME OF DATABASE
<b>Freshwater</b>	Water regulation, supply and quality	• Dymond et al. 2012, 2013b; Ausseil et al. 2013
	Recreation	• Waters of National Importance—MfE 2004a
	Environmental/biodiversity values	• Freshwater Ecosystems of New Zealand (FENZ)
<b>Terrestrial</b>	Climate regulation	• Dymond et al. 2012; Mason et al. 2012; Ausseil et al. 2013
	Erosion control	• Dymond et al. 2010; Dymond et al. 2012; Ausseil et al. 2013
	Landscape values	• Brown & Brabyn 2012b (Note: This was a methodological pilot study only, so the resulting maps cannot be used as a final product)
	Recreation opportunities	• Joyce & Sutton 2009; Brabyn & Sutton 2013
<b>Estuarine</b>	<i>A spatial definition for estuaries needs to be completed before estuarine ecosystem services can be mapped at a national level</i>	
<b>Marine</b>	Ecosystem services and estimations of their economic values associated with habitat types for marine protected areas	• van den Belt & Cole 2014
	Marine environmental values:	• Beaumont et al. 2008, 2009; MacDiarmid et al. 2008
	• Species diversity, richness and rarity	
	• Habitat distribution and characteristics	
	• Areas of special biological/ecological significance	• Batstone et al. 2009; Samarasinghe et al. 2009
	Marine economic values:	
• Coastal industry value-added		
• Fisheries' values at risk	• Allen et al. 2009; Visitor Solutions Ltd et al. 2012	
• Coastal amenity values		
Marine social value:		
• Recreation and tourism		
• Identity values		

et al. 2006) has useful land management applications for DOC as well as external stakeholders—this includes the finding that if the Motueka catchment was completely covered by indigenous forest, the predicted mean sediment discharge would be less than half of that under present land use and five times smaller than that under intensive land use (no production forestry) (Dymond et al. 2010); and that sediment yield could be reduced by 50% if the Manawatu catchment was afforested with indigenous shrubland or pine forest (Ausseil & Dymond 2010). DOC could use such information to promote the planting of indigenous woody species for soil conservation purposes on privately owned land, which may provide the additional benefit of wildlife corridors connecting natural habitat remnants in human-modified landscapes (e.g. Jansen 2005).

The relevance of this work to conservation is also demonstrated at the St James Conservation Area, where similar approaches to the above national models have been applied at a local scale to investigate whether management of the area can be optimised to deliver multiple ecosystem services, including public recreation, while enhancing, or at least maintaining, indigenous biodiversity (Carswell et al. 2013). The management principles developed for this area may be applicable to other areas managed by DOC and other stakeholders (Carswell et al. 2013).

There is also an opportunity to build on this work by developing models that place a greater emphasis on the role that indigenous land cover classes and ecosystems play in the generation of the services mentioned above—although the success of such work may be limited until more comprehensive and higher resolution spatial data of indigenous land cover and ecosystems are developed. In addition, other research gaps may also need to be addressed. For instance, carbon sequestration by native species is generally less understood than by exotic species

(Johnson 2009)—an area in which some research is currently being conducted in New Zealand<sup>50</sup> (e.g. Carswell et al. 2009). There may also be opportunities to incorporate Phillips & Marden's (2010, 2012) research on the stabilising characteristics of native and exotic plant species into future erosion control models (Anne-Gaelle Ausseil, Landcare Research, pers. comm.); and a wood production (fibre) model could be developed for indigenous species for which growth and productivity estimates are available, e.g. tōtara (*Podocarpus totara*) (Bergin & Kimberley 2003) and kauri (*Agathis australis*) (Steward 2011).

On-going work in this research programme includes improving models of indicators for water quality (e.g. *Escherichia coli*) and pollination, and better understanding the role of land management practices (e.g. riparian planting) on ecosystem services (Dymond et al. 2014).

#### 4.4.2 Mapping the values of New Zealand's coastal waters

MPI have mapped the environmental (Beaumont et al. 2008), social (Allen et al. 2009) and economic (Batstone et al. 2009) values associated with New Zealand's marine and coastal environments. A Delphi process was used to identify subcomponents of these values, suitable datasets and analysis methods, and to receive feedback on the resulting value maps. The indicators used for each of the three value categories are summarised in Table 6.

Beaumont et al. (2009) and Samarasinghe et al. (2009) conducted meta-analyses on the environmental and economic values, respectively, to examine the spatial distributions of attribute values and to identify areas of coincidence among high-value attributes. A meta-analysis on Allen et al.'s (2009) social values is also planned in the future (Daniel Kluza, MPI, pers. comm.).

Each of the authors acknowledged several limitations associated with the data used in their projects. For the environmental values project, these included gaps in the spatial distribution of data, issues with data accuracy, and a lack of sampling standardisation across all data sources and locations. For the social values project, examples of limitations included gaps in the data (e.g. for seafood gathering), and sites of local significance being excluded from iconic and archaeological sites, which only included tourist and visitor destinations. Examples for the economic values project included census employment records not capturing seasonal changes, which may be important for some industries (e.g. tourism); and some data being subject to confidentiality constraints and therefore needing to be aggregated to an appropriate scale. The spatial extents of the projects also varied depending on the mapped characteristic and the data used. Before using the data for other purposes, it is also important to consider that the GIS databases were developed for use in a decision-support tool for risk management, contingency processes and incursion responses. Since this influenced the choice of indicators, those developed may not be the best option for other purposes.

#### 4.4.3 Ecosystem goods and services in marine protected areas

DOC recently commissioned Massey University to produce a report on ecosystem services provided by New Zealand's marine and coastal environment and its marine protected areas (van den Belt & Cole 2014). This report provided an overview of ecosystem service theory, classification systems, valuation methods and spatial modelling tools (e.g. MIMES, InVEST, SeaSketch), described how these can be used to manage and protect marine areas, and discussed data and knowledge gaps. van den Belt & Cole (2014) also applied the rapid ecosystem services assessment (RESA) method to seven marine areas, including the EEZ (and Territorial Sea), the Banks Peninsula Marine Mammal Sanctuary, and five marine reserves (Whangarei Harbour, Poor Knights Islands, Te Angiangi, Westhaven/Te Tai Tapu and Piopiotahi/Milford Sound). This process included: (i) creating an inventory of biomes/habitat types and the ecosystem services associated with each of these; (ii) using GIS to map the spatial distribution of biomes

---

<sup>50</sup> [www.landcareresearch.co.nz/science/greenhouse-gases/carbon-measurements](http://www.landcareresearch.co.nz/science/greenhouse-gases/carbon-measurements) (accessed 25 June 2013) and [www.tanestrees.org.nz/currentprojects.html](http://www.tanestrees.org.nz/currentprojects.html) (accessed 26 June 2013).

Table 6. Indicators used to map the environmental (Beaumont et al. 2008), social (Allen et al. 2009) and economic (Batstone et al. 2009) values associated with marine and coastal areas in New Zealand.

VALUE	VALUE SUBCOMPONENT		MAPPED CHARACTERISTICS OR FEATURES
	LEVEL 1	LEVEL 2	
Economic	Amenity value provided by the coast	Residential land value based on Quotable Value Ltd data	<ul style="list-style-type: none"> <li>Total land value (\$) for coastal area units.</li> </ul>
	Coastal industry value-added	Employment and industry productivity	<ul style="list-style-type: none"> <li>Economic value added (\$) by selected industries per geographic unit based on employment data and the national total value added for each industry. For each industry, <math>v = n \div N \times V</math> where <math>v</math> = estimated value-added for each geographic unit, <math>n</math> = no. employees for each geographic unit, <math>N</math> = no. employees for the whole country and <math>V</math> = value-added for the whole country.</li> </ul>
	Fisheries values at risk	Catch data, quota share prices, free on board export prices	<ul style="list-style-type: none"> <li>Fisheries value (\$) at risk per fisheries statistical area for selected fisheries.</li> </ul>
Environmental	Areas of special biological/ecological significance	Area of marine protected areas (MPAs), sanctuaries and restrictions  Marine mammal distribution	<ul style="list-style-type: none"> <li>Proportion of protected areas within each coastal cell.</li> <li>Species distributions, including 100% and 90% ranges, distribution hotspots, and known colonies.</li> </ul>
	Habitat distribution and characterisation	Habitat area for biological habitat types (mangroves, seagrass and biogenic reefs) and physical habitat categories (as defined by the Marine Environment Classification)  Primary productivity	<ul style="list-style-type: none"> <li>Habitat distributions, the proportion of each habitat type within each coastal cell and a measure of estimated habitat diversity.</li> <li>Annual average near-surface chlorophyll a concentration within a coastal cell.</li> </ul>
	Species diversity, richness and rarity	At-risk or threatened marine species  Non-indigenous species  Overall biodiversity for rocky reef fish, rocky reef invertebrates, vertical rock wall communities and invertebrates (sponges, bryozoans, polychaetes, molluscs, echinoderms and arthropods)  Taxon-specific diversity for sponges, bryozoans, polychaetes, molluscs, echinoderms, arthropods, algae and diadromous fish	<ul style="list-style-type: none"> <li>Species distributions.</li> <li>Total records and genera richness.</li> <li>Species richness and biomass were modelled for rocky reef fish, rocky reef invertebrates and vertical rock wall communities.</li> <li>Diversity indices were derived for invertebrates.</li> <li>Total records, total species, species richness, average taxonomic distinctness, variation in average taxonomic distinctness, species rarity and species composition.</li> </ul>
Social	Identity values	Archaeological sites  Iconic landscapes	<ul style="list-style-type: none"> <li>Locations of archaeological sites listed by the New Zealand Archaeological Association (NZAA) as sites for 'cultural tourists' to visit.</li> <li>Locations of sites considered an iconic part of the coast due to their natural beauty or history.</li> </ul>
	Utility values	Boating—kayaking Boating—yachting and cruising  Diving Number of land-based activities Seafood gathering and fishing  Surfing	<ul style="list-style-type: none"> <li>Locations of sea kayak hire companies.</li> <li>Locations of marinas and harbours where yachts can berth or moor overnight, and yacht clubs.</li> <li>Locations of diving sites.</li> <li>Locations of beaches.</li> <li>Locations of fishing clubs, water quality monitoring sites, and areas of the coast used for line fishing, set and drag netting, white baiting, and shellfish gathering.</li> <li>Locations of surfing spots.</li> </ul>

and measure their area (hectares); (iii) using the benefits-transfer approach to assign economic values (\$/hectare/year) to each ecosystem service based on available literature; and (iv) estimating the total economic value (\$/year) associated with each ecosystem service for each biome by multiplying each biome's total area by the economic value (\$/hectare/year) assigned

to each ecosystem service. van den Belt & Cole (2014) then assigned scores (based on expert opinion) indicating the likelihood that a change in ecosystem service supply, demand and value would occur following implementation of MPA status.

Van den Belt & Cole (2014) noted that while there are limitations to such an approach (e.g. difficulties in finding good quality studies of similar situations, sufficient consideration of how characteristics change over time and space, and addressing transfer errors), it can be useful for providing an indication of magnitude and so signalling that substantial value is currently invisible to decision-makers.

#### 4.4.4 Geodatabase for Mapping Marine Recreational Use and Value

DOC also recently commissioned the development of a geodatabase for mapping indicator data relating to the recreational use and value of New Zealand's coastal and marine environment (Visitor Solutions Ltd et al. 2012). This geodatabase includes location data for coastal facilities, amenities and organisations, which indicate recreational use of the area as well as known or popular locations for various recreational activities. These data were used to develop a Spectrum of Marine Recreation Opportunities (SMARO) for part of the New Zealand coastline where sufficient data existed, based on an approach proposed by Orams (1999). This could be used to provide a general overview of the recreational activity and use level around the coastline. However, further data collection is required before the classification can be applied to all coastal areas and the accuracy of the data stored in the geodatabase has not yet been reviewed, making its reliability uncertain.

#### 4.4.5 Water Bodies of National Importance (WONI)

The WONI project (MfE 2004a, b) was part of the New Zealand Government's Sustainable Water Programme of Action<sup>51</sup> (2003–08), which aimed to determine how nationally important values in water could be protected. The project aimed to identify potential water bodies of national importance for the following categories: natural heritage (biodiversity and geodiversity); recreation; irrigation; energy (hydroelectric and geothermal); industrial and domestic use; tourism; cultural and historical heritage; and Māori cultural values.

One issue with this project was that it was difficult to consistently determine the importance of rivers across all categories. This resulted in only a few water bodies being identified as nationally important for some categories and many being identified for others. The scale (e.g. sub-catchment, catchment, entire river) at which importance was determined also varied between categories. Although the data could be used to produce maps of nationally important water bodies for each of the categories, such as the maps for recreation values (see Fig. 7A & B)<sup>52</sup>, the lists of nationally important water bodies are already several years old and in all likelihood require updating. Comparison and summing of overall values would also be difficult because of the inconsistencies described above.

#### 4.4.6 Sustainable Land Use Research Initiative (SLURI), and the Soil and Land Use Alliance (SLUA)—soil natural capital valuation

The Sustainable Land Use Research Initiative (SLURI)<sup>53</sup> is a government-funded national research programme that is being carried out by Landcare Research, Plant and Food Research, and AgResearch to maintain and manage New Zealand's soils. One of its objectives is to quantify and value soil natural capital in New Zealand, with the purpose of informing environmental

---

<sup>51</sup> <http://web.archive.org/web/20150121122956/http://mfe.govt.nz/issues/water/prog-action> (accessed 23 April 2015).

<sup>52</sup> Previously available from MfE's website. See <http://web.archive.org/web/20130222082711/http://www.mfe.govt.nz/issues/water/prog-action/map-recreation-si.pdf>; <http://web.archive.org/web/20130222082659/http://www.mfe.govt.nz/issues/water/prog-action/map-recreation-ni.pdf>; and <http://web.archive.org/web/20130222082727/http://www.mfe.govt.nz/issues/water/prog-action/map-recreation.pdf> (accessed 23 April 2015).

<sup>53</sup> [www.sluri.org.nz/Objectives/Display/3](http://www.sluri.org.nz/Objectives/Display/3) (accessed 9 December 2013).

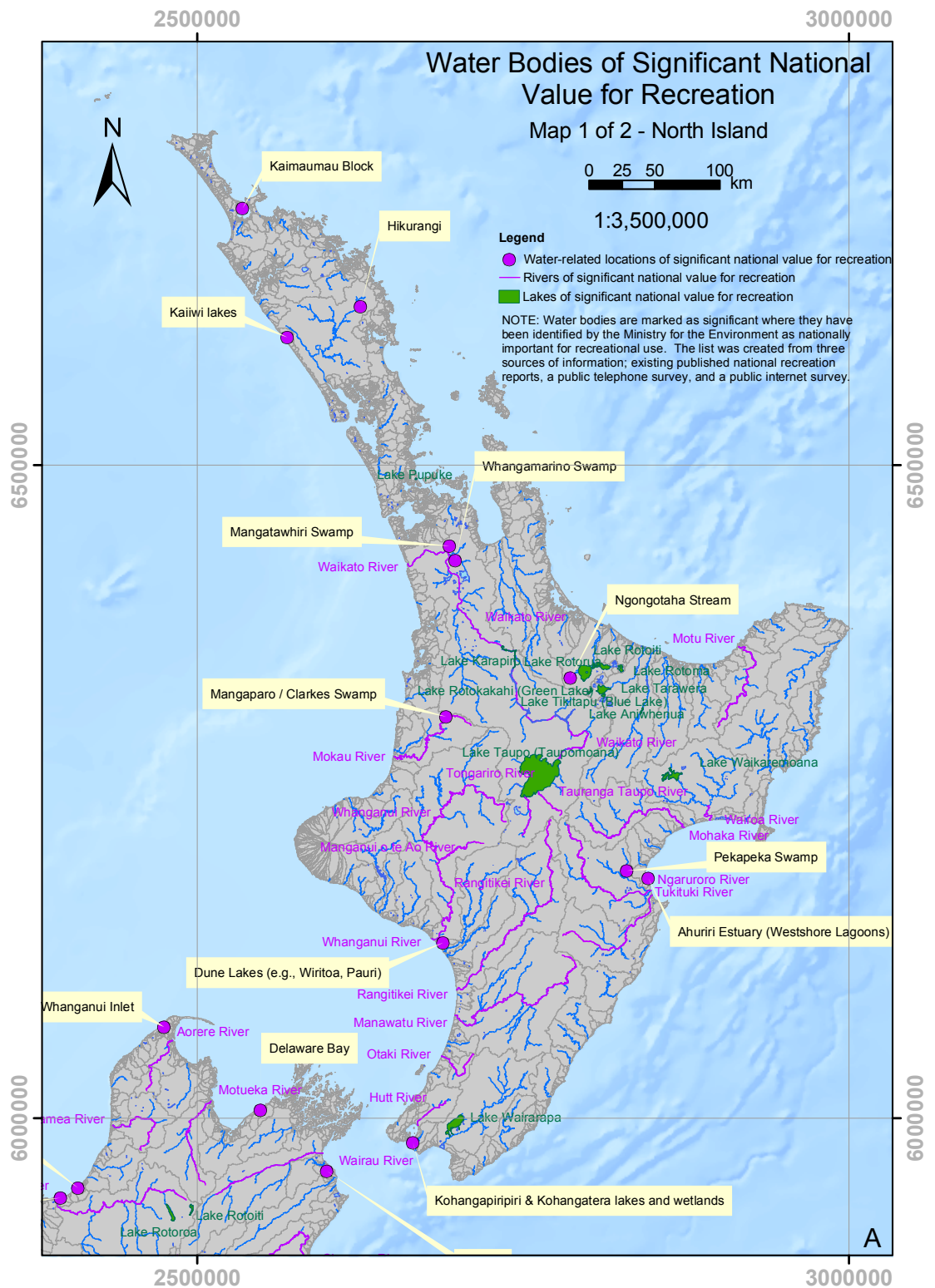

Figure 7. Water bodies of significant national value for recreation for A. the North Island and B. the South Island.

Acknowledgements: Maps created by Ministry for the Environment based on the Water Bodies of National Importance (WONI) Project (MfE 2004a).

policy and land management. This involves using knowledge about the functioning, health and resilience of New Zealand's soils to value the ecosystem and productive services provided by them, with the aim of developing evidence-based knowledge and tools that can be applied at a range of scales to New Zealand's arable, pastoral and horticultural sectors; and integrating and assessing these services by defining their natural capital value, and determining the impacts and trade-offs of different land use patterns on these values at various spatial scales (SLUA 2012).

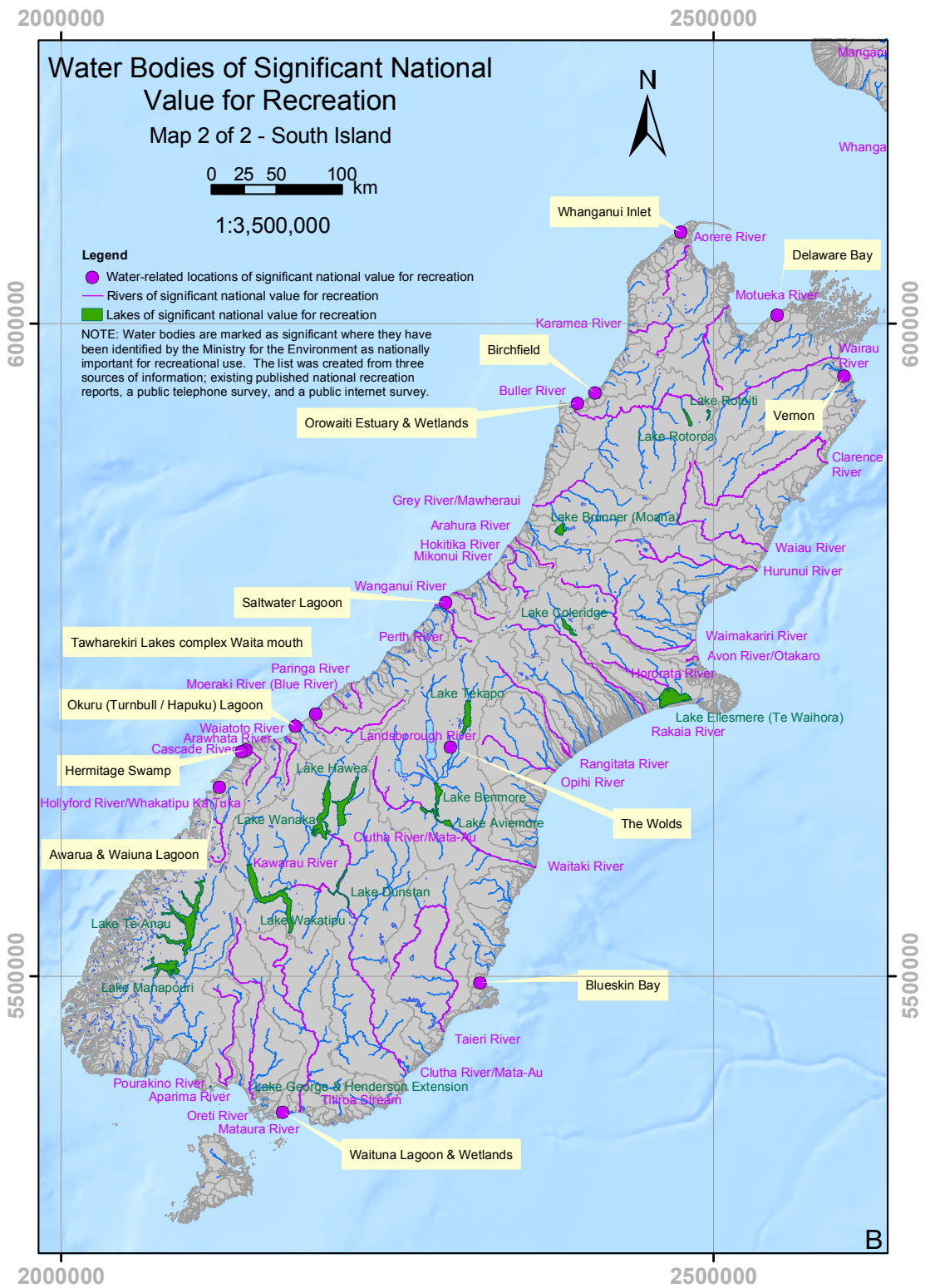

Figure 7 continued.

This work includes developing spatial mapping and economic valuation methods (e.g. Carrick et al. 2010; Hewitt et al. 2010, 2012) to quantify soil natural capital.

The Soil and Land Use Alliance (SLUA)<sup>54</sup> formed in 2011 and includes AgResearch, Landcare Research, Scion, and Plant and Food Research. Its major priority is to deliver coordinated research on the sustainable management of soil and land resources that contributes to the economic

<sup>54</sup> [www.nlrc.org.nz/connect/organisations/slua](http://www.nlrc.org.nz/connect/organisations/slua) (accessed 10 December 2013).

growth of New Zealand. Recently, the Parliamentary Commissioner for the Environment (PCE) contracted SLUA to undertake a scoping study on the reporting of soils in future as part of National State of the Environment reporting (see SLUA 2012). A recommendation arising from this was that an ecosystem services element should be included in the existing soil reporting framework. Several spatial and aspatial data sources that would be useful for this were highlighted (see SLUA 2012) and it was concluded that the necessary resources were available to make this achievable. Research associated with both SLURI and SLUA is likely to make a valuable contribution to this if it is pursued.

#### 4.4.7 Discussion

In New Zealand, the ecosystem services in terrestrial ecosystems, freshwater ecosystems, and marine and estuarine ecosystems have often been mapped separately, resulting in different approaches being developed and used both within and between biomes. While each approach has its merits and weaknesses, it is important that a standardised approach is developed for use across all biomes, not only to make comparison easier, but also to assist with the development of a national view of the state and trend of ecosystem services in all of New Zealand's environments. This need for methodological consistency for robustly quantifying and mapping ecosystem services has been recognised by many authors (Maes et al. 2012, 2013; Martinez-Harms & Balvanera 2012; Crossman et al. 2013). Ecosystem service mapping also needs to be conducted using an integrative holistic approach that recognises the connectivity between ecosystems and the fact that ecosystem services transcend boundaries (e.g. see Savage et al. 2012) between ecosystems and biomes. For example, land use intensification is often associated with declines in freshwater ecosystem services such as clean drinking water and recreation as a result of increases in sediment, faecal contamination and nutrient loads (see section 6.6.2). This, in turn, affects coastal and estuarine habitats (e.g. Thrush et al. 2004) and the ecosystem services they provide, such as fisheries and recreation. In addition, many ecosystem services cross international boundaries, such as the bird watching opportunities provided by migrating species (e.g. godwits).

Relatively little work has been invested in mapping cultural ecosystem services compared with other service categories in New Zealand. The exception to this is the work of Allen et al. (2009) and Visitor Solutions Ltd et al. (2012), who mapped recreation and tourism values in marine environments; MfE (2004a), who mapped potential water bodies of national importance for recreation (see Fig. 7A & B); and research by Joyce & Sutton (2009) and Brabyn & Sutton (2013), who mapped recreational opportunities in the terrestrial environment. This situation is similar to that found in other parts of the world, where most ecosystem service mapping studies have tended to focus on provisioning and regulating services rather than cultural services (Casalegno et al. 2013). Furthermore, this is also the case for ecosystem services research in general, where the assessment of the status of and trends in cultural ecosystem services is one of the most difficult and least accomplished tasks (Schaich et al. 2010). For example, a mere 2% of pages within the 2005 publication of the MA were devoted to cultural ecosystem services (Tengberg et al. 2012) and only 11% of ecosystem service indicators corresponded to cultural services—84% of which were in turn focussed on recreation and tourism (Hernández-Morcillo et al. 2013). Such assessments are challenging for various reasons, including difficulties in clarifying definitions and purposes, and understanding the processes to be measured (Hernández-Morcillo et al. 2013); issues with relating ecosystem functions and characteristics to human needs and wants (Plieninger et al. 2013) and cultural ecosystem services (Hernández-Morcillo et al. 2013); and the subjectivity of people's appreciation of cultural services (Plieninger et al. 2013). In addition, there are difficulties associated with quantifying these services (Plieninger et al. 2013). For example, the practice of classifying services into distinct and separate categories to avoid double counting ignores the complexity associated with cultural ecosystem services—i.e. to avoid double counting in economic valuations, a given service indicator (e.g. a historic track) may not be included in more than one service category, despite indicators often being associated with an extensive web of interlinked services and values (e.g. a historic track may have spiritual, heritage, aesthetic and identity values associated with it, and it may be used for recreation and tourism).

Another problem is that the ecosystem services concept is mainly based on natural science paradigms (Tengberg et al. 2012). Cultural services are not purely ecological phenomena, but rather the outcome of complex and dynamic relationships between ecosystems and humans in landscapes through time (Plieninger et al. 2013). However, despite these challenges, it is particularly important that this knowledge gap be addressed because cultural services: (i) represent one of the strongest incentives to support environmental and biodiversity conservation (Schaich et al. 2010; Hernández-Morcillo et al. 2013; Satterfield et al. 2013), particularly for people from developed countries (Schaich et al. 2010); (ii) are irreplaceable once degraded (Hernández-Morcillo et al. 2013), unlike some provisioning and regulating services that may be replaced by socio-economic means (e.g. replacing drinking water from a polluted well with bottled water) in developed societies (Plieninger et al. 2013); and (iii) play an essential role in enhancing human welfare (Hermann et al. 2011). In addition, under-representing cultural services in ecosystem service assessments, landscape planning and land use decisions will cause bias, threatening the creation of meaningful links between society and nature (Hernández-Morcillo et al. 2013), and undermining the purpose and integrity of the ecosystem services framework.

Since the central idea of the ecosystem services framework is to enable a comprehensive set of values and services to be accounted for in decision-making using an interdisciplinary, transdisciplinary and holistic approach (Tengberg et al. 2012), it would be appropriate to include a wider set of paradigms in its development and application. In line with this, several authors have suggested the need to link ecosystem services research with approaches from the arts and humanities (Church et al. 2014), quantitative and qualitative methodologies from the social sciences (Church et al. 2014), and cultural landscape research (Schaich et al. 2010; Hermann et al. 2011; Tengberg et al. 2012; Milcu et al. 2013; see section 6.2.1) in an attempt to better recognise cultural ecosystem services, including intangible and tangible benefits. The UK NEA also concluded that there is a need for more theoretical development and substantial innovation in data collection, and quantitative and qualitative analysis of cultural ecosystem services (Church et al. 2014). In response, the UK NEA Follow-on (UK NEAFO) further elaborated on the concept of cultural ecosystem services and developed indicators based on publicly available data to aid policy and decision-making. This is discussed further in section 6.1.3.



## 5. GIS-based ecosystem service assessment tools

Several GIS-based tools that assess ecosystem services and the trade-offs that occur as a result of management interventions have been developed in recent years to aid decision-makers (e.g. ARIES, Co\$ting Nature, Envision, GUMBO, InVEST, LUCI, MIMES, SolVES, NZ-Farm). Appendix 1 contains a summary of several of these tools. There are also other traditional decision-support tools and existing mapping and modelling approaches available that were not necessarily originally designed for ecosystem service assessments but may nonetheless be used or adapted for this purpose—which may be more trusted if already in use for other projects or known locally (Bagstad et al. 2013). With so many tools to choose from, it can be difficult for decision-makers to identify which tools are appropriate for their applications or whether modelling is necessary (Vigerstol & Aukema 2011).

When choosing an appropriate tool, it is important to consider model design and purpose versus purpose of application, spatial and temporal analysis scales, computational intensity, data availability and needs, underlying modelling equations, and the level of validation the model has undergone (Vigerstol & Aukema 2011). To date, there has been little systematic review, evaluation or comparison of these tools in terms of their strengths, weaknesses and applicability to various settings, possibly due to the difficulty in defining an ecosystem service assessment tool (Bagstad et al. 2013). However, Bagstad et al. (2013) recently conducted a review of ecosystem service assessment tools (including aspatial tools) and compared seven of these in the San Pedro River watershed in southeast Arizona, USA. This comparison included investigating the trade-offs that need to be considered when choosing between available tools (see Table 7). Vigerstol & Aukema (2011) also compared two ecosystem service assessment tools with two hydrological tools for modelling freshwater ecosystem services and made some broad recommendations to guide decision-makers in choosing an appropriate tool.

In all likelihood, such comparisons will become more common as ecosystem service assessments are mainstreamed into decision- and policy-making. Examples of upcoming projects comparing GIS-based ecosystem service assessment tools include:

- A project led by Victoria University of Wellington<sup>55</sup> comparing the use of InVEST, LUCI and ARIES in the Conwy catchment in north Wales
- A project led by the Centre for Ecology and Hydrology (CEH), Natural Environment Research Council (UK)<sup>56</sup>, comparing the use of InVEST, ARIES and Co\$ting Nature in Sub-Saharan Africa (James Bullock, CEH, pers. comm.)

The second of these projects aims to identify the simplest adequate ecosystem services modelling framework to inform effective policy and management interventions for poverty alleviation at appropriate spatial and temporal scales. The outcomes of this project will enable decision-makers to best use existing ecosystem service models to inform regional and national land use/cover change policies that support the management of ecosystem services, and promote equality and justice among ecosystem service beneficiaries; and set priorities that determine where the investment of scarce resources should occur in the management of ecosystem services (James Bullock, CEH, pers. comm.).

---

<sup>55</sup> Contact person: Bethanna Jackson, Victoria University of Wellington, bethanna.jackson@vuw.ac.nz ([www.victoria.ac.nz/sgees/about/staff/bethanna-jackson](http://www.victoria.ac.nz/sgees/about/staff/bethanna-jackson); accessed 11 September 2014).

<sup>56</sup> Contact person: James Bullock, Centre for Ecology and Hydrology, Natural Environment Research Council, UK, jmbul@ceh.ac.uk ([www.espa.ac.uk/projects/ne-1001322-1](http://www.espa.ac.uk/projects/ne-1001322-1); accessed 6 May 2014).

## 5.1 Selecting GIS-based tools for conservation purposes in New Zealand

Before DOC invests in one or more of these tools, it first needs to establish its specific needs and which tool(s) will best meet them. If multiple different needs exist, it may be necessary to use more than one tool. A comprehensive needs analysis would include some of the following questions:

- What demand exists for such a tool and who would be the primary users or beneficiaries (e.g. operations, policy-makers, public engagement and partnerships staff, external stakeholders)?
- What benefits would the organisation gain if it invested in a particular toolset?
- To what extent would the use of the tool influence management decisions and policy?
- What was the tool's original purpose, and is it compatible with the organisation's need or application?
- Given that each tool incorporates a certain perspective, value set or bias, are its philosophical foundations consistent with that of the organisation?
- What can the organisation achieve by building on existing systems rather than investing in a new system or tool?
- What are the costs associated with the tool, in terms of data needs, financial investment, time and expertise?
- Which ecosystem service assessment tool best works with existing datasets and systems to offer additional benefits?
- Is the tool suitable for New Zealand conditions?
- Which services have been fully developed?
- To which temporal and spatial scales is the model most suited?
- What are the underlying algorithms and how were the underlying response-curves created?
- What are the strengths and weaknesses of the toolset?
- Has the tool or model been adequately validated?

Such an assessment would also need to consider the possibility of adapting systems that are already used by the organisation or other significant stakeholders. For example, the River Values Assessment System (RiVAS—see section 6.6.4) has been used by some regional authorities to identify river values, but is not yet fully GIS-compatible.

In the following sections, we first discuss LUCI as an example of an existing GIS-based ecosystem service assessment tool that has the potential to be used for conservation purposes in New Zealand, and then go on to present Zonation and SeaSketch as examples of tools that are currently used by DOC for conservation planning and prioritisation.

### 5.1.1 LUCI: Land Utilisation and Capability Indicator GIS Toolbox

LUCI, which started off as Polyscape (see Bagstad et al. 2013; Jackson et al. 2013), is an integrated, spatially explicit, multi-ecosystem services framework that identifies the impact and trade-offs of land management actions from a very fine (subfield) scale to a regional or national level. It also has the unique and efficient ability to route the flow of water, chemicals and sediment at a high resolution using readily available data (e.g. elevation, slope, hydrography, land cover—see Bagstad et al. 2013). It is being applied in the United Kingdom and New Zealand (and elsewhere) to identify how land management can improve carbon, water flow and quality, and biodiversity while maintaining productivity. LUCI produces single service maps that identify high to low existing value under a particular land management scenario, including where there are opportunities to employ targeted land management practices (e.g. planting vegetation to reduce erosion and improve water quality) to improve the provision of services. It also has the

capacity to produce multi-service maps used to identify service trade-offs under various land management scenarios. In their recent review of such tools, Bagstad et al. (2013) concluded that LUCI was 'potentially feasible for widespread use given improved guidance on tool use and feasibility of conducting a full stakeholder engagement process'.

LUCI is under continual development, with its developers working with other organisations to customise it for the New Zealand context (Dr Bethanna Jackson, Victoria University of Wellington, pers. comm.). Therefore, there may be an opportunity to customise it for conservation-related applications. For example, LUCI's scenario-analysis capability could be used to better articulate the potential impacts of resource use decisions, including with regard to resource consent and concession applications. LUCI could also be used to inform upper catchment flood management, where ecosystem services provided by indigenous species and ecosystems (e.g. wetlands, riparian vegetation and targeted plantings) are utilised rather than artificial measures (e.g. artificial flood retention areas and stopbanks). In addition, such a tool could be used by DOC or other organisations with an interest in conservation in their partnerships work, where it is important that mutual benefits to both partners are achieved. For example, the DOC-Fonterra partnership<sup>57</sup> includes developing farm plans that incorporate biodiversity management (Philippe Gerbeaux, DOC, pers. comm.)—a tool such as LUCI could be used to inform such plans to optimise both production and biodiversity benefits.

Such a tool may also be used in the future to further conservation in areas outside public conservation land (e.g. agricultural landscapes), including where conservation is contentious due to conflicting social, economic and environmental values, by:

- Helping to prioritise the protection and/or restoration of natural remnants in agricultural landscapes that have the highest cost-benefit with respect to conservation, production and societal values
- Identifying and retiring land that is uneconomical to farm (e.g. if it is prone to flooding or erosion), and setting it aside to be managed for biodiversity values and other ecosystem services (e.g. cultural ecosystem services such as recreation and identity values)
- Helping farmers and land managers to mitigate or reduce their impacts on other ecosystem services and the environment (e.g. spatially explicit ecosystem service models can be used to identify areas where targeted plantings of indigenous vegetation are likely to maximise water quality benefits by reducing sediment and nutrient inputs into waterways)

In this way, LUCI could help to achieve conservation gains such as greater protection of lowland areas, which are currently poorly represented in New Zealand's protected areas; better connectivity of natural habitats for the benefit of indigenous biodiversity (function only available for the UK at present); and benefits to aquatic biodiversity associated with improved water quality. Moreover, it could help land managers to operate within environmental limits, including for water allocation and water quality, which is currently being addressed by the Land & Water Forum<sup>58</sup>.

### 5.1.2 Zonation

DOC currently uses Zonation software for ecosystem and species prioritisation, and has successfully piloted its use for historic heritage management prioritisation. If it were also to be used for ecosystem service mapping, the following considerations would need to be made:

1. Zonation for ecosystem prioritisation is currently not run across all ecosystems on public conservation land—rather, ecosystem classification data are based on expert estimation reviewed by local staff and are only for approximately 95 management units selected to represent the best examples of New Zealand's ecosystems. Therefore, Zonation would have greater potential for ecosystem service mapping if higher resolution and more comprehensive land cover and ecosystem spatial data were developed.

---

<sup>57</sup> [www.doc.govt.nz/about-us/our-partners/our-national-partners/fonterra-partnership](http://www.doc.govt.nz/about-us/our-partners/our-national-partners/fonterra-partnership) (accessed 23 April 2015).

<sup>58</sup> [www.landandwater.org.nz/Site/default.aspx](http://www.landandwater.org.nz/Site/default.aspx) (accessed 23 April 2015).

2. Digitised spatial data are only available for the current ecological management units.
3. A high level of expertise, appropriate training and ongoing support is required to run the tool.
4. Other tools or models would need to be used to create ecosystem service distribution maps, as this falls outside Zonation's capabilities. These distribution maps could then be fed into Zonation to identify areas of highest ecosystem service value.
5. The effective use of Zonation for ecosystem service mapping and prioritisation would be dependent on an adequate ecosystem classification system, understanding the relationship between the range of ecosystem services and the ecosystem classification, and supporting spatial data for land managed by both DOC and others. Currently, such data do not exist.

If Zonation could be adapted for such a purpose, ecosystem service hotspots could be compared with the distribution of conservation and historic value, which could then help to identify optimal areas where projects could be undertaken to achieve both social and conservation goals. DOC has carried out a preliminary investigation into the possibility of considering societal interests in its prioritisation approach by incorporating community involvement as an additional step (John Leathwick, DOC, pers. comm.). This may be explored further in the future.

Interestingly, Whitehead et al. (2014) used Zonation software to quantify the effect of development preferences and social values as part of a spatially explicit conservation prioritisation analysis for the Lower Hunter region in New South Wales, Australia. This was done by simultaneously incorporating social values for conservation (determined using PPGIS), development preferences and modelled distributions of threatened species (to represent biological values for conservation) into Zonation (Whitehead et al. 2014). Their results demonstrate that a landscape prioritisation analysis can be used to develop ecologically defensible and socially acceptable solutions in response to development pressures (Whitehead et al. 2014); and their approach may also have applications to conservation management issues in New Zealand, such as in DOC's consideration of concession and permit applications.

### 5.1.3 SeaSketch

SeaSketch<sup>59</sup> is a web-based mapping tool developed for use in participatory and collaborative marine spatial planning. As process and planning needs differ from place to place, SeaSketch's many functionalities can be modified and adjusted to support a specific planning process. SeaSketch has been developed by the McClintock Lab at the Centre for Marine Assessment and Planning, Marine Science Institute, University of California Santa Barbara, with initial funding and support provided by Esri and DOC. SeaSketch allows anyone with an internet connection to participate in designing management plans for marine areas, regardless of their technical ability. The tool consists of a core functionality (visualisation of geospatial data, a chat functionality to share and discuss spatial designs with peers) that revolves around built-in analytical reports which are instantly generated to reflect how a particular spatial design fares against process objectives. SeaSketch can also be used to collect spatial information from users. Via a built-in capability, SeaSketch project administrators can quickly set up and disseminate web-based surveys that gather georeferenced information from the target group (closed groups or the public).

SeaSketch has been developed around the concept of GeoDesign. GeoDesign allows its users to draw potential plan elements (e.g. a marine protected area, an area considered for a certain economic development) and obtain immediate feedback on the costs or benefits both to conservation and existing uses. Through iterative drawing and analysis, users can refine their designs and discuss these with other stakeholders. In the future, an optimisation capability could also be developed, whereby users define sets of planning objectives to create optimisation maps.

---

<sup>59</sup> <http://mcclintock.msi.ucsb.edu/projects/seasketch> and [www.seasketch.org](http://www.seasketch.org) (accessed 20 August 2013).

SeaSketch could be used to crowd-source the perceived spatial distribution of various ecosystem services and their values, and to take ecosystem service supply and demand into account in collaborative marine spatial planning.

SeaSketch has been tailored for use in New Zealand, with DOC having a license to use it as a platform for collaborative conservation planning. SeaSketch is being used by the South-East Marine Protection Forum<sup>60</sup> to develop recommendations for marine protected areas along the coastline between Timaru and Waipapa Point<sup>61</sup>; and is also being used to help support the SeaChange-Tai Timu Tai Pari<sup>62</sup>, a collaborative marine spatial planning initiative to inform planning and management of the Hauraki Gulf (see section 6.4.1). SeaSketch could also be used in the future to improve existing datasets. For example, there are plans to use it to collect data from experts for the development of a national estuarine spatial dataset (Helen Curtis, DOC, pers. comm.).

## 6. Case studies

In this section, we explore the specific data requirements and potential methods that may be required to map the following services or groups of services:

1. Cultural ecosystem services
2. Historic heritage services
3. Māori cultural values
4. Perceived social values of ecosystem services<sup>63</sup>
5. Services provided by indigenous biodiversity that benefit agricultural and horticultural industries
6. Freshwater ecosystem services
7. Marine and estuarine ecosystem services

When viewing these case studies, it is important to recognise that:

- The level of complexity and data intensity associated with mapping varies between different services.
- The availability of spatial data (including its accuracy and resolution) is not the only potentially limiting factor in mapping ecosystem services—it is also necessary to have a certain level of knowledge and understanding of ecological systems and principles, societal values and perceptions, and sometimes ecological economics.
- It is difficult to uncover these complexities without conducting a closer examination of specific services.

At the beginning of each case study, we provide background information about the particular service or group of services to uncover any factors that may need to be considered before mapping these services in the New Zealand context. We take a critical view of each topic area, with particular focus on identifying data, knowledge gaps and limitations—although it should be noted that some topic areas are discussed in greater detail than others, which may influence the

---

<sup>60</sup> [www.south-eastmarine.org.nz](http://www.south-eastmarine.org.nz) (accessed 7 January 2015).

<sup>61</sup> <http://south-eastmarine.org.nz/reports-and-maps> (accessed 13 January 2015).

<sup>62</sup> [www.seachange.org.nz](http://www.seachange.org.nz) (accessed 28 July 2014).

<sup>63</sup> Perceived social values of ecosystem services (including provisioning, supporting, regulating and cultural services) are the 'sociocultural perceptions of human wellbeing derived from nature, measured using social assessments and other non-utilitarian means of capturing their value' (Sherrouse & Semmens 2012). It should be noted that the locations and spatial extents of perceived social values may not equal the true locations and spatial extents of the generation of services and their demand.

number of gaps and limitations identified. At the end of each case study, we summarise gaps and possible research ideas in a box, with gaps ranked as follows, according to the extent to which they could act as a barrier to producing a comprehensive map of services and benefits:

- \*\*\*Necessary—It would be difficult to produce an informative map before this gap is addressed.
- \*\* Important—It is important to address this gap to better inform mapping and/or to improve the level of detail/quality of this.
- \* Optional—Although this service could be mapped at a reasonably detailed level before this gap is addressed (assuming there are no other gaps that are considered to be greater barriers), it would be beneficial to address this gap in the long term.

It should be noted that the gaps identified, the ranks given to gaps, the research ideas and the possible mapping approaches discussed may not be comprehensive and may be subjective. We therefore encourage readers to use the information presented as a starting point for further research and to draw their own conclusions.

## 6.1 Cultural ecosystem services

Cultural ecosystem services are particularly important from a conservation perspective as they represent a strong incentive for ecological restoration and conservation (see section 4.4.7). However, to date they have been poorly addressed in ecosystem services research, particularly with regard to non-marketable services and using spatially explicit methods (Hernández-Morcillo et al. 2013). In their empirical review of cultural ecosystem service indicators in international research, Hernández-Morcillo et al. (2013) found that only 23% of studies were explicitly represented spatially on a map, with recreation and tourism being the most common service categories being mapped. This was despite their conclusions that spatially explicit measures not only contribute to improved indicator quality, enhanced visibility of intangible services, and improved understanding of spatial and temporal dynamics, but also enable relative importance to be identified and allow cultural ecosystem services to be included in spatially explicit trade-off analyses that inform land use planning, management, decision-making and policy. They also emphasised the importance of stakeholder participation, including during the conceptualisation and communication phases, and the value of participatory mapping tools.

In the following sections, we discuss mapping:

- Nature-based recreation and tourism, as this has been most commonly addressed in cultural service mapping
- Identity values, given the importance of New Zealand's indigenous species and natural settings to national identity
- Cultural ecosystem services, with a focus on recent developments made by the UK NEAFO, including the potential of applying the indicators developed as part of this research in New Zealand

At the end of each of these sections, we provide summaries of data gaps and future research directions (Boxes 1–3).

### 6.1.1 Nature-based recreation and tourism

Nature-based recreation forms an integral part of the national culture and identity of New Zealanders. The natural environment is an important 'draw-card' for many international visitors (New Zealand Tourism 2012). For example, in the period 2004–2008, most international visitors to New Zealand (70%) were reported to have participated in nature-based activities; and in 2008, international nature-based tourists were on average more likely to spend more time (24 nights) and money (\$3040) per trip in New Zealand than other international tourists

(21 nights; \$2680) (Ministry of Tourism 2009). In addition, some visitors would not visit certain areas (e.g. West Coast) if they were unable to view and use public conservation land (e.g. Butcher Partners Ltd 2004).

As well as contributing to New Zealand's economy, nature-based recreation also enhances human health and wellbeing. In his recent review on the health and wellbeing benefits of spending time in natural areas, Blaschke (2013) concluded that, overall, international evidence suggests that exposure to natural environments has positive effects on human health and wellbeing. However, Blaschke (2013) also found that there is a lack of studies that distinguish between different types of natural areas and/or green space, such as wilderness areas, scenic reserves, or urban parks and gardens; or that focus on the effects of 'blue spaces', defined as marine, coastal and freshwater areas.

### ***DOC's role in nature-based recreation and tourism***

DOC is a significant provider of nature-based tourism and recreation opportunities in New Zealand (DOC 2011). It uses a set of principles known as the Destination Management Framework (DMF) to guide its management of tourism and recreation opportunities and historic heritage, and to work towards the objectives defined in its recreation outcomes model (see DOC 2011; 2014b, c). As part of this framework, four destination categories were developed to ensure that an optimal mix of facilities is provided across a range of opportunities in a cost-effective way, each of which is managed for a different purpose (DOC 2014b):

1. Icons—places to grow domestic and international tourism
2. Gateway destinations—places to attract new participants to outdoor recreation
3. Local treasures—places to increase local community involvement in recreation
4. Backcountry—places that provide a range of adventure activities for experienced and self-reliant people, and that aim to attract a wider range of visitors

Quantification of the economic, social, and health and wellbeing benefits of recreation and tourism in public conservation areas would highlight the continued need for DOC to maintain these areas. A variety of indicators and methods could be used to map recreation and/or tourism values, including species distributions, scenery, site infrastructure, amenities and documented activity spots, and visitor use. The chosen method will depend on the goals, data availability, and time and resource constraints. Some of these indicators are briefly discussed below, beginning with a more lengthy discussion on visitor use as an indicator for recreation and tourism.

### ***Visitor use as an indicator for recreation and tourism on public conservation land***

A large amount of research has investigated visitor use of public conservation land<sup>64</sup>. In 2011, DOC carried out a review of this research, which highlighted several gaps, including a lack of research on family demand, visitation to conservation areas that do not have national park status, visitation by locals and marginalised people, and participation in water-based activities (Lovelock et al. 2011a, b). The four most frequently researched topics were visitor satisfaction, experience, perceptions and needs; whereas the four least studied areas were visitor benefits, expectations, impacts and strategies. Studies have also investigated the economic impacts of recreation and tourism in public conservation lands and waters (NZTRI 2000, 2002, 2005; Butcher Partners Ltd 2004, 2005, 2006b; DOC 2006; Tisdell 2007; Hunt 2008; Wouters 2011). Recently, DOC commissioned research on the recreation and tourism benefits of conservation investment (Clough 2013). This report suggested the need for new primary research involving stratified visitor surveys that would collect information such as visit length, frequency, expenditure and recreation preferences. Such surveys could also allow the collection of new information on values, perceptions and what benefits visitors gain from visiting conservation areas. This would help to address knowledge gaps currently preventing an extrapolation of services and benefits associated with visitation across public conservation areas.

---

<sup>64</sup> [www.doc.govt.nz/about-doc/role/visitor-statistics-and-research](http://www.doc.govt.nz/about-doc/role/visitor-statistics-and-research) (accessed 28 May 2013).

As an example, we determined the data requirements of a basic GIS-based supply and use model of visitation to public conservation land using existing data. Such a model could help DOC to understand which factors influence visitation rates, such as accessibility, infrastructure and environmental attributes (e.g. mountain or sea views, land cover, species diversity, and species distributions). It could also be used to predict visitation in areas where visitor numbers are unknown. Adamowicz et al. (2011) suggested that a regression model could be used to correlate visitor use data with site accessibility, site infrastructure and amenities, environmental attributes, and potential substitute destinations, depending on model complexity and data availability. The availability of each data type is summarised in Table 8, which illustrates that there is already sufficient information to model visitor use if potential substitute destinations are excluded (see below). It should be noted though that the model discussed does not take into account all factors, such as demographic characteristics or proximity to domestic and international tourism flows.

Each data type included in the model is discussed below:

1. **Visitor use**—Visitor numbers are currently estimated for functional locations (i.e. visitor sites) in AMIS (see section 4.3.1). These estimates are used to inform management and planning; and depending on availability, are based on a combination of various sources,

Table 8. Data requirements and availability for modelling visitor use in New Zealand.

Note: Data requirements are based on Adamowicz et al. (2011) and are dependent on model complexity—i.e. not all data are required to build a simple visitor use model. AMIS, DOC’s Asset Management Information System; DOC, Department of Conservation; LINZ, Land Information New Zealand; MPI, Ministry for Primary Industries; NZTA, New Zealand Transport Agency.

DATA REQUIRED	DATA AVAILABLE
Visitor use	<ul style="list-style-type: none"> <li>• Concessions (Permissions Database; DOC)</li> <li>• Electronic counters (AMIS; DOC)</li> <li>• Hut book entries (AMIS; DOC)</li> <li>• Local knowledge</li> <li>• National Visitor Booking System (DOC)</li> <li>• Other sources may provide additional information for specific activities (e.g. the number of hunting licenses per hunting area granted by DOC is recorded in their Hunting Permit Database)</li> <li>• Surveys</li> </ul>
Site accessibility, infrastructure and amenities	<ul style="list-style-type: none"> <li>• Brabyn &amp; Sutton’s (2013) population-based assessment of the geographical accessibility of outdoor recreation opportunities associated with different types of tracks, routes, campgrounds and huts</li> <li>• Geographic place names, roads, railway lines, airports, ski lifts and other infrastructure (LINZ)</li> <li>• Highways (NZTA)</li> <li>• Marine/coastal facilities (Visitor Solutions Ltd et al. 2012; MPI’s value-mapping projects)</li> <li>• NZ MasterMap™—Points of Interest (Terralink International)</li> <li>• Petrol stations (Koordinates)</li> <li>• Recreation Opportunity Spectrum (Joyce &amp; Sutton 2009; DOC/GNS)</li> <li>• Tracks, huts, campgrounds, freedom camping areas, visitor centres, visitor infrastructure and amenities (AMIS; DOC)</li> <li>• DOC’s Destination Management Framework destination categories (DOC 2011; 2014b, c)</li> <li>• Zenbu (Koordinates)</li> </ul>
Environmental attributes	<ul style="list-style-type: none"> <li>• Land and sea data (LINZ)</li> <li>• New Zealand Landscape Classification (Brabyn n.d.; University of Waikato)</li> <li>• See Tables 2 &amp; 3 for species, land use, land cover and ecosystem characteristic classification data</li> </ul>
Potential substitute destinations	<ul style="list-style-type: none"> <li>• Undeveloped</li> </ul>



including hut book entries, the Permissions Database, the National Visitor Booking System, electronic counters, local knowledge and visitor surveys. There is considerable scope for improvement to these data; and if these estimates were to be used to model visitor use, it is important to consider the following to ensure that they are used appropriately:

- Some of the information held in AMIS is not up to date or comprehensive and should be updated to include other data that DOC holds elsewhere.
  - The process used to estimate visitor numbers varies across the country due to inconsistencies in how data are collected. Consequently, a more robust, transparent and auditable process has been developed, which is in the early stages of implementation (Jeff Dalley, DOC, pers. comm.).
  - There is uncertainty associated with the data collected by electronic counters because these are generally not calibrated to verify their accuracy—for example, visitor count errors can arise from counters being bypassed at some sites; groups of people may be under-counted; track users may be counted twice if they return the same way; and counters cannot differentiate between multiple visits by one user and single visits by multiple users.
  - The National Visitor Booking System excludes private huts and non-bookable accommodation.
  - Although annual numbers of hut book entries are recorded in AMIS, there are gaps in these as not all visitors fill out hut books—and some types of visitors may be more likely to fill out hut books than others.
  - Visitor surveys gather rich information about visitor activities, psychographics and demographics. However, conducting surveys at all sites is both impractical and unaffordable.
  - There are some limitations associated with the Permissions Database (see section 4.3.2).
  - Visitor flows are complex and difficult to model using incomplete data.
  - If these limitations are clearly stated and carefully taken into account in the design of the mapping methodology, visitation estimates offer great potential for demonstrating the benefits people gain from public conservation areas. One possible way of dealing with the uncertainty may be to rank visited sites into a discrete number of categories representing varying degrees (e.g. very low, low, medium, high, very high) of visitation rates, or to aggregate visitor number estimates to an appropriate scale.
- 2. Accessibility**—Visitor use could be influenced by site accessibility. GIS proximity analyses can be used to estimate the distance of a site from roads, railways, airports, population centres, settlements, tracks, amenities and visitor facilities. Accessibility can also be estimated using Joyce & Sutton's (2009) Recreation Opportunity Spectrum (ROS), which classifies New Zealand into urban, rural, frontcountry, backcountry, remote and wilderness categories. More recently, Brabyn & Sutton (2013) conducted a least-cost path analysis using GIS to assess accessibility to outdoor recreation opportunities based on travel time via the quickest route from place of residence.
- 3. Site infrastructure and amenities**—Visitor use could be influenced by site infrastructure. For example, visitors may be more likely to visit areas that have access to shelter, huts or toilets. Spatial information for site infrastructure and amenities is available from a variety of sources, such as DOC's AMIS and LINZ.
- 4. Environmental attributes**—Various environmental attributes may influence a site's attractiveness to visitors. Examples include land use, land cover, landscape features, climate, aesthetic values, species diversity, scenic views, the presence of iconic species, and the presence of pests and weeds. Environmental attribute, ecosystem classification and species distribution data are available from various sources (see Tables 2 & 3). The

New Zealand Landscape Classification, developed by Brabyn (1996a, b) and subsequently updated by Brabyn (2009), could also be useful in a visitor use model. This classifies landscapes according to six landscape components—landform, land cover, infrastructure, dominant land cover, influence of water and water views (Brabyn 2009). Brabyn (n.d.) suggested that this classification could be enhanced by integrating it with public preference studies that use a psychophysical approach to assess landscape quality—and this has since been tested by Brown & Brabyn (2012a) (see section 6.4.1).

5. **Potential substitute destinations**—Adamowicz et al. (2011) suggested that a more complex model could include location and attribute information for alternative destinations that could be chosen by a visitor. This would require all visitor destinations to be classified according to attribute information, including environmental attributes, accessibility, site infrastructure and amenities, and recreation opportunities. Social landscape values could also be considered if these became available in the future (see section 6.4). More data may need to be collected if potential substitute destinations were to be included in a visitor use model, such as the residential locations of visitors to enable the calculation of cost and travel time.

### *Amenities and popular locations for recreational and tourism activities*

If insufficient data are available to build the above (or similar) model, the known locations of recreational and tourism activities could be used as an indicator for recreation and tourism. Allen et al. (2009) and Visitor Solutions Ltd et al. (2012) have developed a variety of indicators to represent such utility values associated with the New Zealand coast (see sections 4.4.2 and 4.4.4). These included locations of coastal facilities, amenities, businesses, clubs and other organisations, and sites known to be popular for recreational and tourism activities. Table 9 provides a list of examples of indicators and potential data sources for various land- and water-based activities, including those used by Allen et al. (2009) and Visitor Solutions Ltd et al. (2012). It should be noted, however, that some of these sources may not necessarily provide an exhaustive list or map of sites; some websites and guidebooks may be mainly catering for tourists as opposed to local visitors; and the digitisation of locations may be time consuming.

Table 9. Examples of indicators and data sources used to map nature-based recreation and tourism in New Zealand. DOC, Department of Conservation; LINZ, Land Information New Zealand; MPI, Ministry for Primary Industries; NIWA, National Institute of Water and Atmospheric Research; NZTA, New Zealand Transport Agency.

SUBCOMPONENT	INDICATOR	SOURCE
Boating	Yacht and boat clubs	<ul style="list-style-type: none"> <li>• <a href="http://www.nzs.com/recreation/yacht-clubs">www.nzs.com/recreation/yacht-clubs</a>*</li> <li>• <a href="http://www.yachtingnz.org.nz">www.yachtingnz.org.nz</a>*†</li> </ul>
	Sea hire companies	<ul style="list-style-type: none"> <li>• Sea Kayak Operators Association of New Zealand*</li> </ul>
	Marinas and harbours where yachts can moor overnight.	<ul style="list-style-type: none"> <li>• Individual marina websites*</li> <li>• NIWA*</li> <li>• <a href="http://www.nzmarinas.com">www.nzmarinas.com</a>*†</li> </ul>
	Boat ramps	<ul style="list-style-type: none"> <li>• LINZ†</li> </ul>
	Emergency beacon registrations and registered commercial vessels	<ul style="list-style-type: none"> <li>• Maritime New Zealand†</li> </ul>
	Boat trailer registrations	<ul style="list-style-type: none"> <li>• NZTA†</li> </ul>
	Charter operator business and boat vessel home port registrations	<ul style="list-style-type: none"> <li>• MPI†</li> </ul>
Diving	Diving sites* and companies	<ul style="list-style-type: none"> <li>• Diving guide books†</li> <li>• New Zealand Underwater Association*†</li> <li>• <a href="http://www.divenewzealand.com">www.divenewzealand.com</a>†</li> <li>• <a href="http://www.newzealandnz.co.nz">www.newzealandnz.co.nz</a>*</li> <li>• <a href="http://www.theboatingmap.co.nz">www.theboatingmap.co.nz</a>†</li> </ul>
General	Locations of interest for sport, recreation and tourism, leisure and travel	<ul style="list-style-type: none"> <li>• <a href="http://maps.aa.co.nz">http://maps.aa.co.nz</a></li> <li>• <a href="http://www.aatravel.co.nz/101">www.aatravel.co.nz/101</a></li> <li>• <a href="http://www.aatravel.co.nz/what-to-see-newzealand/attractions.php">www.aatravel.co.nz/what-to-see-newzealand/attractions.php</a></li> <li>• <a href="http://www.tripadvisor.co.nz">www.tripadvisor.co.nz</a></li> </ul>

*Continued on next page*

Table 9 continued

SUBCOMPONENT	INDICATOR	SOURCE
	Cultural events (e.g. wild foods)	<ul style="list-style-type: none"> <li>• <a href="http://www.eventfinder.co.nz">www.eventfinder.co.nz</a></li> <li>• <a href="http://www.seafood.co.nz/news-and-events/explore-nz-map">www.seafood.co.nz/news-and-events/explore-nz-map</a></li> </ul>
	Businesses	<ul style="list-style-type: none"> <li>• Marine Industry Association<sup>†</sup></li> <li>• <a href="http://www.business.govt.nz/companies">www.business.govt.nz/companies</a></li> <li>• <a href="http://www.critchlow.co.nz/data">www.critchlow.co.nz/data</a></li> <li>• <a href="http://www.doc.govt.nz/parks-and-recreation/guides-and-commercial-tourism-providers">www.doc.govt.nz/parks-and-recreation/guides-and-commercial-tourism-providers</a></li> <li>• <a href="http://www.zenbu.co.nz">www.zenbu.co.nz</a></li> <li>• Yellow Pages<sup>†</sup></li> </ul>
	Recreation in public conservation land	<ul style="list-style-type: none"> <li>• <a href="http://www.doc.govt.nz/parks-and-recreation/activity-finder">www.doc.govt.nz/parks-and-recreation/activity-finder</a></li> </ul>
	Extreme sport spots	<ul style="list-style-type: none"> <li>• <a href="http://www.extremesportsmap.com">www.extremesportsmap.com</a></li> </ul>
	Holiday accommodation and facilities	<ul style="list-style-type: none"> <li>• Business Directory<sup>†</sup></li> <li>• DOC<sup>†</sup></li> <li>• Trade Me holiday homes<sup>†</sup></li> <li>• Yellow Pages<sup>†</sup></li> </ul>
	Infrastructure	<ul style="list-style-type: none"> <li>• DOC<sup>†</sup></li> <li>• LINZ<sup>†</sup></li> </ul>
General (marine)	Coastguard offices and unit locations	<ul style="list-style-type: none"> <li>• New Zealand Coast Guard<sup>†</sup></li> </ul>
	Search and rescue incidents	<ul style="list-style-type: none"> <li>• Search and Rescue Sector</li> </ul>
Historic	Archaeological sites for the 'cultural tourist'	<ul style="list-style-type: none"> <li>• <a href="http://www.nzarchaeology.org*">www.nzarchaeology.org*</a></li> </ul>
	Historic sites	<ul style="list-style-type: none"> <li>• <a href="http://www.mch.govt.nz">www.mch.govt.nz</a></li> <li>• <a href="http://www.nzhistory.net.nz/culture/about-the-memorials-register">www.nzhistory.net.nz/culture/about-the-memorials-register</a></li> <li>• <a href="http://www.nzhistory.net.nz/map/new-zealand-wars-memorial-map#map">www.nzhistory.net.nz/map/new-zealand-wars-memorial-map#map</a></li> </ul>
	Shipwrecks	<ul style="list-style-type: none"> <li>• LINZ<sup>†</sup></li> <li>• <a href="http://www.divenewzealand.com†">www.divenewzealand.com†</a></li> <li>• <a href="http://www.theboatingmap.co.nz†">www.theboatingmap.co.nz†</a></li> </ul>
Identity/sense of place	Popular iconic sites to visit	<ul style="list-style-type: none"> <li>• New Zealand Tourism Board list of scenic highlights; <a href="http://www.newzealand.com*">www.newzealand.com*</a></li> <li>• <a href="http://www.aatravel.co.nz/101*">www.aatravel.co.nz/101*</a></li> </ul>
Land-based coastal activities	Beaches	<ul style="list-style-type: none"> <li>• Guide book on beaches<sup>†</sup></li> <li>• Surf Life Saving New Zealand<sup>†</sup></li> </ul>
Rock climbing	Rock climbing spots	<ul style="list-style-type: none"> <li>• <a href="http://climbz.org.nz">http://climbz.org.nz</a></li> <li>• <a href="http://www.climb.co.nz">www.climb.co.nz</a></li> </ul>
Seafood gathering	Fishing clubs	<ul style="list-style-type: none"> <li>• Individual club websites*</li> <li>• New Zealand Big Game Fishing Council*</li> <li>• New Zealand Sport Fishing Council<sup>†</sup></li> </ul>
	Water quality monitoring sites	<ul style="list-style-type: none"> <li>• Regional council and local authority websites and databases*</li> </ul>
	Seafood gathering spots	<ul style="list-style-type: none"> <li>• Fishing experts*</li> </ul>
	Fishing spots	<ul style="list-style-type: none"> <li>• Fishing guide books<sup>†</sup></li> <li>• <a href="http://nzfishingspots.co.nz">http://nzfishingspots.co.nz</a></li> <li>• <a href="http://www.fishingmag.co.nz/Freshwater-Fishing-Places-New-Zealand.htm">www.fishingmag.co.nz/Freshwater-Fishing-Places-New-Zealand.htm</a></li> <li>• <a href="http://www.fishingnirvana.com/fishing-maps/community">www.fishingnirvana.com/fishing-maps/community</a></li> <li>• <a href="http://www.theboatingmap.co.nz†">www.theboatingmap.co.nz†</a></li> <li>• <a href="http://www.tumonz.co.nz/mapbooks.php?mapbook=fishingpoints">www.tumonz.co.nz/mapbooks.php?mapbook=fishingpoints</a></li> </ul>
Surfing	Surfing spots	<ul style="list-style-type: none"> <li>• Surfing guide books<sup>†</sup></li> </ul>
	Nationally significant surf breaks	<ul style="list-style-type: none"> <li>• New Zealand Coastal Policy Statement<sup>†</sup> (DOC 2010c: 26)</li> </ul>
	Surf Life Saving Clubs	<ul style="list-style-type: none"> <li>• Surf Life Saving New Zealand<sup>†</sup></li> </ul>
Walking	Locations open to recreational access on foot and walking tracks	<ul style="list-style-type: none"> <li>• DOC</li> <li>• <a href="http://wams.org.nz/wams_desktop/index.aspx">http://wams.org.nz/wams_desktop/index.aspx</a></li> </ul>
Wildlife watching	Marine mammal permits	<ul style="list-style-type: none"> <li>• DOC<sup>†</sup></li> </ul>
	Birding operators	<ul style="list-style-type: none"> <li>• <a href="http://www.birdingnz.co.nz/birding-operators">http://www.birdingnz.co.nz/birding-operators</a> (also see Birding New Zealand (2012)'s list of birding operators)</li> </ul>
Windsurfing	Windsurfing spots	<ul style="list-style-type: none"> <li>• Windsurfing New Zealand<sup>†</sup></li> </ul>

\* Used by Allen et al. (2009).

† Used by Visitor Solutions Ltd et al. (2012).

### ***Biodiversity data***

Biodiversity data (e.g. species diversity, distribution and observation data) could also be used to estimate recreation and tourism values if they can be linked to a particular activity. For example, the distributions of large game species could be used as a proxy for the social values associated with recreational hunting (see section 6.4.1); marine species such as coral, whales and dolphins are ‘draw-cards’ in the marine environment; and the diversity of avian species could be used as an indicator for potential bird watching values—although the latter would be based on the assumption that high-diversity areas are favoured by bird watchers.

Bird sighting data could also be mapped and interpreted as areas where humans are able to interact with birdlife. As an example, we mapped recreational bird watching values (see Fig. 8—for illustrative purposes only) by ranking each cell of a national 10-km grid according to the number of species recorded in it using species observation data from the OSNZ Bird Atlas (Robertson et al. 2007)—this rank can be used as a proxy for the value associated with bird watching. To produce a more robust map, other attributes would also need to be included in the ranking process, such as rarity, endemism, endangered species status and the preferences of bird watchers. Although these data may be used to examine national or broad-scale patterns, the 10-km resolution limits its utility for smaller scales.

Figure 8. Recreational bird watching values estimated using the species diversity associated with recorded avian species observations.

Note:

(i) Five value classes were defined using the quantile classification method, where low, moderately low, moderate, moderately high and high equate to 0–13, 13–19, 19–24, 24–32 and 32–95 species, respectively.

(ii) This map does not represent the full value associated with bird watching as it only includes the species diversity component—the total recreational bird watching value includes many factors (e.g. rarity, accessibility, endemism), some of which are subjective, being based on an individual bird watcher’s preferences.

Acknowledgement: Avian species observation data taken from Robertson et al. (2007) and used with permission from the Ornithological Society of New Zealand

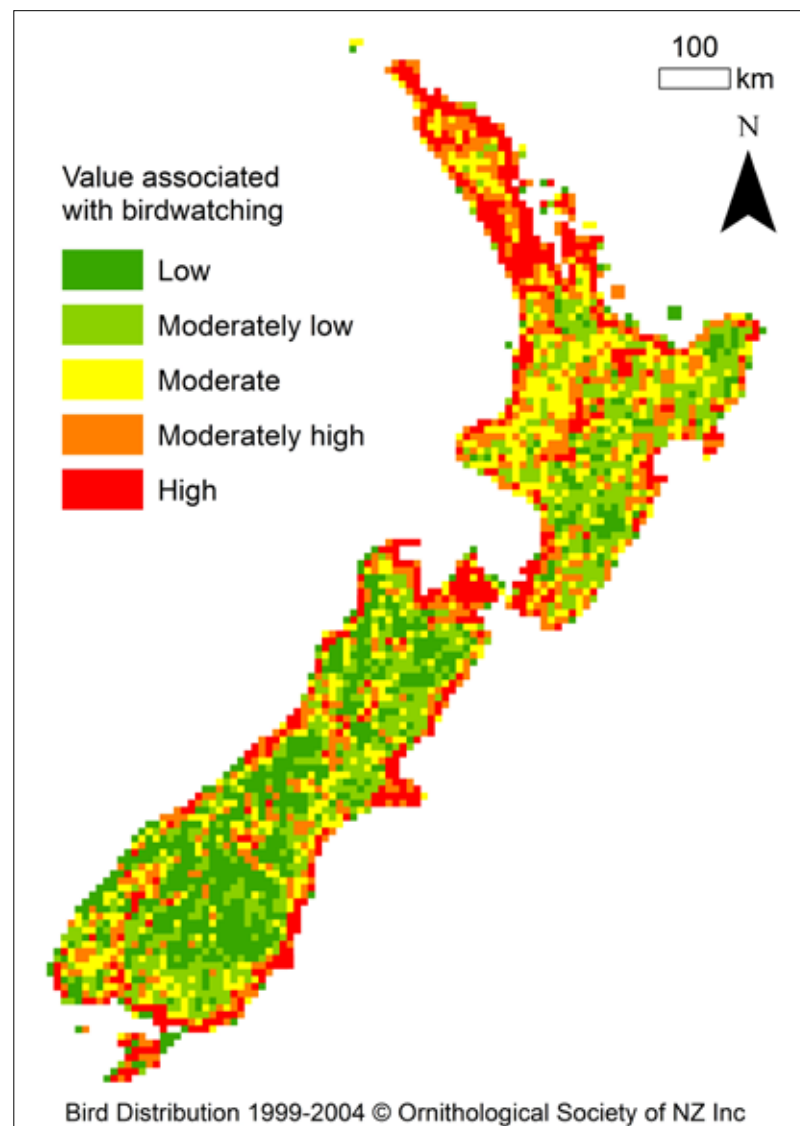

Krisztian Vaz, Auckland University of Technology, is currently investigating the economic and conservation value of bird watching in New Zealand. His study includes a web-based audit to identify and map key birding sites and operators in New Zealand. In addition, he will use Tiritiri Matangi Island and Stewart Island/Rakiura as case studies to investigate the economic impacts of birding for a region and local area, respectively.

### **Scenery**

Scenery can also be used as an indicator to map recreation and tourism values. For example, Chen et al. (2009) used a digital elevation model (DEM) and a scenic spots map in a viewshed<sup>65</sup> analysis and distance analysis to create grid maps of visibility and accessibility, respectively. Map algebra was then used to multiply each of the grid maps by a proportion of annual tourism income, the results of which were summed to yield a spatially explicit total tourism value.

### **Economic values**

Some authors have estimated and/or mapped the economic values associated with recreation and/or tourism values. For example, Costanza et al. (1997, 2014) used a benefit-transfer approach to estimate the average global annual value of ecosystem services, including recreation, for various biomes. The spatial extent of these biomes was estimated using land cover data, allowing Costanza et al. (2014) to produce a global map of annual economic values for ecosystem services. Although no maps of specific ecosystem services were produced, this illustrated that mapping would be possible. In a more recent paper, Ghermandi & Nunes (2013) produced the first global map of coastal recreation values. These were estimated using a global database of primary non-market valuation studies and a spatially explicit meta-analytical framework. The latter took into account the built coastal environment (e.g. accessibility, anthropogenic pressure), natural coastal environment (e.g. marine biodiversity, ecosystem type and protection), geo-climatic factors and socio-political context. It should be noted, however, that the database of primary valuation studies did not include any studies from New Zealand, making the applicability of this study to New Zealand questionable.

#### **BOX 1: MAPPING NATURE-BASED RECREATION AND TOURISM\***

##### **Gaps**

- Information on visit length, frequency and expenditure; visitor preferences, values and perceptions; and what benefits visitors gain from visiting terrestrial, freshwater, estuarine, coastal and marine natural environments and conservation areas.\*\*
- ✓ Filling these gaps would contribute to extrapolating services and benefits associated with visitation to a national level.

##### **Research ideas**

- Create a GIS-based visitor use model, as suggested by Adamowicz et al. (2011). (Note that a preliminary version exists in InVEST.)
- Compile a database of spatially explicit indicators for various types of terrestrial recreation and tourism activities.
- Compile a database of spatially explicit indicators for various types of freshwater recreation and tourism activities.
- Review the accuracy of Visitor Solutions Ltd et al.'s (2012) Geodatabase for Mapping Marine Recreational Use and Value (see section 4.4.4).

\* See p. 50 for box explanation

<sup>65</sup> Wade & Sommer (2006) defined a viewshed as the 'locations visible from one or more specified points or lines. Viewshed maps are useful for such applications as finding well-exposed places for communication towers, or hidden places for parking lots.'

### 6.1.2 Identity values

Natural areas, natural features, historic places and indigenous species contribute to the identity of New Zealanders. The importance of taonga (treasure, prize or possession)<sup>66</sup> species and places has been recognised as vital to the expression of Māori culture and identity (Blaschke 2013); and the importance of iconic species is acknowledged in the New Zealand Biodiversity Strategy<sup>67</sup> (DOC & MfE 2000). DOC also recognises and aims to protect the cultural values associated with these species, and iconic natural features, natural areas and historic places. To this end, DOC's natural heritage outcomes model makes provision for the management of nationally iconic species, nationally iconic natural features and locally treasured natural heritage (DOC 2012b, 2014c). In 2011, questions were included in DOC's National Survey of New Zealanders (Premium Research 2011) to determine which species and natural features New Zealanders consider to be nationally iconic. There were, however, some problems with this survey's methodology that may have affected responses (see Data Supplement 1 for more details). While species such as kiwi (*Apteryx* spp.), ferns, kauri (*Agathis australis*), pōhutukawa (*Metrosideros excelsa*), tūi (*Prosthemadera novaeseelandiae*), kākāpō (*Strigops habroptilus*), kea (*Nestor notabilis*), rimu (*Dacrydium cupressinum*), kōwhai (*Sophora microphylla*) and tuatara (*Sphenodon* spp.) were commonly mentioned, results were not clear-cut for natural features<sup>68</sup>. DOC also commissioned research to identify public expectations for the management of iconic species, and natural features and places (see Mobius Research and Strategy Ltd 2014)<sup>69</sup>, but further work is required to understand how DOC should identify and manage these (DOC 2014a).

Similarly, DOC's historic heritage outcomes model includes historic icons<sup>70</sup> (DOC 2012b, 2014c). DOC's definition of these should be considered before they are used to develop spatial indicators for identity or other cultural values, however. Historic icons are described as the best historic heritage places to tell stories about the identity of New Zealanders, and are considered as destinations to grow tourism and generate economic benefit (DOC 2014c). Therefore, although these icons have identity values associated with them, their distribution alone is not representative of the identity values associated with historic heritage in public conservation areas. The same may be true for locally treasured natural heritage, for which DOC has a focus on conservation partnership initiatives, with the objective being:

*Locally treasured natural heritage is maintained or restored as partnerships.*

#### **Mapping identity values**

The identity values associated with iconic species can be spatially represented using species distributions or species observation data. To illustrate this, we mapped the identity values associated with six nationally iconic birds by ranking observation data from the OSNZ Bird Atlas (Robertson et al. 2007) according to responses from a question about iconic species in DOC's National Survey of New Zealanders (Premium Research 2011) (see Fig. 9). When viewing this, it should be noted that some species may not be acknowledged by the majority of New Zealanders as nationally iconic, even though they may be considered iconic at local scales. For example, although Chatham Islanders may associate the black robin (*Petroica traversi*) with their sense of identity, mainland New Zealanders may not (or do so to a lesser extent), as this species is only found in the Chatham Islands. Therefore, this map is only intended as an example to illustrate what could be done in the future with more robust data—the first step of which would be to conduct further surveys to determine which indigenous species New Zealanders feel contribute to their national identity.

---

<sup>66</sup> [www.maoridictionary.co.nz](http://www.maoridictionary.co.nz) (accessed 1 August 2013).

<sup>67</sup> [www.biodiversity.govt.nz/picture/doing/nzbs/part-one/why.html](http://www.biodiversity.govt.nz/picture/doing/nzbs/part-one/why.html) (accessed 1 August 2013).

<sup>68</sup> [www.doc.govt.nz/about-us/our-role/managing-conservation/natural-heritage-management/identifying-conservation-priorities](http://www.doc.govt.nz/about-us/our-role/managing-conservation/natural-heritage-management/identifying-conservation-priorities) (accessed 5 May 2015).

<sup>69</sup> [www.doc.govt.nz/public-expectations-managing-iconic-species-places](http://www.doc.govt.nz/public-expectations-managing-iconic-species-places) (accessed 24 April 2015).

<sup>70</sup> Historic icons are referred to as icon heritage sites on the DOC website (see [www.doc.govt.nz/our-work/heritage/icon-heritage-sites](http://www.doc.govt.nz/our-work/heritage/icon-heritage-sites); accessed 28 April 2015).

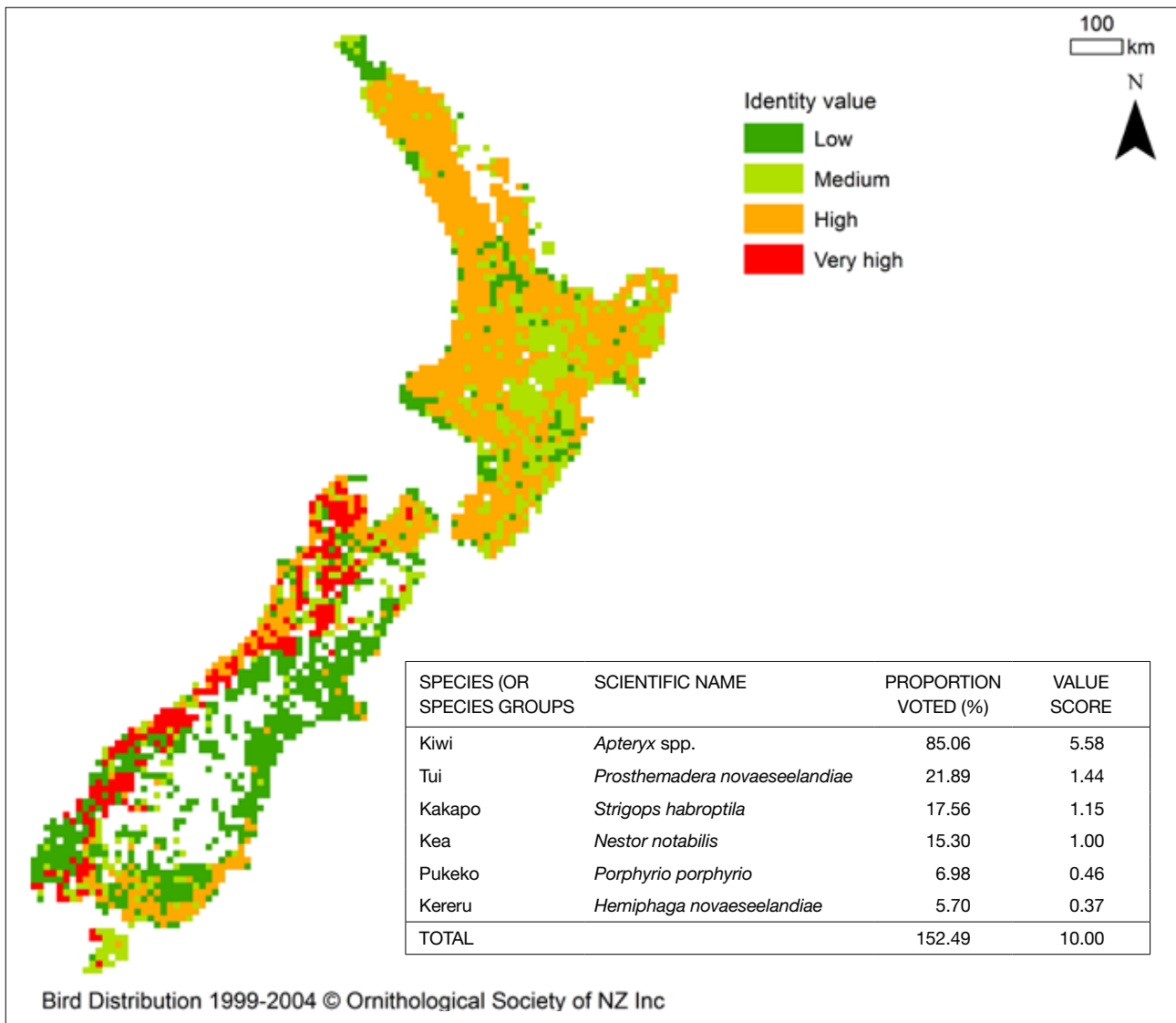

Figure 9. Identity values associated with nationally iconic bird species, estimated by ranking Robertson et al.'s (2007) bird observation data using Premium Research's (2011) survey results. Avian species were only included if at least 5% of survey participants included them in their answer to the following question: 'Which native plants and animals do you consider to be quintessentially kiwi, because they help define who we are as New Zealanders?' The accompanying table shows value scores calculated by converting participant responses (percent voted) into a score out of 10. These scores were assigned to each 10-km grid cell where iconic bird species had been observed. If more than one species had been observed for a grid cell, the value scores for all observed species were summed and then assigned to it.

Acknowledgements: Bird observation data obtained from Robertson et al. (2007) and used with permission from the Ornithological Society of New Zealand. DOC's National Survey of New Zealanders (Premium Research 2011) was used to determine value rankings. **Disclaimer: This map and table were produced as an example and should NOT be used to draw conclusions about identity values associated with nationally iconic bird species in New Zealand because the survey question used to estimate the value rank introduced bias. It should also be noted that identity values are not necessarily absent from areas where these values have not been identified.**

Further survey work may also be necessary to map nationally iconic natural features, natural areas and historic places. Blaschke (2013) recognised the need to carry out surveys on iconic species and natural areas, and recommended that future survey work on identity issues includes surveying New Zealanders' attitudes towards indigenous species and natural areas in relation to identity, and their impact on positive emotions and wellbeing. Table 10 provides a list of examples of existing sources of information that could potentially be used to identify iconic species, natural features, natural areas and historic places in the absence of a comprehensive survey. However, the context in which these data were collected or compiled should be considered, as it may limit their use as indicators of identity values. For example, the New Zealand Plant Conservation Network's Favourite Plant of the Year Competition probably mostly involved plant enthusiasts and so would not be truly representative of all New Zealanders. Another example is the ten iconic coastal

Table 10. Examples of existing information sources that could be used to identify iconic species, natural features, natural areas and historic places. (Note: Some of these sources may be biased—for example, results of the New Zealand Plant Conservation Network’s Favourite Plant Competition may be biased towards the opinion of plant enthusiasts.)

CATEGORY	INFORMATION SOURCE
Iconic species	<ul style="list-style-type: none"> <li>National Survey of New Zealanders (Premium Research 2011)</li> </ul>
Iconic bird species	<ul style="list-style-type: none"> <li>Forest &amp; Bird New Zealand’s Bird of the Year and Seabird of the Year (<a href="http://www.birdoftheyear.org.nz">www.birdoftheyear.org.nz</a>)</li> </ul>
Iconic plant species	<ul style="list-style-type: none"> <li>New Zealand Plant Conservation Network’s Favourite Plant Competition</li> </ul>
Iconic natural features, natural areas and historic places	<ul style="list-style-type: none"> <li>New 7 Wonders of Nature (<a href="http://www.new7wonders.com">www.new7wonders.com</a>)—Milford Sound was one of the 28 Official Finalist Candidates in 2009 in a campaign to find the top 7 wonders of nature in the world</li> <li>UNESCO World Heritage List—Tongariro National Park, New Zealand subantarctic islands and Te Wāhipounamu (South West New Zealand) are internationally recognised as UNESCO World Heritage sites</li> <li>Various guidebooks and websites on tourist destinations in New Zealand—e.g. <a href="http://famouswonders.com/oceania/new-zealand">http://famouswonders.com/oceania/new-zealand</a>; <a href="http://www.newzealand.com/int">www.newzealand.com/int</a></li> </ul>

destinations that have recently been identified by DOC in partnership with Air New Zealand as part of a new marine destination brand called ‘Coastal Gems’<sup>71</sup>. Although the locations of these can be mapped<sup>72</sup>, they could not necessarily be used as an indicator of coastal identity values as these sites were not chosen for this reason but rather with the aim of encouraging more people to experience and enjoy New Zealand’s marine reserve destinations, thereby inspiring them to care more for the marine environment. Such promotion, however, may help to shape human behaviour and so influence identity values.

Accessibility may also be considered when mapping the identity values associated with iconic species, natural features, natural places and historic places. This can be estimated using the Recreation Opportunity Spectrum (Joyce & Sutton 2009). Iconic species, places and features are made more accessible by wildlife centres, where indigenous species can be viewed in captivity, and nature tours. In addition, iconic species are also made more accessible by publically accessible mainland and offshore islands. Location information for some DOC concessions or permits, which are held in its Permissions Database, may provide information on where people are interacting with iconic species and places (e.g. guided activities), or where iconic species are held in captivity, thereby making them more accessible to the public in some cases.

It should be noted that accessibility has many dimensions, including cultural, financial and geographic barriers (Brabyn & Sutton 2013), further adding to the complexity of mapping identity values. In addition, accessibility to iconic species and places does not have to be limited to personal encounters or physical contact. For example, kiwi species are icons of national identity for New Zealanders, even though most will never personally encounter a kiwi in the wild. Rather, various types of media such as television, radio, books and magazines, the internet, and social media can be used to make species like this more accessible to people all over the world. A good example of this is Sirocco the Kākāpō, who has a Facebook page that is run by DOC<sup>73</sup>. People from all over the world ‘like’ Sirocco’s page, including from New Zealand, the United States, Australia, the United Kingdom, Finland, Germany and Canada (DOC intranet, 2013). Interestingly, the kākāpō was recently voted the world’s favourite species<sup>74</sup>, with the most frequently selected reason for voting for this species being that it is threatened and there is a need to protect it.

<sup>71</sup> [www.doc.govt.nz/parks-and-recreation/places-to-visit/coastal-gems](http://www.doc.govt.nz/parks-and-recreation/places-to-visit/coastal-gems) (accessed 6 March 2014).

<sup>72</sup> [www.doc.govt.nz/parks-and-recreation/places-to-visit/coastal-gems-map](http://www.doc.govt.nz/parks-and-recreation/places-to-visit/coastal-gems-map) (accessed 19 January 2015).

<sup>73</sup> <http://intranet/our-work/support-services/communications/communications-toolbox/Communication-services/DOC-website1/Social-media/Using-social-media/sirocco-on-facebook> (accessed 9 April 2013).

<sup>74</sup> [www.arkive.org/worlds-favourite](http://www.arkive.org/worlds-favourite) (accessed 29 May 2013).



**BOX 2: MAPPING IDENTITY VALUES\***

**Gaps**

*Iconic features and places:*

- Comprehensive list and accompanying spatial definitions for locally, regionally and nationally significant natural features, natural places and historic places.\*\*\*

*Iconic species (using species observation and/or distribution data as a proxy for identity values):*

- Comprehensive understanding of which indigenous species are locally, regionally and nationally significant.\*\*\*

**Research ideas**

- Compile a list and develop accompanying spatial definitions for locally, regionally and nationally significant natural features, natural places and historic places.
- Develop a single database containing species observation locations from the main available sources.
- Compile a database of spatially explicit indicators for various types of freshwater recreation and tourism activities.
- Conduct surveys to determine which terrestrial, freshwater, estuarine and marine species are considered to be iconic species at local, regional and national scales. Use the results to conduct an overlay analysis of species observations and/or distributions, ranking species according to their level of popularity in the survey. (Other variables, such as accessibility, may also be included.)

\* See p. 50 for box explanation

### 6.1.3 Cultural ecosystem services

As part of the UK NEAFO, Church et al. (2014) developed a new conceptual framework for understanding cultural ecosystem services<sup>75</sup> that aimed to help address some of the challenges mentioned in section 4.4.7. This framework followed a place-based approach, which explored the idea of culture in a geographical context, recognising that cultural ecosystem services encompass not only the environmental spaces within which people interact with ecosystems, but also the cultural practices that define these interactions (Church et al. 2014). It defined four components of cultural ecosystem services—environmental spaces, cultural practices, cultural ecosystem benefits and cultural values—each of which influences and is influenced by all the other components (see Table 11). Using this framework and accepted international criteria for the

Table 11. Church et al. (2014) defined four components of cultural ecosystem services in their place-based conceptual framework for understanding these services; and developed indicators that related mainly to environmental spaces where cultural practices occur and where cultural benefits are enjoyed (refer to asterisked components and Table 12).

COMPONENT	DEFINITION	TYPES
Environmental spaces*	<i>Places, localities, landscapes and seascapes in which people interact with each other and the natural environment</i>	<ul style="list-style-type: none"> <li>• Gardens/parks</li> <li>• Farmland/woodland</li> <li>• Beaches/seascapes</li> <li>• Rivers/streams</li> </ul>
Cultural practices*	<i>Expressive, symbolic, embodied and interpretive interactions between people and the natural environment</i>	<ul style="list-style-type: none"> <li>• Playing/exercising</li> <li>• Creating/expressing</li> <li>• Producing/caring</li> <li>• Gathering/consuming</li> </ul>
Cultural ecosystem benefits*	<i>Dimensions of human well-being that can be associated with and that derive from these interactions between people and the natural environment</i>	<ul style="list-style-type: none"> <li>• Identities (e.g. sense of place)</li> <li>• Experiences (e.g. inspiration)</li> <li>• Capabilities (e.g. knowledge)</li> </ul>
Cultural values	<i>Collective norms and expectations that influence how ecosystems accrue meaning and significance for people</i>	

<sup>75</sup> Church et al. (2014) modified the MA (2005) definition for cultural ecosystem services from ‘non-material benefits people obtain from ecosystems’ to ‘ecosystems’ contribution to the non-material benefits (e.g. capabilities and experiences) that arise from human–ecosystem relationships’. This new definition recognises the difference between services and benefits; does not project the property of intangibility onto the service itself; and recognises that culture adheres to material objects (in an ecosystem services context, these include ecosystems, landscapes and components of ecosystems), which is commonly accepted in the fields of social sciences and the humanities (e.g. anthropology, archaeology), where the concepts of ‘material culture’ and ‘cultural materialism’ have been developed (Church et al. 2014).

development of robust indicators<sup>76</sup>, Church et al. (2014) compiled a list of possible indicators and developed four types of spatially explicit quantitative indicators—supply, accessibility, demand and quality. Since a place-based approach was followed, these indicators related mainly to environmental spaces where cultural practices occur and where cultural benefits are enjoyed (see Table 11). In Table 12, we provide examples of readily available data that could be used to develop these four types of indicators in New Zealand and the limitations that may need to be considered.

These quantitative indicators can be used to develop a standardised approach for large-scale analysis and comparison of cultural ecosystem services across temporal and spatial scales. However, a range of other approaches derived from the social sciences, and arts and humanities (e.g. surveys, and participatory, interpretive<sup>77</sup>, deliberative<sup>78</sup> and dialogue-based research approaches), which yield both detailed and geo-located quantitative and qualitative data, is needed to develop a comprehensive understanding of cultural services, particularly for analysis at smaller spatial scales (Church et al. 2014). As a result, Church et al. (2014) developed several case studies exploring the use of participatory mapping methods for mapping cultural services. (Note: PPGIS is discussed in the context of social values for ecosystem services in section 6.4.1; and an example of marine participatory mapping is given in section 6.7). Furthermore, the authors noted that while social science techniques often aim to generalise and systematise knowledge about human relationships with ecosystems, landscapes and locations, the arts and humanities embrace ambiguity, variety, irreducible difference, contingency and unpredictability, and the uncertainty associated with human experience. They concluded, therefore, that using a combination of these approaches to consider these attributes will increase understanding of the values and benefits attached to ecosystems, landscapes and locations (Church et al. 2014).

### BOX 3: MAPPING CULTURAL ECOSYSTEM SERVICES USING FINDINGS FROM THE UK NEAFO\*

#### Gaps

- A comprehensive understanding of a wide array of cultural services that extends beyond recreation and tourism.\*\*
- A conceptual framework and guidelines for using multi-disciplinary spatially explicit research techniques for investigating cultural services in New Zealand at:
  - Large scales (e.g. national, regional), using a standardised approach that allows comparison across time and space\*\*
  - Local scales (e.g. landscape-level), using participatory, interpretive, deliberative and dialogue-based research approaches that help to understand the ambiguous, unpredictable and unique attributes of cultural ecosystem services that could not be addressed at larger scales.\*\*

#### Research ideas

- Compile a list and develop accompanying spatial definitions for locally, regionally and nationally significant natural features, natural places and historic places.
- Compile a comprehensive list of possible spatially explicit indicators for cultural ecosystem services in New Zealand that would use readily available data and meet accepted criteria for the development of robust indicators.

#### UK NEAFO's four types of quantitative indicators:

- Supply: Investigate which factors, in addition to extent, influence the supply of environmental spaces in New Zealand (e.g. spatial pattern).
- Accessibility: Investigate which factors, in addition to geographic proximity, determine accessibility to different types of environmental spaces for different groups of New Zealanders (stratified by socio-economic and demographic variables) (e.g. financial and cultural barriers).
- Demand: Investigate demand for different types of practices in different types of environmental spaces by different groups of New Zealanders.
- Quality: Investigate which factors are important to different groups of New Zealanders for different practices and environmental spaces in terms of environmental quality. Once this has been done, develop suitable indicators for each factor.

\* See p. 50 for box explanation

<sup>76</sup> Church et al.'s (2014: 21) criteria were based on a number of previous studies.

<sup>77</sup> In the context of ecosystem services, interpretive approaches help to understand the narratives of natural places and what they mean to individuals, communities and cultures (Kenter 2014). Examples include ethnographies, genealogies, landscape character descriptions, storytelling, interviews, participant observations and textual analysis of media outputs (Kenter 2014). GIS-based participatory mapping methods can also be interpretive (Kenter 2014).

<sup>78</sup> Deliberative approaches follow a democratic process (Kenter 2014) by allowing a group of actors to exchange information and critically examine an issue to come to an agreement that will inform a decision (Gauvin 2009). Examples include discussion groups, opinion polls, citizens' juries and interviews (Kenter 2014). GIS-based participatory mapping methods can also be deliberative (Kenter 2014).

Table 12. The four types of cultural service quantitative indicators developed by Church et al. (2014) with examples of measures or data that could be used in New Zealand. Note that accessibility and demand indicators can be stratified according to socioeconomic (e.g. education, income) and demographic (e.g. adults versus children) variables.

INDICATOR	MEASURES (UK)	EXAMPLES OF MEASURES/DATA THAT COULD BE USED FOR NEW ZEALAND	EXAMPLES OF POSSIBLE LIMITATIONS
<b>Supply</b>	Percentage cover and area-based estimates	<p>Percentage cover for the following, summarised according to spatial units (e.g. census meshblocks or regional council boundaries, Statistics New Zealand; or fishnet grid cells):</p> <ul style="list-style-type: none"> <li>• Indigenous land cover types (e.g. indigenous forest, estuaries) based on Land Cover Database (Steve Thompson &amp; Partners n.d.; Landcare Research).</li> <li>• Protected area types (e.g. national parks, conservation covenants, marine reserves) as defined in the National Property and Land Information System (NaPALIS; Department of Conservation – DOC/Land Information New Zealand – LINZ).</li> <li>• Largely natural urban parks and gardens (regional councils).</li> </ul>	Extent alone is unlikely to capture cultural ecosystem services—other significant factors may include the pattern, shape and form of cover types, their relationship with other landscape components, local contexts, and personal perspectives (Church et al. 2014).
<b>Accessibility to various types of environmental spaces</b>	Geographic proximity	<ul style="list-style-type: none"> <li>• Recreation Opportunity Spectrum (Joyce &amp; Sutton 2009; DOC/GNS).</li> <li>• Brabyn &amp; Sutton's (2013) population based assessment of the geographical accessibility of outdoor recreation opportunities associated with different types of tracks, routes, campgrounds and huts.</li> <li>• Proximity from geographic centres of census meshblocks (Statistics New Zealand) to various types of land cover (Land Cover Database; Landcare Research), protected areas (NaPALIS; DOC/LINZ), and largely natural urban parks and gardens (regional councils).</li> <li>• Proximity from country of origin to</li> <li>• national parks (NaPALIS; DOC/LINZ) for</li> <li>• international tourists</li> </ul>	<p>Geographic proximity does not capture all dimensions of accessibility. Examples of other dimensions are cultural and financial barriers (Brabyn &amp; Sutton 2013). In addition, various types of media (e.g. websites, books, television) may make some environmental spaces accessible without visitation.</p> <p>Other limitations will depend on the method used. For example, if straight-line distances from geographic centres of meshblocks to the nearest boundary of destinations are used, more accurate results may be achieved when using (if available): (i) road and track networks rather than straight line distances; (ii) entrance locations for parks and places rather than nearest boundary; and (iii) better resolution origin data (e.g. address or city rather than census meshblocks).</p>
<b>Demand for certain types of environmental spaces or cultural practices associated with them</b>	A Bayesian belief network was produced to show the probability of an individual visiting an environmental space and engaging in cultural practices there, based on data from the Monitor of Engagement in the Natural Environment (MENE) questionnaire*	<p>DOC's annual National Survey of New Zealanders† collects information on visitation to parks and places administered by DOC. Survey participants are asked to identify (i) the parks and places (including historic places) they have visited in the previous 12 months using a printed map and checklist; (ii) the park or place they visited most recently; (iii) the activities undertaken during their most recent visit using a checklist of recreational activities; (iv) the type of visitor facilities used in the last 3 years (e.g. hut, campground, great walk); and (v) the region where they live.</p> <p>Although there are other surveys that investigate visitation, travel, activities and purpose of travel (e.g. by Tourism New Zealand; Ministry of Business, Innovation and Employment; Ministry of Transport), these may not collect sufficient detail for nature-based activities and practices, and spatial data.</p>	Currently, most data on demand for particular places and practices relate to recreation and tourism on land. In the future, a survey such as DOC's National Survey of New Zealanders could be tailored to gain more detailed information on activities or practices (including non-recreational) undertaken in particular localities (including offshore marine protected areas). More detailed spatial data could also be collected for origins and destinations if a web-based participatory mapping application was used. There may, however, be confidentiality constraints relating to participant addresses, and this may exclude participants who are not computer-savvy.

Continued on next page

Table 12 continued

INDICATOR	MEASURES (UK)	EXAMPLES OF MEASURES/DATA THAT COULD BE USED FOR NEW ZEALAND	EXAMPLES OF POSSIBLE LIMITATIONS
<b>Quality</b>			Church et al.'s (2014) secondary quality indicators (except for safety) were based on van Herzele & Wiedemann (2003) characterisation of the attractiveness of green spaces. It should be noted, however, that factors of importance to quality may vary by type of practice, type of environmental space, location, and socioeconomic, cultural and demographic variables. Therefore, further research may need to be conducted investigating which factors New Zealanders consider to be of importance to quality for different types of practices and environmental spaces, and how this is influenced by socioeconomic, cultural and demographic variables. Even when this has been done, it should still be recognised that quality may be highly subjective to individuals, making it difficult to characterise.
Secondary indicators:			
• Space	• Area	Size of conservation area (NaPALIS; DOC/LINZ) or parks (including urban parks and gardens, regional councils)	
• Nature	• Percentage cover	<ul style="list-style-type: none"> <li>• Percentage indigenous cover (Land Cover Database; Landcare Research) in conservation area, park and gardens</li> <li>• Species occurrence (e.g. Ornithological Society of New Zealand Bird Atlas (Robertson et al. 2007) can be used to determine the number of avian species observed within a spatial unit)</li> </ul>	
• Culture/history	• Density of significant sites	• Density of significant sites (see Table 9 for examples of possible data sources)	
• Quietness	• Defra noise maps	• Few data exist on the geographic distribution and levels of noise exposure in New Zealand (McCallum-Clark et al. 2006: appendix 3).	
• Facilities	• Number of facilities	• Number of facilities (see Tables 8 & 9 for examples of possible data sources)	
• Safety	• Density of reported crimes	• Density of reported crimes (New Zealand Police)	

\* See [www.gov.uk/government/collections/monitor-of-engagement-with-the-natural-environment-survey-purpose-and-results](http://www.gov.uk/government/collections/monitor-of-engagement-with-the-natural-environment-survey-purpose-and-results) (accessed 17 December 2014).

† See [www.doc.govt.nz/about-doc/role/visitor-statistics-and-research/survey-of-new-zealanders](http://www.doc.govt.nz/about-doc/role/visitor-statistics-and-research/survey-of-new-zealanders) (accessed 18 December 2014).

## 6.2 Historic heritage services

Conserving New Zealand's historic heritage is one of DOC's core work areas. Historic heritage helps people to understand their past and contributes towards their identity<sup>79</sup>, and a 2008 survey of New Zealanders found that 82% felt that the protection of historic buildings and places was important at a national level (Ministry for Culture and Heritage 2009). There are just over 11 000 recorded archaeological sites on public conservation land, and a large number of other buildings, bridges, structures, tracks and roads that have some heritage values. DOC actively manages<sup>80</sup> approximately 600 historic places (DOC 2010a). Several of these are currently managed and promoted as historic icons<sup>81</sup> (DOC 2013b, 2014c) based on their significance to New Zealand's cultural heritage and identity, their accessibility to visitors, and their visitor experience value. Currently, actively conserved historic places<sup>82</sup> are classified mainly according to their preserved fabric, heritage topic and accessibility. However, the value of a historic site is far more complex than its physical form. Therefore, an improved understanding of historic values should consider connections between historic features and humans and the landscape, associative, spiritual and historic values, and social significance (Grazuleviciute-Vileniske & Matijosaitiene 2010); and the

<sup>79</sup> [www.doc.govt.nz/conservation/historic/managing-heritage/what-is-historic-heritage/historic-heritage-is-important](http://www.doc.govt.nz/conservation/historic/managing-heritage/what-is-historic-heritage/historic-heritage-is-important) (accessed 27 May 2013).

<sup>80</sup> Defined as 'The process of stopping or minimising deterioration of historic structures and sites through a conservation work programme and ongoing maintenance' (DOC 2012a).

<sup>81</sup> Historic icons are referred to as icon heritage sites on the DOC website (see [www.doc.govt.nz/our-work/heritage/icon-heritage-sites](http://www.doc.govt.nz/our-work/heritage/icon-heritage-sites); accessed 28 April 2015).

<sup>82</sup> Defined as 'An area containing one or more archaeological and/or historic sites which has been identified as having heritage significance and which is chosen to have conservation work undertaken on it' (DOC 2012a).

fact that historic values are dynamic and multi-layered over time and space (Brown 2010). These considerations mean that, as for many cultural ecosystem services, mapping historic heritage values is no simple task. The following sections provide an overview of the relationship between historic heritage values and ecosystem services; how historic heritage services can be mapped (including future requirements); and how the mapping process can be aided through advances in landscape research. Data gaps are then summarised in Box 4.

### 6.2.1 Historic heritage values and ecosystem services

Tengberg et al. (2012) suggested that there is a need to integrate the ecosystem services framework with cultural landscape and heritage research that is promoted by conventions such as the European Landscape Convention, the World Heritage Convention and the Intangible Cultural Heritage Convention. These conventions view cultural landscapes, which may be associated with a historic event, activity or person<sup>83</sup>, as the ‘combined works of nature and man’<sup>84</sup>, recognising that they include both natural and cultural components, and wildlife and domestic animals.

Although the development of practical spatially explicit trade-off analysis techniques and tools for investigating different land use scenarios has been a major conceptual advantage of the ecosystem services approach (Schaich et al. 2010; Tengberg et al. 2012), the full range of cultural ecosystem services have rarely been fully accounted for in ecosystem service assessments and trade-off analysis. Therefore, our understanding of cultural services under the ecosystem services framework could be enriched by many decades of interdisciplinary and transdisciplinary research on cultural landscapes and their heritage values (Tengberg et al. 2012), including through the following contributions:

1. Bringing a different perspective to the interactions between humans and nature (Schaich et al. 2010)—Cultural landscape research sees humans as an integral part of landscapes (as opposed to humans as impartial observers, beneficiaries of services or external drivers) (Hermann et al. 2011). Accordingly, landscapes are viewed as socio-ecological systems (Hermann et al. 2011), with the European Landscape Convention defining ‘landscape’ as a zone or area as perceived by local people or visitors, whose visual features and character are the result of the action of natural and/or cultural (i.e. human) factors, thereby recognising evolution through time, and treating natural and cultural landscape components together, not separately<sup>85</sup>.
2. Bringing a historical perspective of how societal changes have affected the structures, functions and expressions of landscapes through time (Tengberg et al. 2012).
3. Introducing new assessment tools that could be used to develop techniques and standards for the accounting of cultural ecosystem services (Schaich et al. 2010).
4. Providing insight that would allow the quantification of human perceptions with regard to landscape change and the linkage of cultural values to certain landscape features in a spatially explicit way (Schaich et al. 2010).

It is important to note, however, that although both research communities are investigating the human dimension of ecosystems and landscapes, and promote a holistic approach, there are conceptual and methodological differences between these two research fields (Schaich et al. 2010). For example, ecosystem services research is mostly grounded in ecology, economics and political sciences, whereas cultural landscape research is grounded in land use science, social sciences, humanities and palaeoecology (Schaich et al. 2010).

The integration of these two research fields may be of particular relevance to agencies such as DOC, which have the dual purpose of conserving both natural and historic heritage.

---

<sup>83</sup> National Park Service, United States ([www.nps.gov/tps/standards/four-treatments/landscape-guidelines/terminology.htm](http://www.nps.gov/tps/standards/four-treatments/landscape-guidelines/terminology.htm); accessed 11 June 2015).

<sup>84</sup> World Heritage Convention Committee (<http://whc.unesco.org/en/culturallandscape/#1>; accessed 11 June 2015).

## 6.2.2 Mapping historic heritage values

Despite its complexity, historic heritage mapping is being used to aid landscape management and spatial planning in many countries. The European Landscape Convention encourages public authorities to adopt policies and measures (including GIS and modern techniques of computerised mapping to identify and evaluate landscapes<sup>86</sup>) at local, regional, national and international levels for the protection, management and planning of landscapes and their heritage values in Europe<sup>87</sup>. It promotes a cross-disciplinary and participatory approach that identifies, describes and assesses the territory as a whole, and links ecological, archaeological, historical, cultural, perceptive and economic approaches by combining several approaches to support the sustainable development of landscapes (Tengberg et al. 2012).

In the following examples of historic heritage mapping, an integrated landscape approach has been used that takes into account multiple values, including historic, environmental, cultural and/or economic values:

- Catalonia has developed landscape catalogues<sup>88</sup> in consultation with experts and the public through interviews, workshops and online opinion polls. These catalogues qualitatively and spatially define aesthetic, ecological, historic, cultural and symbolic values attributed to landscapes by the public.
- The Countryside Council for Wales takes landscape values into account in decision-making using the national information system LANDMAP<sup>89</sup>, in which information (including spatial information) on geological, habitat, visual and sensory, historic, and cultural values are gathered, organised and evaluated.
- In New South Wales, cultural landscape mapping is becoming an integrated part of park management; for example, Brown (2010) mapped cultural (including historic) values by categorising sites (identified through research and community engagement) into landscape use and historic themes.
- In Assisi (Umbria, Italy), Vizzari (2011) used GIS analysis techniques combined with Analytical Hierarchy Process-based Multi-Criteria Evaluation methods to define and quantify spatial indicators that could be used to assess landscape quality, in terms of physical-naturalistic components, historical-cultural components and social-symbolic components. This method first calculated the quality of each landscape element (e.g. historic monument) by multiplying its importance by its integrity score, both of which were determined based on expert knowledge and/or surveys. It then assumed that the landscape potential quality (LQp) of each landscape element (symbolised using a vector format) was a spatial gradient that was inversely proportional to the distance from each landscape element (i.e. the LQp was highest at the element but decreased with increasing distance from it). A kernel density GIS-analysis was used to calculate an LQp raster for each landscape element, and a weighted sum of all LQp raster datasets was then calculated using GIS map algebra to yield the overall LQp raster surface. The weights, whose sum equals one, represented the relative importance of each landscape element in determining the overall LQp.

Historic values are also being mapped for management and planning purposes in New Zealand (e.g. district planning—see Dyanna Jolly Consulting 2009). For example, Ngāi Tahu has included historic values as part of its cultural heritage mapping project<sup>90</sup>. The New Zealand Transport

---

<sup>85</sup> <http://conventions.coe.int/Treaty/en/Reports/Html/176.htm> (accessed 4 June 2014).

<sup>86</sup> <http://conventions.coe.int/Treaty/en/Reports/Html/176.htm> (accessed 12 September 2014).

<sup>87</sup> <http://conventions.coe.int/Treaty/en/Summaries/Html/176.htm> and [www.coe.int/t/dg4/cultureheritage/heritage/Landscape/default\\_en.asp](http://www.coe.int/t/dg4/cultureheritage/heritage/Landscape/default_en.asp) (accessed 28 May 2013).

<sup>88</sup> [www.catpaisatge.net/eng/catalegs.php](http://www.catpaisatge.net/eng/catalegs.php) (accessed 28 May 2013).

<sup>89</sup> <http://landmap.ccw.gov.uk> (accessed 10 June 2013).

<sup>90</sup> [www.ngaitahu.iwi.nz](http://www.ngaitahu.iwi.nz) (accessed 6 May 2013).

Agency (NZTA) is also mapping heritage values in the development both of GIS-based methods for identifying archaeological risks along the state highway network (Cable & Standley 2012; Karolyn Buhring, NZTA, pers. comm.) and their Natural Environment and Cultural Asset Management System (NECAMS), which takes natural value (biodiversity, habitat, water systems, soils), landscape value (views, topography, land use) and heritage value (archaeological, cultural, historic, aesthetic, amenity) into account in road management (Meurk et al. 2012; David Greig & Chris Worts, NZTA, pers. comm.).

DOC is also interested in mapping historic heritage values. Stephenson et al. (2004) carried out a heritage landscape study at Bannockburn, in which they trialled an interdisciplinary spatial analysis method that used the connectivity between superimposed layers of history, including Māori associations, mining, farming, the Clyde dam, recreational uses, and today's urbanisation and viticulture. They investigated the connectivity of the landscape with cultural perceptions, community and land use practices, traditions, and stories over time. However, comprehensive mapping of heritage features and values was not attempted, which perhaps is testimony to the complexity of the task, its labour-intensiveness and the level of detail required to embark on such an activity. It is particularly difficult to capture these complexities at larger scales, where it is necessary to categorise heritage values into typologies, as recently done by Brown (2010). However, PPGIS (see section 6.4.1), which has been trialled in Southland (Oyston & Brown 2011; Brown & Brabyn 2012a, b) and Otago (Brown & Brabyn 2012a, b; Hall et al. 2012), may be an effective method for capturing values across large areas.

To map the historic values associated with historic places that are actively conserved by DOC at a national level, the following requirements need to be met:

- **Develop physical, historical, cultural and visitor typologies**—These will be developed as part of DOC's historic optimisation project, which aims to produce a historic prioritisation management system based on Leathwick et al.'s (2012a) ecosystem optimisation process. Ideally, these typologies should be compatible with an ecosystem services framework/typology, and recognise both utility values (e.g. opportunities for learning and recreation) and non-use values (e.g. bequest and identity values).
- **Assign physical, historical, cultural and visitor typologies to each actively conserved site**—A number of information sources could be used to classify actively conserved sites into these different typologies. These include Environmental Impact Assessments (which require concession applicants to assess the potential impacts a proposed activity within public conservation lands and waters may have on natural, historic, recreational and cultural values<sup>91</sup>), DOC conservation reports (e.g. Cochran 2011, 2012, 2013b), DOC maintenance reports (e.g. Cochran 2013a), archaeological survey reports (e.g. Watson 2010), tenure review/pastoral lease reports and submissions (e.g. Dennis 1998), and DOC Historic Heritage Assessments (e.g. Dodd 2006). If using Historic Heritage Assessments, it is important to be aware that:
  - Historic Heritage Assessments have not been completed for all actively conserved sites. However, DOC has recently completed an audit to determine how many actively conserved historic places currently have no associated heritage assessment (Rachael Egerton, DOC, pers. comm.), and those without heritage assessments will be prioritised for heritage assessment completion (Jackie Breen, DOC, pers. comm.).
  - To date, Historic Heritage Assessments have been inconsistent and have not recorded all values, particularly cultural values (Nicola Molloy & Jackie Breen, DOC, pers. comm.). Therefore, a standardised methodology that ideally incorporates at least some of the above typologies needs to be developed.

---

<sup>91</sup> [www.doc.govt.nz/about-doc/concessions-and-permits/concessions/applying-for-a-concession/guide-to-preparing-an-environmental-impact-assessment](http://www.doc.govt.nz/about-doc/concessions-and-permits/concessions/applying-for-a-concession/guide-to-preparing-an-environmental-impact-assessment) (accessed 12 September 2014).

- Following the completion of all Historic Heritage Assessments, typologies may need to be redefined to take into account any new information that surfaces during the process.
- **Develop a methodology for spatially defining historic sites and their values**—The majority of locations of actively conserved historic places are currently defined as points and are matched with AMIS functional locations (DOC 2010b). To successfully map these sites, the following issues may need to be addressed:
  - Some of these sites and/or their values could be better defined as polygons or lines.
  - The reliability of location data for historic sites is variable (Nicola Molloy, DOC, pers. comm.).
- **Develop a methodology for understanding historic and cultural heritage values for individual places, groups of places and landscapes.**
- **Determine the visitation rates at historic sites, and the perceptions and attitudes of New Zealanders and international tourists on the values associated with these sites**—In their review of research on visitors to conservation areas, Lovelock et al. (2011b) concluded that there is a lack of information on the demand for and participation at historic sites managed by DOC, particularly for built heritage.
- **Improve understanding of the ways in which people interact with historic places and the benefits they obtain from these interactions**—Visitation is only one way that people gain benefits from historic sites and their values. Research could be conducted to improve understanding of other ways in which people interact with historic sites (e.g. via educational resources and media), and the benefits and values (e.g. bequest and existence values, education) associated with these interactions.

**BOX 4: MAPPING HISTORIC VALUES AND SERVICES ASSOCIATED WITH ACTIVELY CONSERVED HISTORIC SITES\***

**Gaps**

- Physical, historical, cultural and visitor typologies that could be assigned to sites.\*\*\*
- A systematic methodology for understanding historic and cultural heritage values for individual places, groups of places and landscapes.\*\*

**Research ideas**

- Develop a framework for understanding both ecosystem services and historic heritage services.
- Develop a systematic methodology for understanding the cultural values associated with both natural heritage and historic heritage.
- Research the many ways in which people interact with historic places (including but not limited to visitation) and what benefits they obtain from these interactions.

\* See p. 50 for box explanation

## 6.3 Māori cultural values

In this section, we first provide an overview of the relationship between ecosystem services, Māori values and the Māori world view, including the historical context of how these have been impacted by European settlement (e.g. reduced accessibility to some provisioning ecosystem services). We then build on Harmsworth & Awatere’s (2013) framework for understanding Māori values in the context of ecosystem services, and provide examples of Māori provisioning and cultural services to illustrate this framework. Finally, we discuss mapping Māori ecosystem services and the challenges involved in doing so, and summarise data gaps in Box 5.

### 6.3.1 Māori values and ecosystem services

Although ‘ecosystem services’ is a relatively new term, it is not a new concept. The idea that nature and the environment provide benefits to humans, and that human wellbeing is closely connected to the environment, is ingrained in the traditional Māori world view, values and concepts.



For example, the importance of Waiora (environmental protection) to human wellbeing is reflected in the Māori concept or value of kaitiakitanga, which can be defined as:

*... the responsibilities and kaupapa [plan, strategy, tactics, methods, fundamental principles], passed down from the ancestors, for tangata whenua [people of the land, Māori people] to take care of the places, natural resources and other taonga [valued material and non-material resources, assets or prized possessions] in their rohe [geographical territory of an iwi or hapū], and the mauri [essential life force, spiritual power and distinctiveness that enables each thing to exist in itself] of those places, resources and taonga. (Waddel 1998: viii)*

The concept of Whakapapa also obliges Māori to sustain and maintain the wellbeing of people, communities, natural resources and the environment (Harmsworth & Awatere 2013). Indeed, it is the genealogical connection, relationship or link between humans and ecosystems and all flora and fauna, which goes back many generations to the origin of the universe (Harmsworth & Awatere 2013):

*... beginning with the nothingness, the void, the darkness, to a supreme god (Io-matuakore), then emerging light, through to the creation of the tangible world, the creation of two primeval parents (Ranginui and Papatū-ā-nuku), the birth of their children (the wind, the forest and plants, the sea, the rivers, the animals), through to the creation of mankind. The two primeval parents, once inseparable, had many children, often termed departmental atua or Māori gods ..., each with supernatural powers. In a plan carried out by the children to create light and flourish, the parents were prised apart. The separation of the parents led to Ranginui (the Sky father) forming the sky, resulting in the rain as he continued to weep for his separated wife Papa-tū-ā-nuku (the Earth mother), and Papa-tū-ā-nuku forming the land to provide sustained nourishment for all her children. (Harmsworth & Awatere 2013: 274-275)*

More recently, the importance of ecosystem health to holistic wellbeing has been reflected in a modern health promotion model, which was based on the traditional Māori world view (Ratima 2010) and has been visualised using Te Pae Māhutonga (the Southern Cross star constellation), a Māori cultural icon (Durie 2004; Ratima 2010). Each of the six stars represents an element that contributes to human health, namely Mauriora (cultural identity), Waiora (environmental protection), Te Oranga (participation in society), Toiora (wellbeing and healthy lifestyles), Ngā Manukura (community leadership) and Te Mana Whakahaere (autonomy).

Unfortunately, European colonisation has resulted in the dislocation of whānau, hapū and iwi; the suppression of spiritual beliefs; the confiscation of tribal lands; and the loss of places of learning for Māori (Te Whāiti & Puketapu-Andrews 1997). Consequently, Māori values, identity and knowledge systems have been undermined (Te Whāiti & Puketapu-Andrews 1997; Forster 2012). In addition, the urbanisation of Māori people, driven by economic necessity, has further threatened Māori society, and its communities, language and identity (Keiha & Moon 2008). The displacement of Māori from their traditional lands, and legislation and policies that largely prevent customary harvesting of wildlife and limit access to taonga have meant that many Māori are leading lives that are less connected with nature. However, aspects of Māori culture and customs are being rediscovered and revived to empower and contribute to community development and advancement (Forster 2012).

By combining an ecosystem services framework with traditional Māori knowledge, there is an opportunity to recognise and incorporate this knowledge and Māori values into natural resource management and ecological restoration (e.g. Iwi Ecosystem Services, with Ngāti Raukawa—a project<sup>92</sup> by Massey University, Landcare Research, Te Wānanga-o-Raukawa and Te Rūnanga o Raukawa). This is important, given that holistic decision-making is central to the ecosystem services framework, and so it is critical to consider the values and aspirations of all service

---

<sup>92</sup> [www.mtm.ac.nz/index.php/home/our-project/9-our-project/5-iwi-ecosystem-services-with-ngati-raukawa](http://www.mtm.ac.nz/index.php/home/our-project/9-our-project/5-iwi-ecosystem-services-with-ngati-raukawa) (accessed 24 March 2014).

beneficiaries, including Māori, in decision-making. Cultural assessment tools, which integrate traditional Māori knowledge with science, have already been developed so that Māori cultural values can be considered in decision-making (see Harmsworth & Awatere 2013). Such tools may also provide a means to consider Māori cultural values in ecosystem service assessments in future. For example, Morgan's (2006) Mauri Model provides a framework to link ecosystems with different elements (i.e. social, cultural, environmental and economic) of human wellbeing in such assessments (Harmsworth & Awatere 2013).

The recognition of ecosystem services that are positively impacted by conservation and restoration efforts, particularly where iwi are active participants, could also offer the additional cultural and social benefit of promoting a revival of Māori traditional values and customs. Ngā Hau e Whā o Paparāangi's 20 Year Planting Project<sup>93</sup> is an example of this, whereby native bush in Horokiwi and Newlands is being restored to enable the reintroduction of kiwi, and to allow the whanau and community to harvest native plants for raranga (weaving), rongoā (medicine), Maara kai (traditional cuisine) and mātauranga (knowledge). This project has not only supported the revival and appreciation of Māori culture, but has also brought social benefits to the wider community; for example, retirement villages were given the opportunity to raise seedlings, which were subsequently planted by local school children, encouraging these children to experience a sense of community with the elderly.

### 6.3.2 A framework for understanding Māori values and ecosystem services

Harmsworth & Awatere (2013) discussed Māori cultural values in the context of ecosystem services. They pointed out that while some classifications define ecosystem services as values (e.g. Costanza et al. 1997), others define them as benefits. An example of the latter is the Millennium Ecosystem Assessment (MA 2003), which defined cultural services as the non-material benefits people obtain from ecosystems through spiritual enrichment, cognitive development, reflection, recreation and aesthetic experiences. However, Harmsworth & Awatere (2013) suggested that Māori cultural values encompass both material and non-material benefits, and so presented a Māori ecosystem services framework that uses cultural values to underpin all ecosystem services (i.e. provisioning, regulating, cultural and supporting services) as opposed to only cultural ecosystem services. We have integrated their framework with the framework used in this report to illustrate how Māori values underpin ecosystem services and historic heritage services to contribute to the wellbeing of Māori people, as conceptualised by the Te Pae Māhutonga modern health promotion model (Fig. 10). Examples of Māori provisioning services and Māori cultural services are discussed below in the context of this integrated framework.

#### ***Māori provisioning ecosystem services***

Examples of Māori provisioning ecosystem services include the use of native animal species such as tītī (sooty shearwater, *Puffinus griseus*), toheroa (shellfish, *Paphies ventricosa*) and kererū (New Zealand pigeon, *Hemiphaga novaeseelandiae*) as traditional sources of food (see King et al. (2013) for a discussion on wild foods, including Māori traditional foods); and the use of native plants for food, medicines, crafts, dyes, hunting and fishing, and domestic purposes (Ngā Tipu Whakaoranga database, Landcare Research<sup>94</sup>). However, several pieces of legislation apply to the customary harvesting of native species: the Conservation Act 1987 overarches other legislation administered by DOC<sup>95</sup>; the Wildlife Act 1953 provides protection for native wildlife (mammals, birds, reptiles, amphibians, and a small number of terrestrial invertebrates and marine species) wherever they are found<sup>96</sup> (although section 5 of the Wildlife Act 1953 does allow the Director-

---

<sup>93</sup> <http://www.nhewop.org.nz> (accessed 18 April 2013).

<sup>94</sup> <http://Maoriplantuse.landcareresearch.co.nz> (accessed 31 July 2014).

<sup>95</sup> [www.doc.govt.nz/Documents/getting-involved/nz-conservation-authority-and-boards/nz-conservation-authority/maori-customary-use-summary.pdf](http://www.doc.govt.nz/Documents/getting-involved/nz-conservation-authority-and-boards/nz-conservation-authority/maori-customary-use-summary.pdf) (accessed 28 March 2014).

<sup>96</sup> [www.doc.govt.nz/about-doc/role/legislation/wildlife-act](http://www.doc.govt.nz/about-doc/role/legislation/wildlife-act) (accessed 28 March 2014).

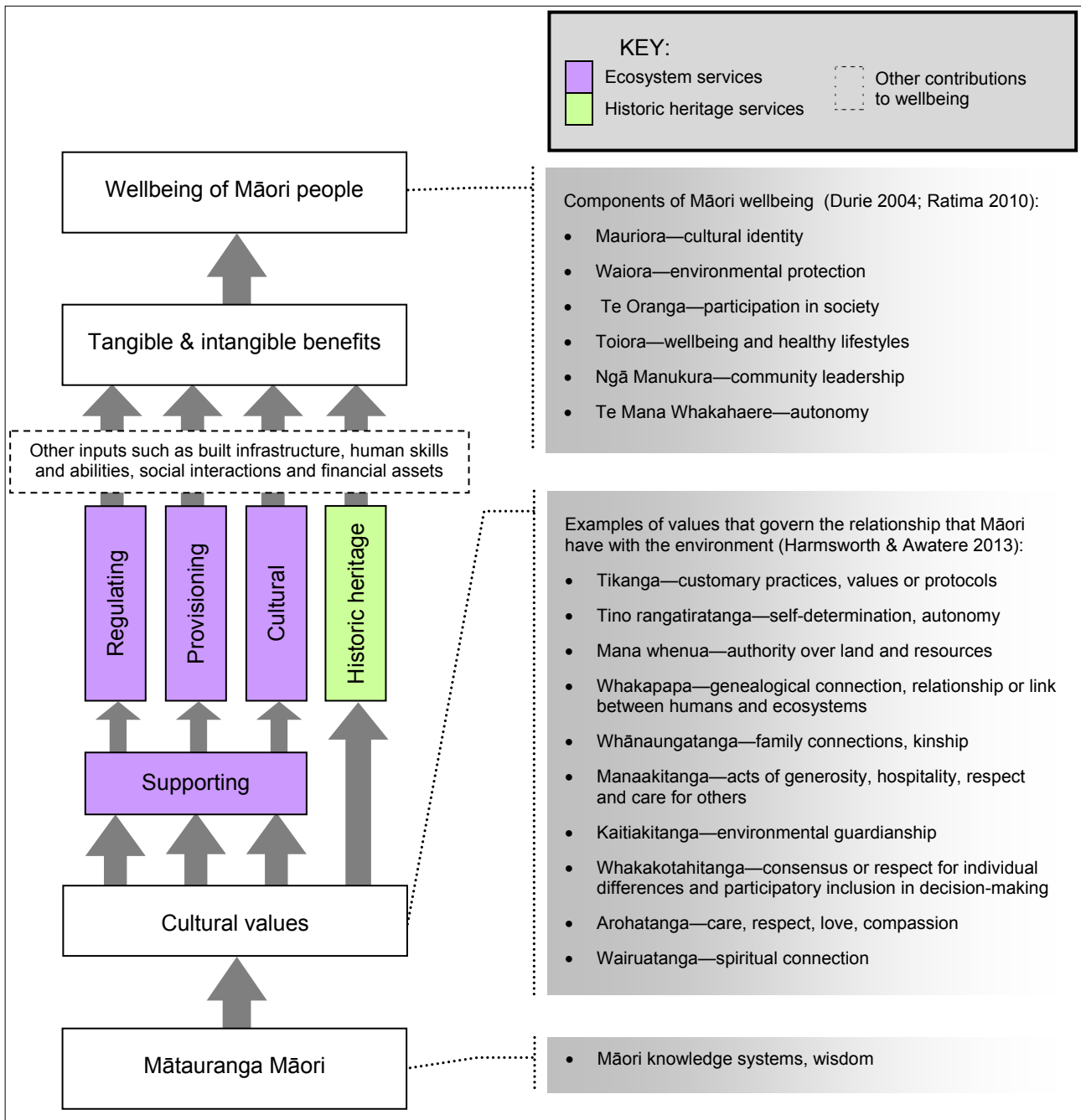

Figure 10. Māori ecosystem services framework based on an integration of the framework used in this report (Fig. 2), Harmsworth & Awatere's (2013) Māori ecosystem services framework and the six components of Māori wellbeing as conceptualised by the Te Pae Māhutonga modern health promotion model (Durie 2004; Ratima 2010). The resulting framework illustrates that Māori values, which are derived from the traditional belief system based on mātauranga Māori (Harmsworth & Awatere 2013), underpin ecosystem services and historic heritage services to contribute to the wellbeing of Māori people.

General to authorise the taking of absolutely or partially protected wildlife for certain purposes); the Marine Mammals Protection Act 1978 provides protection for marine mammals; and the National Parks Act 1980 and Reserves Act 1977 protect plants according to the status of the land on which they are growing<sup>97</sup> (although section 30 of the Conservation Act 1987 makes provision for the allocation of plant material for Māori traditional purposes from land subject to the Act). It should be noted that, by law, these Acts must be interpreted and administered to give effect to

<sup>97</sup> [www.doc.govt.nz/Documents/getting-involved/nz-conservation-authority-and-boards/nz-conservation-authority/maori-customary-use-summary.pdf](http://www.doc.govt.nz/Documents/getting-involved/nz-conservation-authority-and-boards/nz-conservation-authority/maori-customary-use-summary.pdf) (accessed 28 March 2014).

the principles of the Treaty of Waitangi (DOC 2005), some of which include the active protection of Māori interests and the recognition of tribal authority<sup>98</sup>. The following are examples of legally-permissible customary harvesting in New Zealand:

- One of the last remaining large-scale customary uses of native birds in New Zealand is the annual harvesting of tītī on the islands adjacent to Stewart Island/Rakiura (Kitson 2004), which is regulated through the Muttonbird Islands (Titi) Regulations 1978 (Taylor 2000).
- In the north, harvesting of grey-faced petrels (*Pterodroma macroptera*) is legally allowed (via permits) on a limited number of islands for iwi with mana whenua (territorial rights) over those sites (Taylor 2000).
- Customary fishing areas and mātaihai reserves have been established (King et al. 2013).

### ***Māori cultural ecosystem services***

The connection between traditional Māori culture and the natural world goes far beyond utility. This is demonstrated by concepts or values such as whakapapa and kaitiakitanga (see section 6.3.1). In addition, native species feature in traditional stories, proverbs (Ngā Tipu Whakaoranga database, Landcare Research) and, in some cases, are traditional symbols—for example, the koru, which symbolises birth, growth, new hope, strength and peace, is commonly used in Māori tattoos (tā moko) (Spasić 2011). Traditional Māori poetry is also heavily dependent on nature to create imagery and metaphors (Krupa 1996); and the harvesting and traditional uses of culturally significant taonga (treasures) or rangatira (chiefly) species are considered important for maintaining mana (prestige), kaitiaki (environmental responsibilities) and mātauranga (knowledge) (King et al. 2013).

Ngahere (native forests) are not only traditional supermarkets (kai o te ngahere) and medicine cabinets (kāpata rongoā), but are also learning centres (wānanga o te ngahere), schools (kura o te ngahere) and spiritual domains (wairua o te ngahere)<sup>99</sup>. In addition, some cultural activities such as weaving help to maintain social interactions and community connection (W.E. Rawiri, Ngā Hau E Whā O Paparāangi, pers. comm.). The landscape and its natural features are also significant. For example, freshwater resources are believed to connect humans with the spiritual forces operating in the environment (Tipa & Teirney 2006).

Māori place names carry with them memories from historic events, mythology, traditional events, people relationships, and descriptions of land features and resources (Davis et al. 1990). For example, Mt Aspiring is the god called Makahi a Tuterakifanoa in Māori folklore and mythology (Stephenson et al. 2004). Natural features are also significant to an individual's identity. For example, mihimihi (introductory speeches) traditionally involve individuals identifying specific geographic features associated with their tribal area, such as their maunga (mountain), awa (river) and moana (sea), to establish linkages between one another.<sup>100</sup>

### **6.3.3 Mapping Māori ecosystem services**

There is potential for Māori values and ecosystem services to be mapped using GIS—although such a process would require a high level of Māori ownership, participation and leadership.

A large amount of international research has been published on the use of GIS in the context of indigenous knowledge (Harmsworth 1998: bibliography), including to complement traditional methods of storing and transferring knowledge (Harmsworth 1998, 2002; Pacey 2005), to settle historic grievances (Harmsworth 1998), and for land use planning, where it is a legal requirement to take indigenous values into account (Harmsworth 1998). Consequently, there has been a growing interest among Māori to use GIS, and Te Kahui Manu Hokai (Māori GIS

---

<sup>98</sup> [www.doc.govt.nz/Documents/getting-involved/nz-conservation-authority-and-boards/nz-conservation-authority/maori-customary-use-summary.pdf](http://www.doc.govt.nz/Documents/getting-involved/nz-conservation-authority-and-boards/nz-conservation-authority/maori-customary-use-summary.pdf) (accessed 28 March 2014).

<sup>99</sup> [www.landcareresearch.co.nz/\\_data/assets/pdf\\_file/0017/43910/maori\\_values\\_native\\_forest.pdf](http://www.landcareresearch.co.nz/_data/assets/pdf_file/0017/43910/maori_values_native_forest.pdf) (accessed 20 June 2014).

<sup>100</sup> [www.korero.maori.nz/forlearners/protocols/mihimihi.html](http://www.korero.maori.nz/forlearners/protocols/mihimihi.html) (accessed 24 April 2013).

Association) has been established to promote its use for the benefit of iwi Māori<sup>101</sup>. However, mapping Māori values and Māori ecosystem services can be a difficult task due to the sensitivity and confidentiality of this information (Harmsworth 1998). For example, in some cases, Māori stakeholders are unable to disclose location information of culturally significant sites to Ngā Whenua Rāhui<sup>102</sup> operational teams, as this would be considered a violation of tapu (sacredness) (Trevor Lambert, DOC, pers. comm.). Therefore, close consultation with iwi is needed to determine a suitable mapping approach that would avoid violating tapu. It is also important that such consultation includes all iwi concerned, as perspectives may vary across iwi (Trevor Lambert, DOC, pers. comm.).

Despite these difficulties, several initiatives to date have included the mapping of Māori values and/or Māori ecosystem services. For example, Harmsworth (1998) used participatory methods involving several Māori organisations and individuals to develop culturally acceptable methods for recording, organising and making available information on Māori values in a textual and computerised form. Models were produced linking traditional knowledge to GIS and multi-media systems for the benefit of environmental management planning, while protecting confidentiality and intellectual property rights. A suitable GIS database was designed to accommodate the storing of layers with varying degrees of access according to the level of detail, sensitivity and confidentiality—and any information that was too sensitive to be stored in this system was linked to an individual person to show that there was additional information to be obtained.

More recent examples include Ngāi Tahu's<sup>103</sup> cultural heritage mapping project; the Motueka Iwi Resource Management Advisory Komiti's (MIRMAK's) project to design an iwi information system for Te Tau Ihu (Harmsworth et al. 2005); and the Ngā Māramatanga-a-Papa (Iwi Ecosystem Services) project by Massey University, Landcare Research, Te Wānanga-O-Raukawa and Te Rūnanga-o-Raukawa, which involved quantifying and mapping the value of ecosystem services within the rohe of Ngāti Raukawa kit e Tonga (Chrystall et al. 2012; Golubiewski 2012).

The following spatial information could be used to map Māori values and the services they underpin at a national level:

- Māori historic sites and reserves, artefacts, routes, and pā (fortified) sites (see section 6.2.2)
- Geographic distributions of culturally significant indigenous species (this could be collated from a variety of sources—see Table 3)
- Marae locations (Te Puni Kōkiri—Ministry of Māori Development)
- Number of people who consider themselves to be Māori (Statistics New Zealand census data)
- Number of people who speak Māori (Statistics New Zealand census data)

The following aspatial information could be used to support the mapping of Māori cultural values:

- Māori Plant Use Database (Landcare Research)
- Māori place names (Davis et al. 1990)

---

<sup>101</sup> [www.tekahuimanuhokai.org.nz/home](http://www.tekahuimanuhokai.org.nz/home) (accessed 21 May 2014).

<sup>102</sup> Ngā Whenua Rāhui administers two contestable funds: Ngā Whenua Rāhui and Mātauranga Kura Taiao. The former supports the protection of indigenous species on Māori land, whereas the latter supports hapū/iwi initiatives to retain and promote traditional Māori knowledge and its use in biodiversity management. See [www.doc.govt.nz/getting-involved/run-a-project/funding/nga-whenua-rahui](http://www.doc.govt.nz/getting-involved/run-a-project/funding/nga-whenua-rahui) (accessed 21 May 2013).

<sup>103</sup> [www.ngaitahu.iwi.nz](http://www.ngaitahu.iwi.nz) (accessed 6 May 2013).

#### BOX 5: MAPPING MĀORI ECOSYSTEM SERVICES\*

##### Gaps

- Culturally acceptable mapping approach (such as by Harmsworth 1998) that has been developed with iwi consultation, and does not violate tapu and other cultural considerations.\*\*\*

##### Research ideas

- Develop a culturally acceptable approach for mapping Māori cultural values associated with the natural and historic heritage administered by DOC, by consulting with iwi and building on existing approaches such as that of Harmsworth (1998).

\* See p. 50 for box explanation

## 6.4 Perceived social values of ecosystem services

Social values are rarely considered in spatial planning for conservation and environmental management (Brown 2010). This may be because they are often emergent, intangible and subjective, making them difficult to measure. Hebel (1999) noted that each individual person has a group of interconnected social values, which compete against each other in response to circumstances. He also noted that social values are difficult to determine because they are established very early in life and can be unclear even to individuals themselves. However, despite these difficulties, perceived social values of ecosystem services, including those associated with cultural, provisioning, regulating and supporting services (see Fig. 2), should be considered in decision-making, land use planning and management, and policy—particularly where it is important to determine relative values associated with several ecosystem services or other factors (e.g. development goals). It is important to note, however, that a particular decision, policy change or management action may impact stakeholders across different spatial (e.g. local, regional, national) and temporal (e.g. stakeholders who may be impacted by a decision now and in the future) scales; and that impacts may be cumulative and incremental.

Studies of perceptions, values, attitudes and beliefs can be used to provide a more precise understanding of the relevance of ecosystem services for stakeholders, allowing for greater cultural sensitivity and the recognition of trade-offs between different user groups in ecosystem service valuation (Plieninger et al. 2013). PPGIS and other participatory modelling methods, which draw on fields in the social sciences and arts and humanities, can be used to identify and map these values.

Some developments in this field are outlined below. Data gaps and future research directions for each of these are then summarised in Box 6.

### 6.4.1 Mapping perceived social values

A participatory modelling approach has been used by several researchers to map perceived social values of ecosystem services (e.g. Tyrväinen et al. 2007; Raymond et al. 2009; Bryan et al. 2010; Raymond & Brown 2011; Davies 2012; Plieninger et al. 2013). This approach usually involves conducting interviews or workshops where participants are asked to identify areas of value (and value intensity) in relation to an ecosystem service or value typology. These spatially explicit values are then digitised and used in GIS analyses such as overlay operations to summarise the spatial distribution of values. Instead of interviews or workshops, web-based crowdsource mapping applications can also be used. For example, Brown et al. (2012) developed a website using the Google Maps application programming interface (API), where invited participants could drag and drop different ecosystem service markers on the map in locations where they perceived the services were taking place. Similarly, Rebecca Jarvis, a PhD student from the Auckland University of Technology, developed a survey on the value and use of the Hauraki Gulf<sup>104</sup> using a geospatial survey tool developed within SeaSketch<sup>105</sup> (see section 5.1.3)

<sup>104</sup> [www.news.aut.ac.nz/news/2014/march/auckland-and-waikato-people-invited-to-help-plan-hauraki-gulf-future](http://www.news.aut.ac.nz/news/2014/march/auckland-and-waikato-people-invited-to-help-plan-hauraki-gulf-future) and [www.youtube.com/watch?v=P\\_TY3GsT9hw](http://www.youtube.com/watch?v=P_TY3GsT9hw) (accessed 22 May 2014).

<sup>105</sup> [www.seasketch.org](http://www.seasketch.org) (accessed 6 May 2014).

to crowdsource geospatial information on the use and values of specific locations within the Hauraki Gulf, including type of activity, time spent and perceived condition of the environment at each location. The results will help to inform SeaChange<sup>106</sup>, which is a 2 year (2013–2015) collaborative marine spatial planning initiative involving mana whenua, DOC, Auckland Council, Waikato Regional Council, the Hauraki Gulf Forum and MPI. The resulting marine spatial plan will be made available in September 2015 and will inform how the Hauraki Gulf is shared, used and stewarded for future generations.

Another New Zealand example is the pilot studies that were jointly conducted by DOC, the University of Queensland and the University of Waikato in the Otago (Hall et al. 2012) and Southland (Oyston & Brown 2011) regions. Spatial data on public values, experiences and development preferences for conservation land were collected using a PPGIS, and hotspot analyses were then used to identify areas with a high density of values in four topic areas, namely natural heritage, recreation, historic heritage and business enabling. Landscape values identified in these regions were also used by Brown & Brabyn (2012a) to examine the relationships between multiple landscape values and physical landscape character by intersecting landscape components and classes from the New Zealand Landscape Classification with landscape values, and using chi-squared residual analysis and correspondence analysis to identify significant spatial associations. Brown & Brabyn (2012b) also explored methods whereby landscape values obtained through regional participatory mapping can be extrapolated to a national level based on the relationship between these values and physical landscape character categories, as defined by the New Zealand Landscape Classification. Spatial point data for seven selected landscape values (based on a landscape values typology) from Southland and Otago were intersected with the six New Zealand Landscape Classification landscape components (landform, land cover, dominant land cover, water, water view and infrastructure) to develop indices based on the proportion of landscape values occurring within each landscape component. The resulting indices were then applied to landscape components across the whole of New Zealand to extrapolate landscape values identified in the Southland and Otago regions to a national level. It should be noted, however, that Brown & Brabyn's (2012b) goal was to develop a methodology for extrapolating regional landscape values to a national level, rather than to produce a set of robust national value maps. To do the latter, one would need to carry out participatory value mapping projects in more than just two regions and the selected regions should be randomly distributed throughout New Zealand to achieve a representative result. Furthermore, Brown & Brabyn (2012a) urged caution in using interpolated models of landscape values for important land use decisions, and suggested that place-specific, empirical measurement of landscape values should be used, particularly where anthropogenic activities may result in significant changes to landscapes.

Participatory mapping approaches have the following limitations (all of which can be successfully and robustly addressed for the most part through careful planning and methodological design):

1. If web-based surveys are used, there may be a tendency that only the views of computer-savvy participants are encapsulated. Not using web-based surveys may also introduce bias, however, as some people may be more likely to participate in web-based surveys than in other types of surveys.
2. If web-based or mail-based surveys are used, there is a risk that some participants may not fully understand the concepts or values they are being asked to identify. The latter could be minimised by only inviting participants who are known to be suitably knowledgeable. However, this introduces bias, as it only includes a certain type of participant. Alternatively, workshops could be held, whereby participants fill out a survey following an interactive and educational session aimed at increasing their knowledge and understanding of relevant concepts.

---

<sup>106</sup>[www.seachange.org.nz](http://www.seachange.org.nz) (accessed 6 May 2014).

3. Survey response may be poor for various reasons, such as poor design or the perception that a survey is either too difficult or time-consuming to complete.
4. If highly vested or motivated individuals dominate the responses, then the result may be biased.
5. If the study aims to extrapolate values based on biophysical properties, as was the case for Brown & Brabyn (2012b), the limitations of such methodology should be clearly stated. It is particularly important to recognise that some social values may be entirely unique and can therefore not be linked to biophysical properties (Christopher Raymond, Enviroconnect, pers. comm.). It is also important to consider which communities or groups of people are being represented. Therefore, such a survey should ideally include a reasonably detailed description of survey participant characteristics, with an acknowledgment that the values of certain groups were not included or were poorly represented.

An alternative approach to mapping perceived social values is to use indicator data (e.g. land cover, species distributions) that are ranked according to results from a social survey. There are also existing GIS-based tools for mapping and analysing social values. For example, Sherrouse et al. (2011) developed Social Values for Ecosystem Services (SolVES) to assess, map and quantify perceived social values of ecosystem services by deriving a value index from responses to public attitude and preference surveys. Statistical models are then produced describing the relationship between social value maps and explanatory environmental variables (see Appendix 1 for further detail). Such methods have similar limitations to those listed above for participatory mapping methods, however.

Figure 11 demonstrates how social values (in this case recreational hunting values) can be mapped by ranking spatially explicit environmental indicator data by preference scores based on social survey data or expert opinion. In this example, we ranked species distribution raster layers for large game species according to preference scores, which were based on the opinions of a small group of hunters (see Fig. 11B). Other spatially explicit data (e.g. accessibility, land cover) could also be incorporated based on hunter preferences (see Fig. 11A). Since social values are complex and influenced by many factors, a unique value map could be created for each different preference combination (see Fig. 11).

<b>BOX 3: MAPPING SOCIAL VALUES*</b>
<p><b>Gaps</b></p> <ul style="list-style-type: none"> <li>• Comprehensive understanding of social values and preferences in terms of ecosystem services and historic heritage services.***</li> </ul> <p><b>Research ideas</b></p> <p><i>PPGIS:</i></p> <ul style="list-style-type: none"> <li>• Conduct surveys (e.g. web-based mapping surveys) in randomly chosen study areas to establish where people place certain values.</li> <li>• Extrapolate values to a national level using an approach similar to that of Brown &amp; Brabyn (2012b).</li> <li>• Validate the extrapolated values by comparing predicted values with surveyed values at new study areas.</li> </ul> <p><i>Mapping tool/model:</i></p> <ul style="list-style-type: none"> <li>• Conduct a detailed assessment of GIS-based tools such as SolVES to determine which tool would be best suited for application in New Zealand. This could also include an assessment of the potential of tools like RiVAS (currently not fully GIS-compatible) and SeaSketch.</li> <li>• If necessary, further develop or customise the chosen tool to make it suitable for use in New Zealand and the intended purpose.</li> </ul> <p><i>Proxy-based</i></p> <ul style="list-style-type: none"> <li>• Review potential indicators used by other authors to represent specific social values.</li> <li>• Select the most suitable indicators for subcomponents of social values based on data availability, resources (e.g. time, cost), goals and purpose.</li> <li>• Compile a database of spatially explicit indicators.</li> </ul>

\* See p. 50 for box explanation



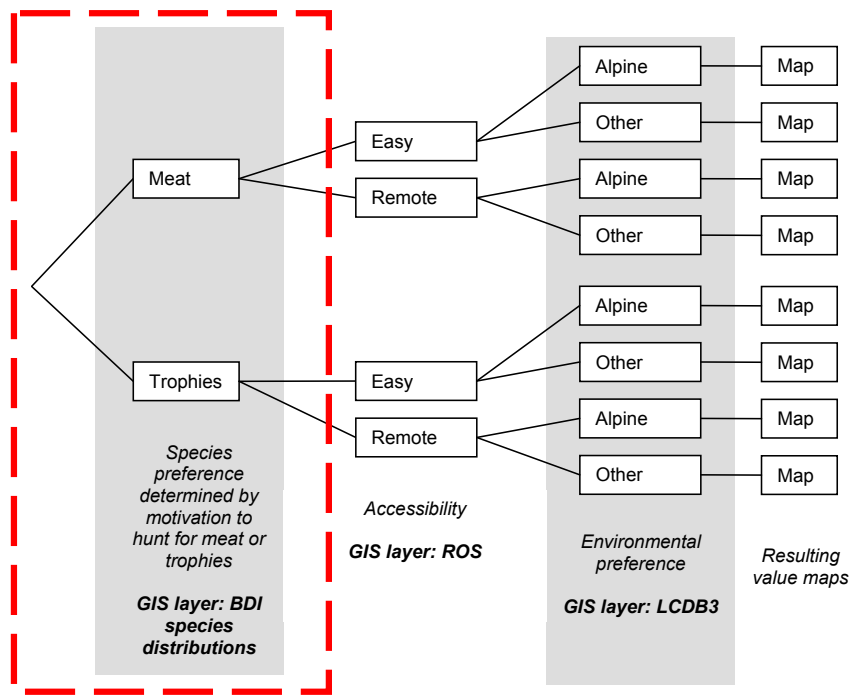

**A**

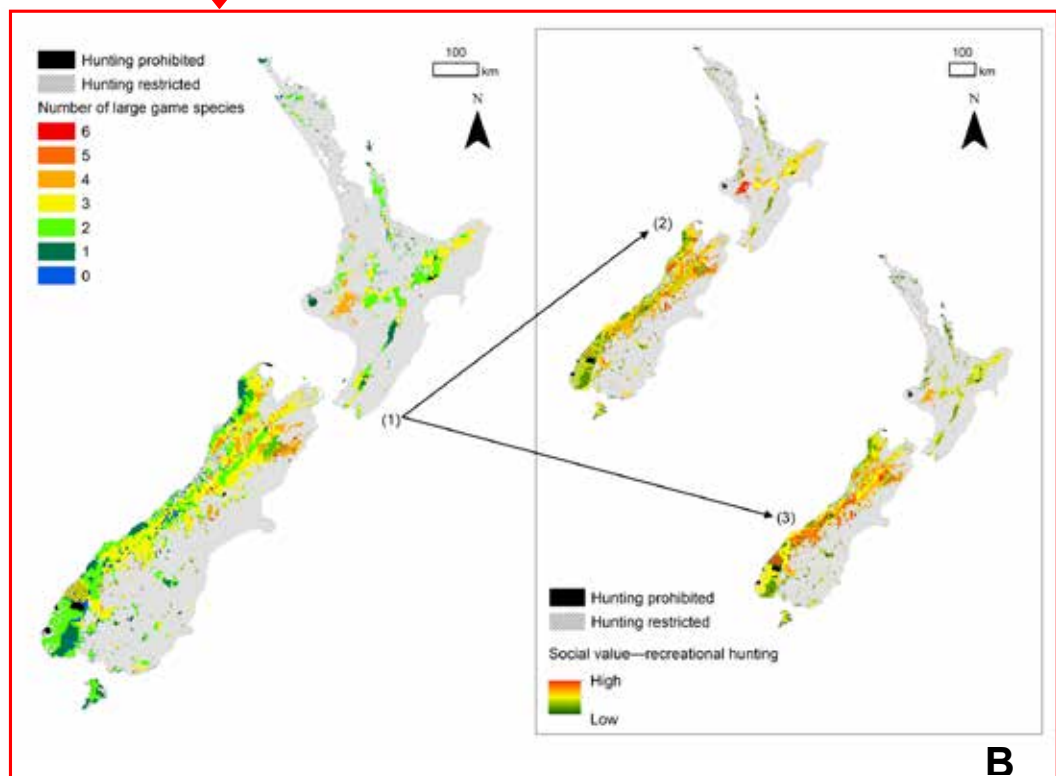

**B**

Figure 11. A possible method for using spatial indicator data to map the social values associated with recreational hunting of large game species in public conservation land.

A. Social values are determined by many factors, which can be represented using various layers of spatial indicator data such as the following, which are ranked (using social survey data or expert opinion) and then combined using map algebra: DOC's Biodiversity Data Inventory (BDI) pest animal distributions, Joyce & Sutton's (2009) Recreation Opportunity Spectrum (ROS), and the Land Cover Database 3 (LCDB3).

B. As an example, we used species distributions as a proxy by first using map algebra to calculate the sum of all presence (value = 1) or absence (value = 0) distribution raster layers associated with each game species (1). We then weighted the resulting raster by preference scores, which were based on the opinions of a small group of hunters. We followed this process for hunters who mainly hunted for meat (2) or for those hunting for trophies (3). This illustrates that there can be many outcomes, depending on many factors, such as the survey participants' preferences, motivations and abilities.

Note: This map is only for illustrative purposes and should not be used to draw real conclusions about recreational hunting values.

## 6.5 Services that benefit agricultural and horticultural industries

Native species provide a range of services that may improve the sustainability of agriculture (Tompkins 2010). Examples include conservation biological control<sup>107</sup>, weed suppression, soil health, erosion control, shelter, greenhouse gas sequestration, wastewater filtration, aesthetic value, marketing opportunities (Tompkins 2010) and pollination. Native species may also be used to help reduce any negative impacts caused by agricultural practices, such as increased pollution and human health risks. For example, Winkworth et al. (2010) showed that native grassland species can be more effective at reducing *Giardia* in agricultural runoff to freshwater ecosystems than exotic pasture grass and weeds, thus reducing a human health risk.

In some cases, present-day agricultural activities benefit from services that were previously provided by ecosystems or species that are no longer present. For example, seabirds are known to enrich the soils of breeding and roosting sites via guano, dead birds and egg material, transferring nutrients from marine to terrestrial environments (Hawke et al. 1999). These breeding colonies were once widespread across New Zealand and extended well inland, but are now largely restricted on the mainland due to introduced predators (Hawke et al. 1999). However, it is possible that nutrients added by former seabird colonies continue to contribute to present-day soil chemistry and fertility, as indicated by several studies to date (Hawke et al. 1999; Hawke 2003; Hawke & Newman 2004). For example, Hawke et al. (1999) found that seabird breeding made significant contributions to present-day nitrogen, phosphorus and cadmium concentrations at two former breeding sites, despite breeding probably having ceased at these sites at least 300 to 700 years ago. This raises the question, if seabirds have made significant contributions to present-day soil fertility, how much longer until these beneficial nutrients are depleted?

The identification, quantification and mapping of services provided to the agricultural and horticultural industries could provide significant opportunities for biodiversity conservation in human-modified landscapes. For example, ecosystem service mapping tools and models (e.g. LUCI—see Appendix 1) can be used to identify land management actions to improve ecosystem services and biodiversity, such as targeted placement of vegetation for erosion control and water quality regulation. Furthermore, if farmers are encouraged to use native plants as an alternative to traditional shelter belt, riparian vegetation and companion plant species, habitat connectivity for native wildlife could be increased. This may, in turn, result in the return of iconic avian species to human-modified landscapes, which could increase interest in conservation and an appreciation of its value among beneficiaries. In addition, the use of native plants in agriculture could also contribute towards restoring Māori cultural connections with nature by providing easier access to plants with traditional uses. For example, a project that is currently being led by Marion Johnson (University of Otago)<sup>108</sup> seeks to do this by enriching agricultural landscapes with multipurpose native plantings.

The following sections consider the role of indigenous species in pest control, pollination, honey production and soil natural capital as examples of the services potentially provided to enhance agricultural and horticultural sustainability. Possible mapping techniques for each of these services are discussed, and Boxes 7–10 summarise data gaps and future research ideas.

### 6.5.1 Pest control

Pest control is very costly to the New Zealand economy. Estimated annual expenditure on pest management by regional councils and central government was about \$41 million and \$337 million (including GST), respectively, in 2008 (Giera & Bell 2009); and on-farm weed and pest control for the private sector (including households) was \$458 million (Giera & Bell 2009). There

---

<sup>107</sup> Defined as modification of the environment or existing practices to reduce the impacts of pests by enhancing their natural enemies (Tompkins 2010).

<sup>108</sup> [www.otago.ac.nz/csaf/research/foodagriculture/otago038853.html](http://www.otago.ac.nz/csaf/research/foodagriculture/otago038853.html) (accessed 6 December 2013).

may be opportunities to reduce these expenditures if the impacts on these pests by natural enemies could be enhanced. This may particularly be the case in many agro-ecosystems, where high levels of disturbance make these environments unfavourable for natural enemies (Landis et al. 2000). It is also increasingly being recognised that landscape and habitat structure has a major influence on insect pests and their natural enemies (Jonsson et al. 2010). Therefore, there may be an opportunity to use habitat management to create suitable ecological infrastructure within agricultural landscapes to provide resources such as food, shelter and alternative prey or hosts (Landis et al. 2000). If the role of indigenous biodiversity in providing pest control services could be identified and quantified, human-modified landscapes could be better managed to enhance this service.

Bianchi et al. (2006) suggested that agricultural intensification, which results in the simplification of landscape composition and a decline in biodiversity, may affect the functioning of pest control, as non-crop habitats provide for a broad spectrum of natural enemies. To test this hypothesis, they conducted a review of existing research and found that natural enemy populations were higher and pest pressure lower in complex versus simple landscapes in 74% and 45% of studies, respectively. This suggests that maintaining pockets of indigenous vegetation in farmlands could enhance biological pest control. Similarly, some studies have suggested that populations of natural enemies may be promoted by increasing the diversity of associated plant and insect species (Hooper et al. 2005). By contrast, more diverse settings have also been reported to lead to larger pest populations by providing key hosts (Hooper et al. 2005). These conflicting results indicate a need for further research before this service could be adequately mapped, but also suggest that habitat structure and complexity (estimated using land cover and land use maps) may be useful indicators of pest control services once understanding has been improved. It should be noted, however, that the relationships between these variables and pest control are likely to be more complex than simple straight-line relationships—for example, some increases in habitat complexity, such as those caused by the introduction of built-up areas, are unlikely to result in improved pest control.

In New Zealand, a 6-year research programme called ‘Biodiversity, ecosystem services and sustainable agriculture’ (see Data Supplement 1), which was led by Stephen Wratten from the Bio-Protection Research Centre at Lincoln University, aimed to develop techniques to enhance the biological control of pests, weeds and diseases. The Greening Waipara project<sup>109</sup>, which was initially part of this programme and is also being led by Stephen Wratten, is also investigating the influence of native plants on pest control (e.g. see Wratten et al. 2006, 2007). Findings suggest that native plant species can be used to suppress weeds, promote natural enemy populations and enhance arthropod diversity in some production landscapes (see Tompkins 2010). As part of another research programme at the Bio-Protection Research Centre, Jonsson et al. (2012) investigated the effect of land use intensity (insecticide application and habitat disturbance), resource availability for parasitoids, habitat diversity and crop cover on host-parasitoid interactions and biological control in agroecosystems in Canterbury. This included quantifying land use patterns using GIS techniques.

Plants and insects are not the only native species that could provide pest control services in production landscapes. The recent ‘Falcons for Grapes’ project in Marlborough showed that threatened New Zealand falcons (*Falco novaeseelandiae*), which are New Zealand’s only remaining endemic bird of prey, are able to provide a pest control service in vineyards (Kross et al. 2012). The abundance of introduced passerine birds decreased significantly when falcons were introduced to vineyards, resulting in a 95% reduction in the number of grapes removed relative to vineyards without falcons. Thus, it was roughly estimated that the presence of falcons could save \$234/ha and \$326/ha per year for the Sauvignon Blanc and Pinot Noir varieties of grapes, respectively. Based on a total area of 16 205 ha and 4777 ha for Sauvignon Blanc and Pinot Noir vineyards, respectively, in

---

<sup>109</sup><http://bioprotection.org.nz/greening-waipara> (accessed 24 September 2013).

2009 (New Zealand Wine Growers 2013), this equates to total potential annual savings of around \$3.8 million and \$1.6 million, respectively, if New Zealand falcons were introduced to all such vineyards. However, introductions may not be possible, desirable or practical from both social, ecological and conservation perspectives, and potential savings may also vary across regions, making it difficult to extrapolate figures from a single region (i.e. Marlborough) to a national level. We mapped this potential pest control service (see Fig. 12) by intersecting 10-km grids where at least one falcon observation was recorded in the OSNZ Bird Atlas (Robertson et al. 2007) with 10-km grids containing viticulture (LUNZ 2011, Landcare Research) to identify the spatial coincidence of falcon observations and viticulture in New Zealand.

#### BOX 7: MAPPING PEST CONTROL SERVICES\*

##### Gaps

- Comprehensive understanding of the relationship between various spatially explicit variables (e.g. habitat complexity, proximity to natural habitat) and pest control.\*\*\*
  - ✓ This would enable a GIS-based model to be developed where the spatial distribution of pest control is predicted using available spatially explicit abiotic and biotic data.

##### Research ideas

- Conduct research to improve understanding of the relationship between various spatially explicit variables (e.g. habitat complexity, proximity to natural habitat, species abundance and diversity) and pest control. Such information could be used to help develop a spatially explicit model predicting the spatial distribution of pest control services provided by certain species or species groups.

\* See p. 50 for box explanation

### 6.5.2 Pollination of food crops

Insect pollination is an extremely important ecosystem service, and has been the focus of many studies and initiatives around the world, including in Africa<sup>110</sup>, Brazil<sup>111</sup>, Europe<sup>112</sup>, North America<sup>113</sup>, Oceania<sup>114</sup> and globally<sup>115</sup>. It supports life-supporting services such as food production and habitat provisioning. For example, three-quarters of global food crops depend at least partly on pollination by animals, usually insects (Tylianakis 2013). Recent declines in honey bee (*Apis mellifera*) populations in many parts of the world have drawn attention to the potential of supplementing them with unmanaged pollinators (Howlett et al. 2009; Rader et al. 2009, 2012, 2013). This is supported by studies that have shown that wild pollinators improve crop yields compared with similar crops that are only pollinated by honey bees (e.g. Garibaldi et al. 2013). Therefore, encouraging pollination by alternative pollinators may offer financial benefits to agriculturalists and horticulturalists, and this could be a particularly attractive option as beekeeping becomes increasingly expensive due to pests and diseases such as varroa (*Varroa destructor*) mites (e.g. MAF 2000; Stevenson et al. 2005).

Pollinators are of particular importance to New Zealand's economy (Newstrom & Robertson 2005; Newstrom-Lloyd 2013), as this is highly dependent on agricultural and horticultural industries. There is growing evidence that New Zealand native insects provide a pollination service to commercial crops (McAlpine & Wotton 2009), but unfortunately few quantitative data are currently available (Rader et al. 2012). Studies do, however, suggest that the contribution of unmanaged species is significant (sometimes greater than 50%) for some crops and that alternative land management practices can be used to increase their effectiveness (Rader et al. 2009, 2012, 2013).

<sup>110</sup> African Pollinator Initiative: [www.arc.agric.za/arc-ppri/Pages/Biosystematics/African-Pollinator-Initiative-\(API\).aspx](http://www.arc.agric.za/arc-ppri/Pages/Biosystematics/African-Pollinator-Initiative-(API).aspx) (accessed 14 September 2014).

<sup>111</sup> Brazilian Pollinators Initiative: [www.webbee.org.br/bpi/ibp\\_english.htm](http://www.webbee.org.br/bpi/ibp_english.htm) (accessed 14 September 2014).

<sup>112</sup> European Pollinator Initiative: <http://europeanpollinatorinitiative.org> (accessed 14 September 2014).

<sup>113</sup> North American Pollinator Protection Campaign: <http://pollinator.org/nappc/index.html> (accessed 14 September 2014).

<sup>114</sup> The Oceania Pollinator Initiative: [www.oceaniapollinator.org/index.asp](http://www.oceaniapollinator.org/index.asp) (accessed 14 September 2014).

<sup>115</sup> International Pollinator Initiative: [www.internationalpollinatorsinitiative.org/jsp/intpollinitiative.jsp](http://www.internationalpollinatorsinitiative.org/jsp/intpollinitiative.jsp); Global Pollination Project [www.internationalpollinatorsinitiative.org/jsp/globalpollproject.jsp](http://www.internationalpollinatorsinitiative.org/jsp/globalpollproject.jsp) (accessed 14 September 2014).

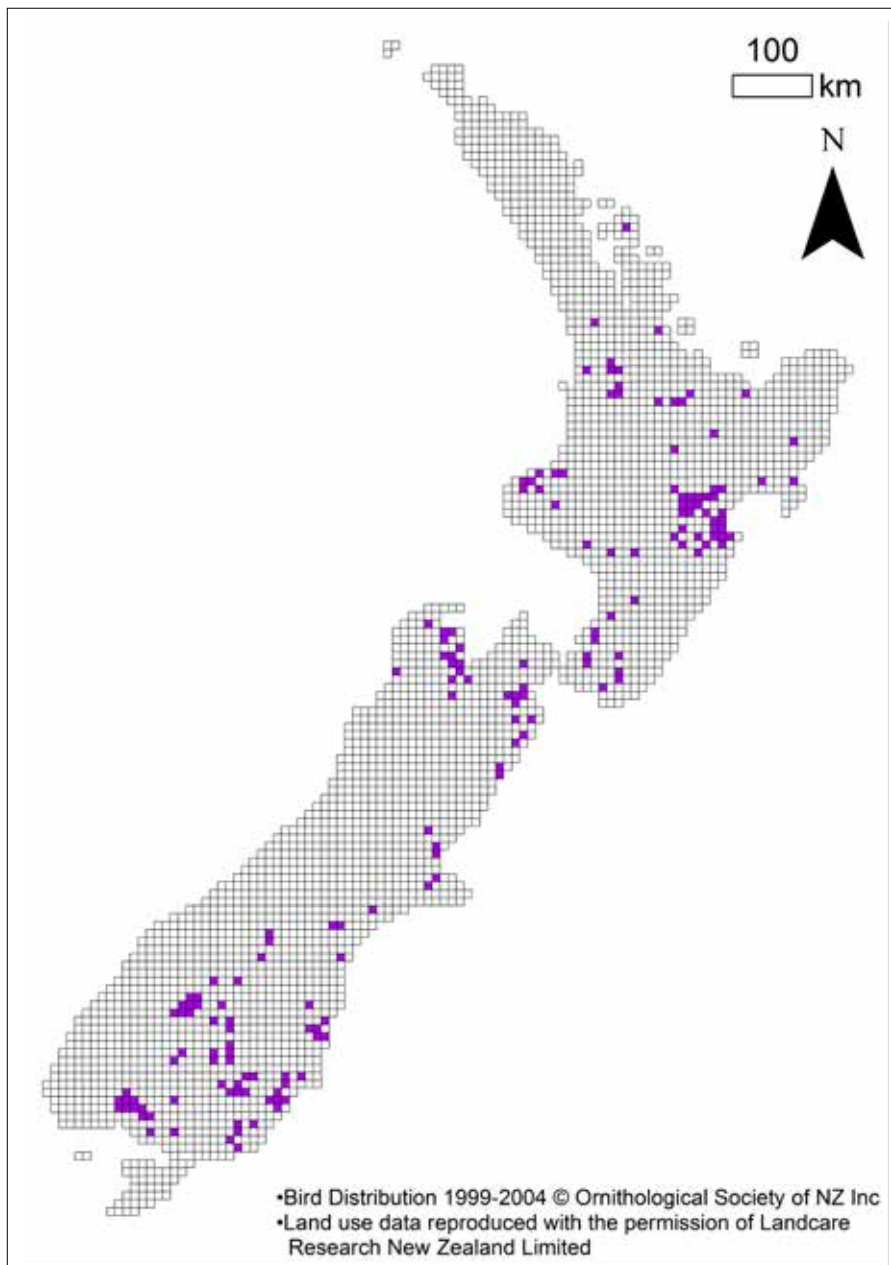

Figure 12. The potential avian pest control service provided by New Zealand falcons (*Falco novaeseelandiae*) in vineyards. We mapped the spatial coincidence of 10-km grids containing at least one New Zealand falcon observation and 10-km grids containing viticulture (purple) as a surrogate for this service.

Acknowledgements: Kross et al.'s (2012) findings provide evidence that New Zealand falcons provide an avian pest control service in vineyards. Falcon observation data were obtained from Robertson et al. (2007) and used with permission from the Ornithological Society of New Zealand. Land use data for viticulture, grape growing and wine production were obtained from Land Use New Zealand (LUNZ 2011) and used with permission from Landcare Research.

Table 13 provides a comparison of data requirements and availability for the mapping of pollination of food crops by native insects in New Zealand. Currently, there are not sufficient data available to produce a robust model. However, Plant and Food Research recently secured funding from MBIE for a project that will help to address these gaps (entitled 'Bee Minus to Bee Plus and Beyond: Higher Yields from Smarter, Growth-focused Pollination Systems') (Brad Howlett, Plant and Food Research, pers. comm.). More specifically, this project aims to quantify the role of individual pollinator species (including unmanaged native and introduced species), and to tailor management practices to benefit pollinators and optimise crop pollination. This will involve assessing the impact of landscape features and spatial context (including surrounding crops and

vegetation) on pollinator abundance and diversity. This relationship will then be used to develop farm management interventions that can be used to maximise the abundance and diversity of beneficial pollinators.

Table 13. Data requirements and availability to map the pollination of food crops by native insects. Requirements are based on Lonsdorf et al. (2011). Note: The amount of information required will depend on model complexity.

DATA REQUIREMENTS	DATA AVAILABLE
Land cover data, including the spatial distribution of farms and crop species	New Zealand Land Cover Database (LCDB; Steve Thompson & Partners n.d.), AgriBase, and other land use and land cover classification databases (see Table 2).
Habitat and resource requirements of pollinator species Availability, distribution and suitability of nesting substrates and floral resources	Some studies have investigated floral resource and nesting requirements of native insects (e.g. Donovan 1980, 2007; Donovan et al. 2010). However, further research is needed to determine the specific resource requirements of unmanaged pollinators (Rader et al. 2012).
Spatial distribution and relative abundance of pollinators	Known location records from various collections have been digitised for 79 taxa from two Diptera families and one Lepidoptera family (insect pollinators distribution maps, Landcare Research). However, this only provides a positive record of occurrence and does not indicate absence from areas where occurrence remains unrecorded.
Foraging and pollen dispersal distances of pollinators (quantitative field estimates, body size, expert opinion)	On a global scale, little is currently known about dispersal distances, particularly for generalist fly species (Rader et al. 2011). In New Zealand, very few studies have addressed this. Rader et al. (2011) found that a diverse array of managed and unmanaged pollinators were able to transport pollen to at least 400 m.
Relative effectiveness and contribution of each insect species as a pollinator for each crop species	To date, only a few studies have attempted to quantify this (e.g. Rader et al. 2009, 2012, 2013; Howlett et al. 2011). Most of these studies have investigated Brassica crops.
Crop yield and value information	This information is available from a variety of sources, including Statistics New Zealand (Agriculture Production Census), Ministry for Primary Industries (e.g. horticulture, arable and farm monitoring reports*) and Fresh Facts† (an annual document published jointly by Plant and Food Research and Horticulture New Zealand—e.g. Aitken & Hewitt 2009).
Number of floral seasons per year and their relative importance to the pollinator	Rader et al. (2012) acknowledged the need to investigate the spatio-temporal interactions in pollinator efficiency. Since then, Mesa et al. (2013) have investigated variation in the diversity and abundance of flower-visiting insects in a Brassica crop.

\* [www.mpi.govt.nz/news-resources/publications](http://www.mpi.govt.nz/news-resources/publications) (accessed 18 March 2014).

† [www.freshfacts.co.nz](http://www.freshfacts.co.nz) (accessed 18 September 2014)

#### BOX 8: MAPPING POLLINATION SERVICES\*

##### Gaps

- Improved understanding of the specific resource requirements (including floral resources, habitat, nesting substrates) of unmanaged native pollinators.\*\*\*\*
- Modelled spatial distribution (and if possible relative abundance) of native pollinators—this is dependent on an improved understanding of specific resource requirements.\*\*\*
- Foraging and pollen dispersal distances for native pollinators.\*\*
- Relative effectiveness of both managed and native unmanaged pollinator species to various food crops.\*\*
- Improved understanding of the spatio-temporal interactions in pollinator efficiency.\*\*

##### Research ideas

- Once the above gaps are addressed, map pollination services provided by native pollinators, including their relative importance compared with non-native and managed pollinators. This may involve testing an existing pollination model (e.g. InVEST) in New Zealand or developing a New Zealand specific approach. (Note that Dymond et al. (2014) have started to develop an approach for modelling pollination services in the Ruamahanga catchment (Wairarapa) based on floral resources, nectar requirements for sustaining bee hives and bee flying distances. Their model, however, does not address native pollinators.)

\* See p. 50 for box explanation

### 6.5.3 Honey production

New Zealand mānuka honey is sought after both locally and internationally. Active mānuka honey is sold at a significant price premium compared with other honeys because of its scientifically proven health benefits, and also acts as a driver for the growth of the total New Zealand honey industry (Coriolis 2012). The current estimated value of the medicinal mānuka honey industry is \$75 million and a 7-year programme of innovation is planned to enable it to grow by a factor of 16 (Coriolis 2012)<sup>116</sup>. The service provided by mānuka (*Leptospermum scoparium*) plants to the New Zealand honey industry is a good example of where an indigenous species provides a superior service, both economically and medicinally, to exotic alternatives (e.g. clover, *Trifolium* spp.), and illustrates one of the contributions of indigenous biodiversity to human wellbeing in New Zealand. It is also an example of an ecosystem service that results from a relationship between an exotic and indigenous species (see Fig. 2). Despite this, it is important to consider that honey bees may have negative effects on indigenous ecosystems and native insects (Newstrom-Lloyd 2013), which may in turn impact other ecosystem services.

Table 14 provides a summary of the data that may be required to produce a basic ecosystem service map of mānuka honey provisioning in New Zealand. While these data are available, some of them are subject to confidentiality constraints.

Table 14. Data requirements and availability for the production of a simple map of mānuka honey as an ecosystem service.

DATA REQUIREMENTS	DATA AVAILABLE
Spatial distribution of beehives	Location data for all registered beehives can be found in the National Apiary Database (National American Foul Brood Management Agency/AsureQuality). The use of this database is subject to constraints to protect potentially sensitive information.  Locations of beehives/apiaries on public conservation land are stored in the Department of Conservation's Permissions Database.
Spatial distribution of mānuka shrublands	Mānuka and kānuka shrubland is a class in the Land Cover Database (LCDB; Steve Thompson & Partners n.d.).
Value of mānuka honey	The value of bulk non-active, active UMF@5+ and active UMF@20+ mānuka honey was \$8–15, \$12–15 and \$40–50/kg, respectively, in 2011/12 (MPI 2012).
Average volume of honey produced per hive	In 2011/12, the average yield of honey per hive was 19.5 and 35 kg/hive for the North and South Islands, respectively (MPI 2012).
Foraging distance of honey bees	Malone (2002) conducted a review of reported foraging distances and found that: <ul style="list-style-type: none"> <li>• Maximum foraging distance was usually 10 km, but up to 13.7 km in one case</li> <li>• Most bees were found within 6 km of their hive</li> <li>• Mean foraging distance was 0.5–1.5 km</li> </ul>

#### BOX 9: MAPPING MĀNUKA HONEY PROVISIONING\*

##### Gaps

- Although sufficient data are available to produce a basic map showing the spatial distribution of this ecosystem service, the confidentiality constraints associated with the National Apiary Database need to be addressed.

##### Research ideas

- Use the data summarised in Table 14 section 6.5.3 to map this service.

\* See p. 50 for box explanation

<sup>116</sup> [www.comvita.co.nz/news-media/general-news/funding-investment-for-manuka-honey-research.html](http://www.comvita.co.nz/news-media/general-news/funding-investment-for-manuka-honey-research.html); [www.massey.ac.nz/massey/about-massey/news/article.cfm?mnarticle=manuka-honey-research-to-grow-industry-10-05-2011](http://www.massey.ac.nz/massey/about-massey/news/article.cfm?mnarticle=manuka-honey-research-to-grow-industry-10-05-2011); and [www.mpi.govt.nz/agriculture/funding-programmes/primary-growth-partnership/high-performance-manuka-plantations](http://www.mpi.govt.nz/agriculture/funding-programmes/primary-growth-partnership/high-performance-manuka-plantations) (accessed 6 May 2014).

#### 6.5.4 Soil natural capital

Historically, many indigenous ecosystems in New Zealand were converted to other land uses, such as agriculture and forestry. This left behind fertile soils, which had originally formed under native vegetation but now form the foundation of present-day production landscapes. Many of these soils have since been both qualitatively and quantitatively degraded (see Dominati et al. 2010). For example, high stock levels can result in increased rates of erosion, and can lead to compaction, decreased drainage and increased surface runoff (Dominati et al. 2010). Similarly, many changes have been made by land managers, such as irrigation, artificial drainage and fertiliser addition (Hewitt et al. 2012). These complexities make it difficult to map and quantify soil natural capital.

Landcare Research and AgResearch are developing a method called the ‘stock adequacy method’ for assessing soil natural capital based on the principles of land evaluation. The goal of this method is to provide techniques for the digital soil mapping community to quantify and map soil natural capital and soil services to enable the soil science community to more effectively engage with decision-makers (Hewitt et al. 2012). This method involves estimating the adequacy of soil natural capital stocks to support the soil processes that enable the provision of soil services required by a specified land use (Hewitt et al. 2012). It acknowledges that to map soil natural capital, one would need to distinguish between soil natural capital and soil built capital (Allan Hewitt, Landcare Research, pers. comm). Therefore, for the purposes of the stock adequacy method, soil natural capital was defined as the natural potential of soils before any improvements (i.e. soils with which the first land managers started and which were formed under unmodified, indigenous ecosystems); and soil built capital as the sum of improvements made to the soil by land managers (Hewitt et al. 2012). Further development of the stock adequacy method then included the consideration of several approaches to distinguish between these two types of soil capital to enable the quantification of soil natural capital (Alan Hewitt, Landcare Research, pers. comm.):

1. Use a historical benchmark in the history of land use and development of an area—due to the complexity associated with the history of land use and environmental change, it was concluded that this would be too difficult, despite New Zealand’s relatively short history of human occupation.
2. Use indigenous remnants or reserves as benchmarks—similarly, it was concluded that this would be difficult because suitable benchmark sites for many soils are not available; and the soils underneath many indigenous remnants and reserves have been altered as a result of human interventions on adjacent land.
3. Use sites supporting low-input agriculture as ‘naturalised benchmarks’—this approach would require one to view relatively stable, long-term additions to soil capital as ‘naturalised’.
4. Accept humans as one of many actors in landscapes that contribute to the overall state and trend of soil natural capital—this approach would accept that soil natural capital refers to the soil as it is presented to humans today (i.e. an amalgam of its pre-human state and built capital).

These challenges demonstrate the complexities that make mapping and quantifying soil natural capital difficult.

#### BOX 10: MAPPING SOIL NATURAL CAPITAL\*

##### Gaps

- Comprehensive understanding of historical land use and environmental change in New Zealand, which is complex despite New Zealand’s short history of human occupation.\*\*\*

\* See p. 50 for box explanation



## 6.6 Freshwater ecosystem services

The hydrological cycle provides many benefits to New Zealanders, including recreational, economic and other cultural benefits. But most importantly, clean drinking water is a basic need, without which life would not exist.

Although New Zealand has relatively abundant freshwater resources, these are not evenly distributed either geographically or seasonally, are facing increasing degradation, and are subject to increasing demand in areas already facing shortages and over-allocation pressures (Harrison Grierson Consultants Ltd & NZIER 2011). The following questions are of particular interest from a conservation perspective:

- How much water is provided by natural and/or protected areas?
- How many people use water provided by largely natural and/or protected catchments?
- Is water cleaner if it originates from largely natural and/or protected catchments rather than catchments that are highly modified by human activities such as agriculture? If so, what is the economic value of the avoidance cost associated with water purification?
- What is the spatial coincidence of water supply, water quality, water use, water demand, and various environmental variables such as land cover, naturalness and protected areas?
- How do freshwater ecosystems and their services affect services associated with the receiving waters such as estuaries and the open coast?
- What values do New Zealanders attribute to freshwater ecosystems and how do these values vary geographically?

Spatial analyses and mapping are useful for answering all of these questions. In the following sections, we explore some of these questions by first discussing water supply, water quality and water use, and then providing an overview of two research projects which explore the social values associated with freshwater ecosystems and demonstrate the potential of incorporating GIS into existing systems or techniques. Research gaps and options for future research directions are provided in Boxes 11–14.

### 6.6.1 Water supply

Crossman et al. (2013) found that water provision and the regulation of water flows were among the most commonly mapped ecosystem services. The spatial and temporal supply of water is influenced by watershed geomorphology, land and water management, and vegetation cover (Mendoza et al. 2011). For example, indigenous tall tussock grasslands yield more water (Ingraham & Mark 2000) than other land cover types, such as forests (Mark & Dickinson 2008). Water from Te Papanui Conservation Park, which is dominated by indigenous tall tussock grasslands, was estimated to be worth \$136 million in total net present value (applying a 7.5% discount rate) for Dunedin City drinking water, hydroelectricity generation and farmland irrigation (Butcher Partners Ltd 2006a).

#### *Existing spatially explicit water balance tools and models*

Spatially explicit water balance models can be used to quantify water availability based on the above-mentioned variables using globally (e.g. Mendoza et al. 2011) or nationally (e.g. Ausseil et al. 2013) available data. Watyfield and TopNet are both spatially explicit water balance models that have been tailored to New Zealand conditions (see Table 15 for a comparison of these).

Watyfield was developed by Landcare Research to examine the effects of land use on water yields and low flows (Fahey et al. 2004). It models daily water transfers of rainfall, interception, evapotranspiration and drainage associated with a soil profile. It was used by Ausseil et al. (2013) to create a national water yield map, which was then used as an indicator for water-flow regulation in Landcare Research's ecosystem services project. Their national water yield map represented mean annual water yield as a function of land cover (forest, scrub, tussock or pasture), soil type and climate. When the model's predicted mean discharge was compared to measured mean discharge from gauged rivers, their model efficiency was 0.95.

Table 15. A comparison of Watyfield (Landcare Research) and TopNet (NIWA)—two water balance models calibrated to New Zealand conditions. (Information taken from Blaschke et al. (2008) and cited references.)

	WATYIELD	TOPNET
<b>Purpose</b>	Predicting the effects of land cover change on water balance in large catchments with limited climate, soil and vegetation data	Continuous simulation of catchment water balance and river flow
<b>Input data</b>	<ul style="list-style-type: none"> <li>• Daily rainfall</li> <li>• Estimates of percent interception for each land cover type</li> <li>• Estimates of soil water parameters (for grouped soil types)</li> <li>• Monthly evapotranspiration</li> <li>• Two base flow parameters</li> </ul>	<ul style="list-style-type: none"> <li>• Digital elevation data</li> <li>• Drainage network branches (linking sub-basins)</li> <li>• Rainfall time series</li> <li>• Soil type (e.g. New Zealand Land Resource Inventory NZLRI)</li> <li>• Sub-basin boundaries</li> <li>• Temperature time series</li> <li>• Vegetation type (e.g. Land Cover Database—LCDB; Steve Thompson &amp; Partners n.d.)</li> </ul>
<b>Outputs</b>	<ul style="list-style-type: none"> <li>• Daily, monthly or annual water yields</li> <li>• Minimum annual 7-day low flows</li> <li>• Soil water storage</li> </ul>	<ul style="list-style-type: none"> <li>• Flow routed through drainage network</li> <li>• Sub-basin plant canopy storage</li> <li>• Sub-basin root zone storage</li> <li>• Sub-basin runoff time series</li> <li>• Sub-basin saturated zone storage</li> </ul>
<b>Examples of use</b>	<ul style="list-style-type: none"> <li>• Model effects of land use change on water balance</li> <li>• Assess the role of fog interception by snow tussock (<i>Chionochloa</i> spp.) grasslands in water yield (Fahey et al. 2011)</li> <li>• Predict national water yield in Landcare Research's Ecosystem Services for Multiple Benefits project (Ausseil et al. 2013)</li> </ul>	<ul style="list-style-type: none"> <li>• Model river flows</li> <li>• Investigate flood routing</li> <li>• Model effects of land use change on water balance</li> <li>• National water accounting for six surface water components—infloWS from rivers, evapotranspiration, outflows to sea, outflows to other regions, net change in soil moisture and net change in snow (Henderson et al. 2011)</li> </ul>

TopNet was developed by NIWA as New Zealand's first national-scale water resource simulation model to assist with national water accounting (Henderson et al. 2011)<sup>117</sup>. It is used to estimate naturalised flow<sup>118</sup>. Although TopNet has not yet been used to create a national water yield map, there is potential for this to be done in the future (Christian Zammit, NIWA, pers. comm.). The model subdivides New Zealand into many thousands of small areas, for each of which it calculates how much water is added as rainfall, how much water leaves as evapotranspiration and river flow, and the change in soil and shallow groundwater storage, based on daily rainfall, daily air temperature, topography, soil and vegetation information (Henderson et al. 2011). Henderson et al. (2011) used TopNet to estimate national surface water accounts for 1995 to 2011. They used the second version of the Land Cover Database (i.e. LCDB2) for vegetation data, and distinguished between indigenous and planted forest. However, they did not distinguish between indigenous and exotic scrub (Christian Zammit, NIWA, pers. comm.), and their estimations were not calibrated with measured data (Henderson et al. 2011). NIWA has recently updated its national model with a newer version of the Land Cover Database (i.e. LCDB3), and they have modified the model's code to allow the full range of land cover classes to be used if this becomes necessary (Christian Zammit, NIWA, pers. comm.).

The contribution of conservation land to national water supply could be estimated by applying the ArcGIS Zonal Statistics tool to a national map of water supply (input raster) and protected areas (input zone feature class). For example, we used Ausseil et al.'s (2013) water yield map and DOC's protected areas layer to estimate that 61% (180 billion cubic metres) of national water yield comes from public conservation land, even though it constitutes only 33% of New Zealand's total land area (see Fig. 13). These figures should be used with caution, however, as Ausseil et al. (2013) assumed that indigenous and exotic forest had the same effect on water yield, and no distinction

<sup>117</sup> <http://tools.envirolink.govt.nz/dsss/topnet> (accessed 15 September 2014).

<sup>118</sup> Defined as 'the rate of water movement past a specified point on a natural stream. The flow comes from a drainage area in which there has been no stream diversion caused by storage, import, export, return flow, or change in consumptive use caused by man-controlled modifications to land use. Natural flow rarely occurs in a developed country' ([www.termwiki.com/EN:natural\\_flow](http://www.termwiki.com/EN:natural_flow); accessed 15 September 2014).

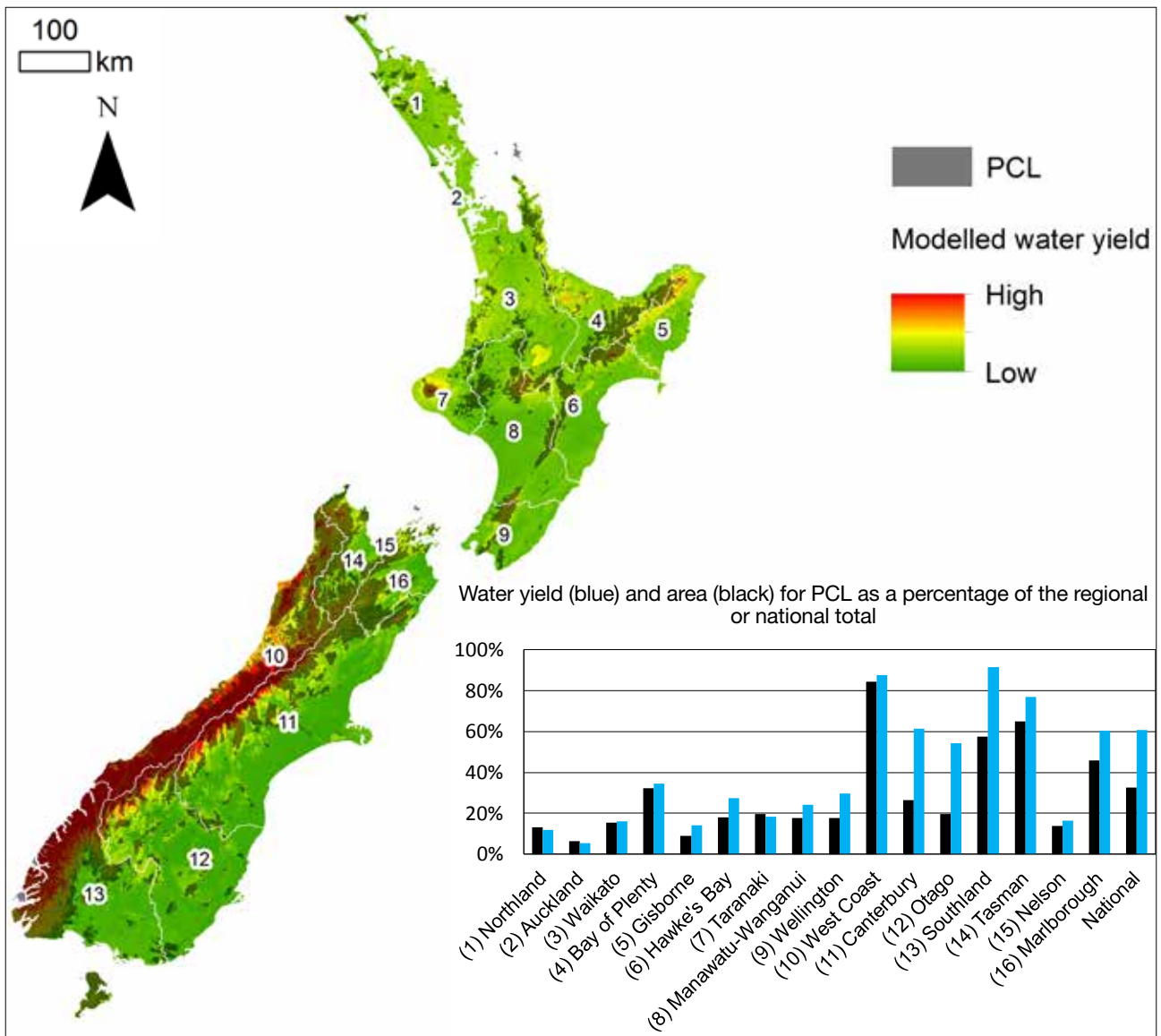

was made between indigenous and exotic scrub. Therefore, the level of distinction between vegetation types would need to be more detailed to produce a more accurate estimate. Research is ongoing to estimate the level of interception from different vegetation types (Anne-Gael Ausseil, Landcare Research, pers. comm.), which could then be upscaled using LCDB classes.

**BOX 11: MAPPING WATER SUPPLY\***

**Gaps**

- Estimates of water interception by different vegetation types.\*\*

**Research ideas**

- Use an existing water yield model (e.g. Watyfield or TopNet) to create a national spatial layer of water yield, using all land cover categories from the latest LCDB version.

\* See p. 50 for box explanation

## 6.6.2 Water quality

Ideally, water quality should be considered alongside any assessment of water supply. This is because the provision of clean water provides additional economic (e.g. avoidance of costs associated with artificial water purification systems) and cultural (e.g. increased water clarity contributing to aesthetic and recreational values associated with a particular landscape) benefits compared with nutrient-rich or polluted water. It is also important from a conservation perspective, as intact indigenous ecosystems generally provide water of higher water quality than human-modified landscapes. This has been illustrated by many studies (e.g. Quinn et al. 1997; Quinn & Stroud 2002; Galbraith & Burns 2007; Ballantine & Davies-Colley 2014), which have shown that water quality measures, such as nutrient and sediment loads, are higher in human-modified catchments than natural catchments.

Water quality has been mapped at a national level for lakes (e.g. Hamill 2006; Sorrell et al. 2006; also see MfE website<sup>119</sup>), groundwater (e.g. see MfE website<sup>120</sup>) and rivers (e.g. Unwin et al. 2010; Unwin 2014; also see MfE website<sup>121</sup>) in New Zealand. MfE reports on water quality state and trends as part of its National Environmental Reporting Programme (Unwin & Larned 2013). As part of this programme, Unwin et al. (2010) built spatially explicit predictive models using random forest models<sup>122</sup> based on 28 environmental variables for 11 river water quality analytes<sup>123</sup> (see Table 16), the latter of which were mapped at a national level. These models were based on data provided by regional and unitary authorities, and the National River Water Quality Network (NRWQN). Model performance, measured by percent variance explained, was satisfactory for most of the 11 analytes. The importance of predictors varied among analytes but, in general, important predictors included catchment elevation, mean catchment slope, measures of catchment geological particle size, calcium and hardness, days per year with rainfall greater than 50 mm, percentage of catchment area with alluvial soils, percentage of catchment area in heavy pasture, and percentage of catchment area under indigenous forest cover. The first two variables showed that water quality tends to decline at low elevations and low gradients (Unwin et al. 2010), which is consistent with intensifying land use throughout lowland New Zealand (Unwin et al. 2010). The two latter variables are also of great interest from a conservation perspective. Percent indigenous forest cover was of moderate to high importance as a predictor of electrical conductivity, oxidised nitrogen, total nitrogen and total phosphorus, all of which declined as indigenous forest cover increased. Percent heavy pasture was the most important predictor for clarity, oxidised nitrogen and total nitrogen, and was also in the top two most important predictors for faecal coliform and *E. coli*. Unsurprisingly, partial residual plots suggested that water quality declined as the percent heavy pasture increased.

In 2011, MfE initiated its National Environmental Monitoring and Reporting Project (NEMaR), which aims to establish more consistent and dependable monitoring procedures for national reporting. Unwin & Larned (2013) contributed to the following components of this project:

- Compiling national datasets on stream macroinvertebrate communities and water quality
- Developing predictive models of water quality state and trends to metrics of catchment-scale geography, climate, geology and land cover
- Trialling the use of composite indices, which are based on selected water quality and invertebrate community metrics, as a tool for characterising national-scale environmental variation

---

<sup>119</sup> [www.mfe.govt.nz/environmental-reporting/fresh-water/lake-water-quality-indicator/water-quality-indicator-lakes.html](http://www.mfe.govt.nz/environmental-reporting/fresh-water/lake-water-quality-indicator/water-quality-indicator-lakes.html) and [www.mfe.govt.nz/environmental-reporting/fresh-water/suitability-for-swimming-indicator/recreational-water-quality-update-oct-2012.html](http://www.mfe.govt.nz/environmental-reporting/fresh-water/suitability-for-swimming-indicator/recreational-water-quality-update-oct-2012.html) (accessed 28 May 2014).

<sup>120</sup> [www.mfe.govt.nz/environmental-reporting/fresh-water/groundwater-quality-indicator/index.html](http://www.mfe.govt.nz/environmental-reporting/fresh-water/groundwater-quality-indicator/index.html) (accessed 28 May 2014).

<sup>121</sup> [www.mfe.govt.nz/environmental-reporting/fresh-water/river-condition-indicator/index.html](http://www.mfe.govt.nz/environmental-reporting/fresh-water/river-condition-indicator/index.html) and [www.mfe.govt.nz/environmental-reporting/fresh-water/suitability-for-swimming-indicator/recreational-water-quality-update-oct-2012.html](http://www.mfe.govt.nz/environmental-reporting/fresh-water/suitability-for-swimming-indicator/recreational-water-quality-update-oct-2012.html) (accessed 28 May 2014).

<sup>122</sup> Random forests are a form of multivariate regression.

<sup>123</sup> Defined as 'a substance whose chemical constituents are being identified and measured' ([www.oxforddictionaries.com/definition/english/analyte](http://www.oxforddictionaries.com/definition/english/analyte); accessed 6 May 2014).

Table 16. The 28 predictor variables that Unwin et al. (2010) used to model and map 11 water quality analytes.

VARIABLE TYPE	VARIABLE NAME
Water quality analytes	Ammoniacal nitrogen (NH <sub>4</sub> N)
	Clarity (black disc visibility)
	Dissolved reactive phosphorus
	Electrical conductivity
	Enterococci
	<i>Escherichia coli</i>
	Faecal coliform
	Oxidised nitrogen (NO <sub>3</sub> N)
	Total nitrogen
	Total phosphorus
	Total suspended solids
Predictor variables <sup>a</sup>	Calcium
	Catchment area
	Catchment elevation
	Evapotranspiration
	Hardness
	Lake index
	Maximum temperature
	Mean flow
	Mean slope
	Minimum temperature
	Particle size
	Percent catchment area covered by bare ground
	Percent catchment area covered by exotic forest (plantations, deciduous forests, shelter belts)
	Percent catchment area covered by indigenous forest (including contiguous subalpine and alpine vegetation)
	Percent catchment area covered by pastoral heavy (cropland, vineyards, orchards, high-producing exotic grassland)
	Percent catchment area covered by pastoral light (low-producing or depleted grassland, tussock)
	Percent catchment area covered by scrub (including fern, mānuka, kānuka, gorse <i>Ulex europaeus</i> / broom <i>Cytisus scoparius</i> , matagouri <i>Discaria toumatou</i> , exotic shrubs)
	Percent catchment area covered by urban (including dumps and mines)
	Percent catchment area covered by wetland
	Percent catchment area with alluvial soils
	Percent catchment area with glacial soils
	Percent catchment area with peat soils
	Phosphorus
	Rain days > 10 mm
	Rain days > 50 mm
	Rain days > 200 mm
	Rain variability
Reach elevation	

<sup>a</sup> Land cover variables were sourced from the New Zealand Land Cover Database 2 (LCDB2). All other variables were sourced from the River Environment Classification (REC).

Unwin & Larned (2013) compiled data from regional council State of Environment and NIWA's National River Water Quality Network programmes into datasets of 789 water quality sites and 519 invertebrate sites, and obtained catchment-level descriptors for each site using the River Environment Classification and Freshwater Environments of New Zealand (FENZ). Random forest models were then used to build national spatially explicit predictive models of state, trends and indices for 50 water quality variables (including physical-chemical water quality and invertebrate community metrics) based on site-specific catchment descriptors (predictive variables). Similarly to Unwin et al. (2010), they found that the best predictors were generally catchment topography (including elevation and mean slope), climate (including rainfall variability, mean temperature) and catchment land cover (particularly the percentage of catchment covered by indigenous forest or heavy pastoral agriculture). The most successful

models were for total nitrogen concentration, *E. coli*, total phosphorus concentration and Semi-Quantitative Macroinvertebrate Community Index for hard-bottom streams, with over 70% of the observed inter-site variation being explained. Unwin & Larned (2013) also produced maps of the current national state and trend for the following 12 physical-chemical water quality variables and four invertebrate community metrics:

**Physical-chemical water quality variables:**

- Black disc clarity
- Total suspended solids
- Turbidity
- Mean annual temperature
- Dissolved oxygen
- Dissolved oxygen % saturation
- *E. coli*
- Ammonium nitrogen (NH<sub>4</sub>N)
- Nitrate nitrogen (NO<sub>3</sub>N)
- Total nitrogen
- Dissolved reactive phosphorus
- Total phosphorus

**Invertebrate community metrics:**

- Invertebrate taxonomic richness
- Semi-quantitative Macroinvertebrate Community Index
- Ephemeroptera, Plecoptera and Trichoptera taxonomic richness
- Percentage of Ephemeroptera, Plecoptera and Trichoptera abundance

The success of Unwin & Larned's (2013) trend modelling was limited by data availability and the fact that a large number of sites had no clear significant trend. Their results illustrated the difficulty in obtaining credible fits and showed that the datasets used were of limited value for the prediction of long-term water quality trends at a national scale (Unwin & Larned 2013). Furthermore, their results for multi-metric and composite water quality indices were also problematical, and showed that considerable further work is necessary before multi-metric and composite water quality indices can be consistently generated and interpreted at a national scale (Unwin & Larned 2013).

Since DOC is interested in the ecosystem services provided by indigenous biodiversity, one could test the effect of the percent catchment area protected as public conservation land (or protected areas) on water quality. One could also test the effects of a greater variety of land cover types, and compare indigenous with exotic or human-modified land cover types. These land cover types could be ranked according to (for example) human population density, industry production measures, level of protection, and/or distance from population centres and agricultural landscapes. Spatial coincidence between water quality and the above-mentioned variables could also be investigated, using overlap, coincidence and correlation analyses (see Vačkář et al. (2012) and Egoh et al. (2009) for examples of these analyses).

***Existing spatially explicit water quality tools and models***

A wide range of water quality tools and models exist, including for nutrients, pesticides, sediment loss, erosion and bacteria; for informing land management practices, including in relation to fertiliser application, irrigation and stocking rates; and for both rural and urban contexts (Anastasiadis et al. 2013). However, 'off the shelf' software is not always suitable for use in all situations and may require customisation (e.g. Ellis & Searle 2013). Anastasiadis et al. (2013) discussed water quality models (including spatially explicit models) that are currently in use for modelling the amount of nitrogen and phosphorus leaching from rural land, and their concentrations and loads in freshwater.

Farm-scale nutrient models are used to estimate nutrient loss in response to land management decisions at the scale of a farm, paddock or plot (Anastasiadis et al. 2013). For example, OVERSEER was used by Ausseil et al. (2013) and Dymond et al. (2013b) to estimate and map at a national scale nitrogen leaching rates based on soil formation, climate data and stocking rates. By comparison, catchment-scale transport models consider the speed and distribution of nutrients in their pathway as they travel across catchments and larger areas to enter lakes and rivers via groundwater and surface water (Anastasiadis et al. 2013). Such models can be used to consider both diffuse (i.e. non-point) and point sources of nutrients (Anastasiadis et al. 2013). Anastasiadis et al. (2013) provided several examples of spatially explicit catchment-scale transport models, but most of these are intended for use at catchment and regional scales. An exception is CLUES, which can be applied at catchment, regional and national scales to evaluate different land use scenarios (Anastasiadis et al. 2013).

CLUES was developed for MPI by NIWA in collaboration with MfE, Lincoln Ventures, Harris Consulting, AgResearch, Plant and Food Research, and Landcare Research. It is a large-scale water and nutrient transport model that produces spatial estimates of nutrient loss, loads and concentrations in freshwater bodies (including wetlands) at a catchment, regional or national level (Anastasiadis et al. 2013); and it can also be used to assess impacts on estuarine ecosystems services when combined with two other existing tools<sup>124</sup>. CLUES can be used for freshwater management as a visualisation tool to facilitate communication between various stakeholders, to assess current and future states of freshwater bodies, to help set load limits for nutrients, sediments and bacteria discharged into catchments, and to evaluate the effects of mitigation measures required to meet these limits (Semadeni-Davies et al. 2014). It has been used in several regions (e.g. Waikato, Manawatu, Canterbury, Southland, Bay of Plenty) and at a national level (Anastasiadis et al. 2013). An example of the latter was the nutrient modelling done by Parshotam et al. (2013) for the Parliamentary Commissioner for the Environment, whereby CLUES was used to model the effects of land use change and intensification on nutrient loads and concentrations in New Zealand streams over recent periods of intensification (since 1996) and into the future (until 2020). National maps of modelled nitrogen and phosphorus current yields<sup>125</sup> (2008), recent yield increases (1996–2008) and future yield increases under different scenarios (2008–2020) were produced for New Zealand streams.

#### BOX 12: MAPPING WATER QUALITY\*

##### Gaps

- Improved land use and land management information.\*\*\*
- Better understanding of the role of soil in leaching nutrients.\*\*

##### Research ideas

- Model water quality in New Zealand based on available water quality data, such as data from NIWA's National Rivers Water Quality Network; and test the effect of variables of interest to conservation (e.g. percentage catchment area protected as public conservation land; land cover; FENZ condition scores) using a similar approach to Unwin et al. (2010).
- Compare the spatial distributions of water quality, protected/natural areas, and human pressure proxies such as human population density and agricultural production.

\* See p. 50 for box explanation

<sup>124</sup> NIWA developed the CLUES estuary tool by combining three existing tools: CLUES, Coastal Explorer and the ACER estuarine hydraulics model. See [www.niwa.co.nz/freshwater-and-estuaries/research-projects/estuarine-water-quality-the-clues-estuary-tool](http://www.niwa.co.nz/freshwater-and-estuaries/research-projects/estuarine-water-quality-the-clues-estuary-tool) (accessed 14 January 2015).

<sup>125</sup> Parshotam et al. (2013) defined generated yield (kilograms per hectare per year) as the mean annual load of nutrient generated in the catchment and entering the stream via surface and subsurface pathways per unit area.

### 6.6.3 Water use

In New Zealand, information (including spatial data) about drinking water sources and treatment plants can be found in Water Information New Zealand (WINZ) and the National Environmental Standards for Sources of Human Drinking Water Database (see section 4.3.3). These databases could be used in combination with other data and/or research to explore the following questions:

1. How many people drink water that at least partly originates from surface waters whose catchments are dominated by natural cover? (See Fig. 6)
2. What is the difference in water quality and the level of treatment required between water originating from largely natural/protected catchments and other types of catchments (e.g. dominated by agriculture)? If a difference is observed, what is the economic value of the avoidance cost associated with water purification services for those types of catchments providing water of higher quality?

Spatial data on consented water take information is also available from regional authorities. As part of MfE's National Environmental Reporting Programme, a report was commissioned on freshwater take consents for consumptive and non-consumptive uses (Aqualinc Research Ltd 2010). This involved collecting existing consent information from regional authorities, and estimating water allocation volumes and actual water abstraction volumes. Such information can be used to explore the spatial patterns of use and allocation.

MfE compared surface water allocation for consumptive use with renewable freshwater resource in New Zealand<sup>126</sup> using data from Aqualinc Research Ltd (2010) and Leathwick et al. (2010b), and modelled mean annual low flow (MALF) data for stream segments from NIWA. These data were used to produce a map of potential surface water allocation pressure in 2010, in which surface water catchments are colour coded according to the proportion of average annual low flow that is allocated (see Fig. 14). This map provides an indication of catchments (e.g. Otago, Canterbury, Marlborough) that are at risk of surface water allocation pressures during dry periods and so indicates which catchments may require further investigation for management options<sup>127</sup>—although it should be noted that this does not include takes from storage or lake sources, as MALF data are not available for these.

Figure 14 illustrates the importance of quantifying ecosystem service supply versus demand to ensure that human use does not put excessive pressures on the natural environment and its resources.

#### BOX 13: MAPPING WATER USE\*

##### Gaps

- Improved data on actual water use. (Note that a relatively new regulation (Government National Regulations and Reporting Water Takes 2010) is now in place that will require consented takes (except for consented takes of less than 5 litres per second, and consents for geothermal water, coastal water or non-consumptive use) to be monitored with a flow meter; MfE 2011.)\*\*

##### Research ideas

- Estimate and map the number of people relying on water sourced from catchments dominated by indigenous vegetation and/or mostly protected catchments. (Note: Several data limitations would need to be addressed, as outlined in section 4.3.3.).
- Compare the spatial distributions of water yield, water quality, water use consents, protected/natural areas, and human pressure proxies such as human population density and agricultural production.

\* See p. 50 for box explanation

<sup>126</sup> [www.mfe.govt.nz/more/environmental-reporting/fresh-water/freshwater-demand-indicator/freshwater-demand-allocation-0](http://www.mfe.govt.nz/more/environmental-reporting/fresh-water/freshwater-demand-indicator/freshwater-demand-allocation-0) (accessed 30 April 2015).

<sup>127</sup> [www.mfe.govt.nz/more/environmental-reporting/fresh-water/freshwater-demand-indicator/freshwater-demand-allocation-0](http://www.mfe.govt.nz/more/environmental-reporting/fresh-water/freshwater-demand-indicator/freshwater-demand-allocation-0) (accessed 30 April 2015).



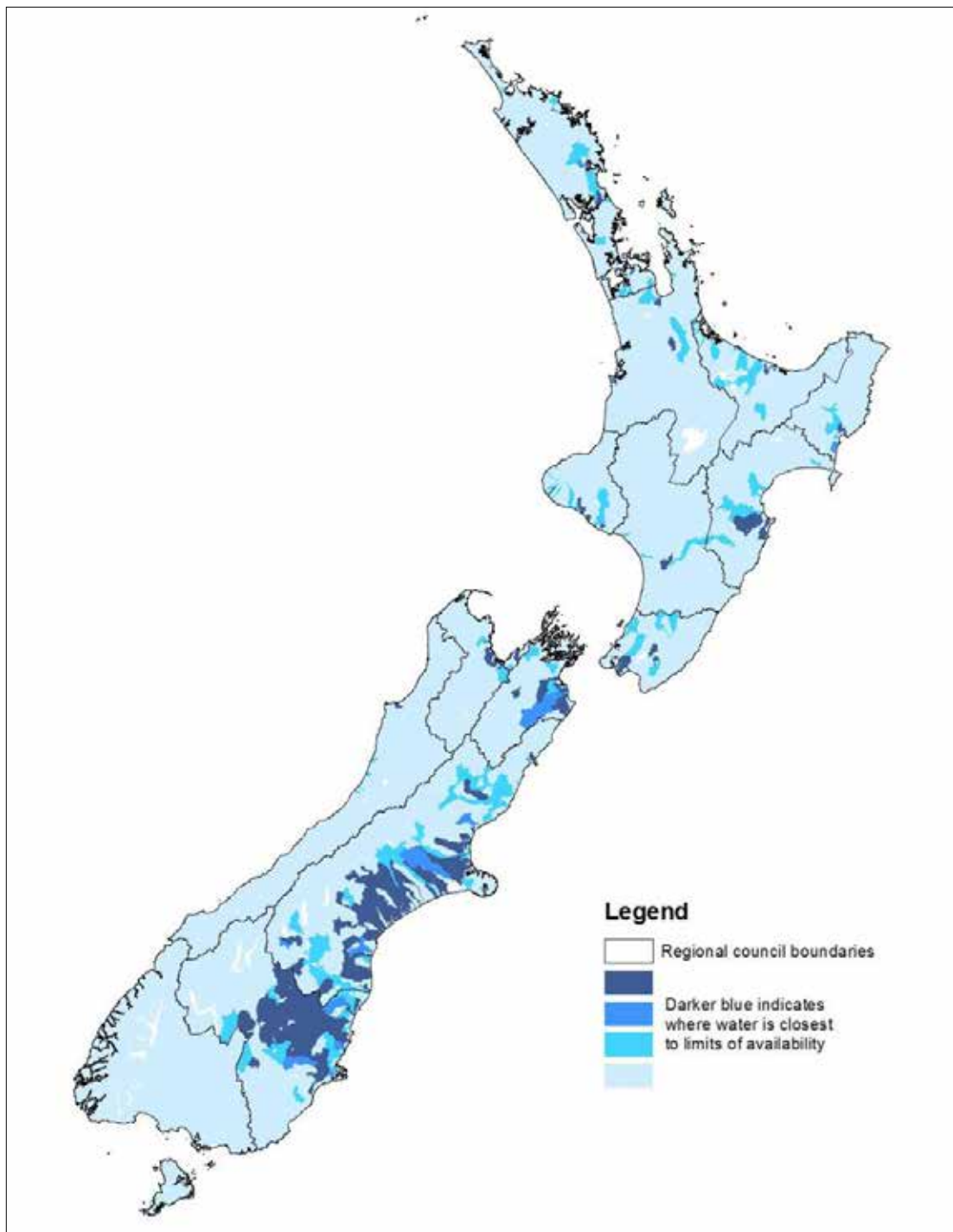

Figure 14. Potential surface water allocation pressure, 2010. Surface water catchments are colour coded according to the proportion of average annual low flow that is allocated, thereby indicating which catchments may be at risk of surface water allocation pressures during dry periods

Acknowledgements: Map created by Ministry for the Environment using data from Leathwick et al. (2010b), Aqualinc Research Ltd (2010) and NIWA.

#### 6.6.4 Social values of freshwater ecosystem services

The assessment and prioritisation of social values associated with freshwater ecosystems and their services are important to guide decision-making, management and policy. Integrating GIS with existing techniques is useful for spatial planning and to ensure that spatial heterogeneities associated with various values are considered. Below, we briefly discuss two different research projects to demonstrate how GIS can be incorporated into existing assessment techniques.

## River Values Assessment System (RiVAS)

A team managed by Professor Ken Hughey (Lincoln University) developed a system called the River Values Assessment System (RiVAS)<sup>128</sup> as a result of a project on prioritising river values that started in 2008<sup>129</sup>. This system uses an expert panel-based multi-criteria analysis approach to prioritise a set of rivers for a particular value. RiVAS+ is an extension of RiVAS that also takes into account future potential value under different management actions. The resulting output comes in the form of a spreadsheet, with key primary attributes rated as low, medium or high national, regional or local significance. Ratings can be allocated based on scientific data or, if unavailable, expert opinion. A ten-step system is used for RiVAS, with an additional four steps for RiVAS+ if future potential river value under different interventions is also assessed. The methods and several strengths and weaknesses of RiVAS are outlined in Table 17.

Table 17. RiVAS methods, strengths and weaknesses.

METHODS*	STRENGTHS†	WEAKNESSES†
RiVAS		
1. Define river value categories and river segments	<ul style="list-style-type: none"> <li>Different values can be assessed on a standardised numeric scale using the same method.</li> </ul>	<ul style="list-style-type: none"> <li>GIS has not yet been fully integrated into the system.</li> </ul>
2. Identify attributes		
3. Select and describe primary attributes	<ul style="list-style-type: none"> <li>An expert-panel based approach engages stakeholders and allows them to define what attributes (and their thresholds) contribute to the significance of river values. This is a particular strength for the assessment of values that are emergent, subjective and changeable.</li> </ul>	<ul style="list-style-type: none"> <li>Difficulties may be experienced in applying RiVAS to certain values—for example, using RiVAS to define tangata whenua values can be problematic as compartmentalising and ranking values may be in conflict with the world view of many Māori groups (Tipa 2010); and identifying nationally significant rivers for some values may only be possible once a national database has been created (Mary-Anne Baker, Tasman District Council, pers. comm.).</li> </ul>
4. Identify indicators		
5. Determine indicator thresholds		
6. Apply indicators and indicator thresholds		
7. Weight the primary attributes		
8. Determine the river significance	<ul style="list-style-type: none"> <li>Best available information is used—where scientific data are unavailable, expert opinion is used.</li> </ul>	<ul style="list-style-type: none"> <li>It may be difficult to find enough suitable experts.</li> </ul>
9. Outline other relevant factors		
10. Method review—review assessment process and identify future information needs	<ul style="list-style-type: none"> <li>Potential effects on river values by management interventions can be tested with RiVAS+.</li> </ul>	<ul style="list-style-type: none"> <li>Some experts may be unwilling to fully engage in the process.</li> </ul>
RiVAS+		
11. Identify rivers and interventions	<ul style="list-style-type: none"> <li>Highlights gaps in data required to manage for particular end uses.</li> </ul>	<ul style="list-style-type: none"> <li>It may be difficult for experts to reach agreement on contentious issues.</li> </ul>
12. Apply indicators and indicator thresholds for potential value	<ul style="list-style-type: none"> <li>Highlights key water body attributes that may require management.</li> </ul>	<ul style="list-style-type: none"> <li>It may be difficult to ensure that value definitions are consistently understood by all participants.</li> </ul>
13. Weight the primary attributes for potential value	<ul style="list-style-type: none"> <li>Enables clustering of key attributes that may need to be addressed in monitoring, data gathering or investigation programmes.</li> </ul>	<ul style="list-style-type: none"> <li>Non-participants may remain sceptical of the reliability and robustness of the process.</li> </ul>
14. Determine river potential value	<ul style="list-style-type: none"> <li>Can be used for a variety of end uses, including informing policy and regional planning, informing monitoring programmes, and demonstrating freshwater values to communities and local stakeholders.</li> <li>Developed and trialled in New Zealand.</li> <li>Can be applied to other ecosystems, not just rivers.</li> </ul>	<ul style="list-style-type: none"> <li>There is no provisioning in the system for updating with new or changing information and expert views on a regular basis. This is particularly important for values that are emergent, subjective and changeable.</li> <li>A new expert panel needs to be formed to assess each type of river value separately.</li> </ul>

\* Reproduced from [www.lincoln.ac.nz/Documents/LEaP/RiVAS%20-%20Northland%20RC%20presentation%20Nov%202012.pdf](http://www.lincoln.ac.nz/Documents/LEaP/RiVAS%20-%20Northland%20RC%20presentation%20Nov%202012.pdf) (accessed 19 August 2013).

† Some of this information was obtained from [www.lincoln.ac.nz/Documents/LEaP/RiVAS%20-%20Northland%20RC%20presentation%20Nov%202012.pdf](http://www.lincoln.ac.nz/Documents/LEaP/RiVAS%20-%20Northland%20RC%20presentation%20Nov%202012.pdf) (accessed 19 August 2013).

<sup>128</sup> Implementation consultant: Dr Kay Booth (formerly Lindis Consulting); key council contact: Mary-Anne Baker (Tasman District Council). See [www.lincoln.ac.nz/research-centres/leap/environmental-management-planning/projects/prioritising-river-values](http://www.lincoln.ac.nz/research-centres/leap/environmental-management-planning/projects/prioritising-river-values) (accessed 16 August 2013).

<sup>129</sup> [www.lincoln.ac.nz/Research-Centres/LEaP/Environmental-Management-Planning/Projects/Prioritising-river-values](http://www.lincoln.ac.nz/Research-Centres/LEaP/Environmental-Management-Planning/Projects/Prioritising-river-values) (accessed 11 September 2014).

To date, RiVAS has been used to carry out case studies on white-water kayaking, river swimming, salmonid angling, native bird life, native fish, natural character, irrigation, tangata whenua values, water for domestic purposes and whitebaiting in a variety of regions (Hughey & Baker 2010a, b; Booth 2012; Booth et al. 2012a–f, 2013a–c; Bull et al. 2012; Clapcott et al. 2012; Harris 2012a, b; Higgs et al. 2012; Hughey & Booth 2012; Hughey et al. 2012, 2013). RiVAS is also being applied to hydropower generation (trial application)<sup>130</sup>. These case studies have been used by regional councils to help stakeholders develop an information base to improve understanding of the values associated with rivers, and to inform decision-making.

Although GIS was used to produce maps in later studies (i.e. from 2012 onwards), it has not yet been fully incorporated into the entire assessment system. Booth et al. (2013b) identified the need to develop a national GIS-based database of RiVAS information, which could be used by government agencies such as MfE, DOC and MPI for planning, including cross-boundary regional planning. However, in order to fully incorporate GIS into RiVAS, some of the following alterations may need to be considered:

1. Attributes chosen to describe river values need to be spatially-applicable
2. An effective system needs to be developed for spatially displaying values and attributes
3. Consistent methods need to be followed for spatially defining river values—for example, values could be allocated to river segments defined within the River Environment Classification

The continued development of RiVAS into a GIS-based system could provide a solution to mapping ecosystem service values that have little available data, or are difficult to measure or quantify. It would also allow the spatial coincidence and distribution of different values and other spatial features to be compared. Because of its high stakeholder involvement, it may be particularly useful for mapping social values, which are subjective, emergent and changeable, as long as regular updates are made. Although RiVAS has been designed to be used for values associated with rivers, it could equally be applied to other ecosystems. For example, we mapped the distribution of public conservation land in relation to rivers with significant values for swimming, natural character and native fish in Northland using data from Booth et al. (2013a, b) and Hughey et al. (2013) as identified using RiVAS (see Fig. 15). These maps and the accompanying table show that 20%, 77% and 100% of values for swimming, natural character and native fish, respectively, intersected with public conservation land. Statistical tests could be used to determine the level of congruence between these values and public conservation land.

### ***Estimating the non-market value of water quality in Canterbury***

It is important to not only explore the impacts of various management scenarios on ecosystem goods and services, but also to explore what values different members of society place on them (Wilson et al. 2004) and, therefore, the possible impacts of management and policy on society. Although it can be controversial, non-market valuation is one way to develop a better understanding of public preferences by identifying the relative values associated with various attributes (e.g. water quality, fishing and scenic values). These values can then be prioritised to inform management decisions and policy. It should be noted though that considering the influence of spatially explicit variables on relative values can help to mitigate bias (Tait et al. 2012), as illustrated by the example below.

As part of a non-market valuation project on water quality in Canterbury<sup>131</sup>, Tait et al. (2012) combined GIS and a choice experiment to develop a method for evaluating the influence of spatially explicit variables on respondents' willingness-to-pay for river and stream conservation

---

<sup>130</sup> [www.lincoln.ac.nz/Documents/LEaP/RiVAS%20-%20Northland%20RC%20presentation%20Nov%202012.pdf](http://www.lincoln.ac.nz/Documents/LEaP/RiVAS%20-%20Northland%20RC%20presentation%20Nov%202012.pdf) (accessed 19 August 2013).

<sup>131</sup> <http://library.lincoln.ac.nz/Lincoln-Home/research-themes/ecosystem-services/Research-Projects-and-Websites/Estimating-the-Non-market-Value-of-Water-Quality-in-Canterbury> (accessed 4 December 2014).

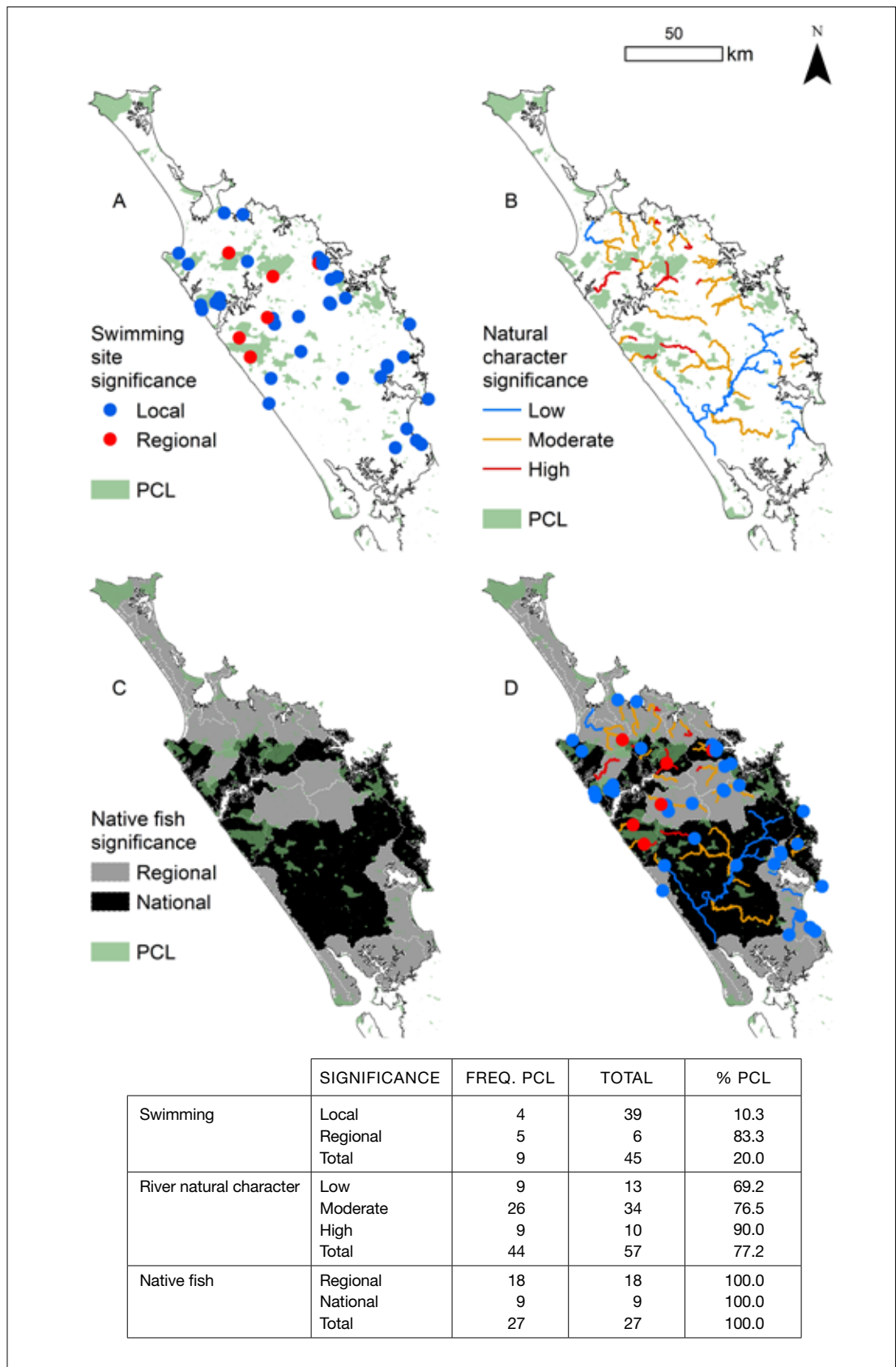

Figure 15. The distribution of public conservation land (PCL) in relation to rivers with the following significant values in Northland as identified using the River Values Assessment System (RiVAS): A. swimming; B. natural character; C. native fish; and D. all the above. The accompanying table (bottom) shows the frequency (Freq. PCL) and percentage (% PCL) of values that intersect PCL.

Acknowledgements: Spatial data for swimming, natural character and native fish significance were provided by Booth et al. (2013b), Booth et al. (2013a) and Hughey et al. (2013), respectively.

programmes. More specifically, they investigated the influence of respondents' local water quality, measured using three spatially explicit water quality variables (i.e. Suitability for Recreation grades—SRC; Semi Quantitative Macroinvertebrate Community Index scores—SQMCI; and waterway flow rates), on their willingness-to-pay for improvements in combinations of three attributes that reflect policy outcomes associated with waterway conservation (i.e. health risk from recreational contact; ecological quality; and number of low flow months). Their results showed that those respondents living near low-quality waterways were willing to pay more for improvements relative to those who live near high-quality waterways (Tait et al. 2012). Further to this, Tait et al. (2012) showed that the magnitude of welfare estimates would be substantially underestimated if data on respondents' local water quality were excluded. These findings support the notion that stakeholders often place greater value on ecosystem services when they experience or witness these being threatened or degraded. In addition, they demonstrate that using GIS to include spatially explicit variables may help to improve estimation methods by yielding a more accurate view of the distribution of benefits resulting from the implementation of policies.

#### BOX 14: MAPPING SOCIAL VALUES OF FRESHWATER ECOSYSTEM SERVICES\*

##### Gaps

- GIS capability enabled in RIVAS.\*
- Comprehensive understanding of social values and preferences in terms of freshwater ecosystems and their services.\*\*\*

##### Research ideas

- Develop a national GIS database of social values of freshwater values—this could be done by incorporating GIS into RIVAS or by developing a similar but GIS-based system.

\* See p. 50 for box explanation

## 6.7 Marine and estuarine ecosystem services

Marine, coastal and estuarine ecosystems deliver a range of ecosystem services. In New Zealand, marine ecosystem services have been explored spatially at a national level by MPI and DOC, as discussed in sections 4.4.2–4.4.4. However, this work has often been limited to areas near the coast. The current lack of work in mapping ecosystem services associated with the wider marine environment may be due to:

- Variability in available data (see sections 4.1.4 & 4.1.5)
- A lack of suitable indicators—for example, while human infrastructure and amenities associated with the coast may provide a convenient indicator for some provisioning and cultural services, such indicators may not be available further out to sea
- Reduced accessibility compared with coastal waters, where greater accessibility makes it easier to collect primary data
- Uncertainties around spatial scale, such as a lack of knowledge on the minimum or optimal area required for service generation
- The sheer size of the area, with the EEZ (12–200 nautical miles<sup>132</sup>) being c. 4 million km<sup>2</sup> in area<sup>133</sup>

There is also a lack of any national-scale mapping projects on ecosystem services specifically provided by estuarine environments. This is of concern considering that, for their size, estuaries provide a disproportionately large number of services compared with other environments (Costanza et al. 1997). For example, estuaries sequester and store carbon (Chmura et al. 2003), provide nursery grounds for commercial and recreational fish species including whitebait (e.g.

<sup>132</sup> [www.lin.govt.nz/sea/nautical-information/maritime-boundaries/maritime-boundary-definitions](http://www.lin.govt.nz/sea/nautical-information/maritime-boundaries/maritime-boundary-definitions) (accessed 1 May 2015).

<sup>133</sup> [www.fish.govt.nz/en-nz/Environmental/default.htm](http://www.fish.govt.nz/en-nz/Environmental/default.htm) (accessed 1 May 2015).

McDowall 1976), provide habitat for rare birds (Owen et al. 2006), reduce the impacts from storms and floods (Dahdouh-Guebas et al. 2005), contribute to nutrient cycling and water filtration (McLay 1976), and are used for recreation, tourism (Costanza et al. 1997) and Māori customary uses (McDowall 2011). However, until estuaries themselves have been properly defined spatially (see sections 4.1.3 & 4.1.5), this gap cannot be addressed.

When mapping ecosystem services in marine and estuarine environments, it is important to consider the following (Simon Thrush, NIWA, pers. comm.):

- Although important in all systems, connectivity is a greater feature in the processes and functioning of marine ecosystems—i.e. marine ecosystem services are often underpinned by diverse and spatially widespread functions (Townsend et al. 2011). This means that humans may place high importance on a particular area for a particular service without realising that the service is actually reliant on the processes occurring in another area with a perceived lower value.
- Ecological and environmental data for marine and estuarine systems are either inadequate or inconsistently available (see sections 4.1.3–4.1.5).

In addition, marine and estuarine ecosystems are impacted by a broad range of stressors that can be terrestrial (e.g. land clearance, land use change and land use intensification can lead to sediment and nutrient loading in rivers, estuaries and coastal waters), marine (e.g. invasive species, pollution, and physical disturbances such as trawling, dredging or harvesting) or global (e.g. ocean acidification and climate change) in origin (e.g. see Baird et al. 2012). These stressors can have significant impacts on the health of estuarine and marine ecosystems, thereby compromising their ability to provide ecosystem services. Alternatively, some of these stressors may enhance the value that humans place on the services provided by these systems—for example, weather-related disturbances and rising sea levels caused by climate change may place a premium on the protection services provided by estuaries and coastal ecosystems (Nelson et al. 2013). Therefore, it is important to consider the processes occurring globally and in connected terrestrial and freshwater ecosystems when mapping marine and estuarine ecosystem services.

Despite the above challenges, methodologies have been developed to map the ecosystem services provided by these environments. Several differing approaches are discussed below, the applications of which could be extended beyond marine and estuarine ecosystems. Summaries of data gaps and future research directions for mapping marine and estuarine ecosystem services and their social values are then provided in Boxes 15 and 16.

### ***Mapping methodologies***

Townsend & Thrush (2010) and Townsend et al. (2011, 2012, 2014b) developed an innovative methodology called the Ecological Principles Approach (EPA), which offers a solution to the challenges mentioned above, and enables planners, managers and stakeholders to consider ecosystem services in ecosystem-based management and marine spatial planning, despite the scarcity of data for marine ecosystems (Townsend et al. 2014b). Importantly, Townsend et al. (2014b: 45) noted:

*While effective management strategies should ideally be built around a comprehensive knowledge of environmental systems, inclusive of the distributions of species and habitats and the complexity of ecological processes, delaying management until the requisite information for complex approaches is collated is not practical... [particularly as] these data are seldom available, especially for environments most in need of management and protection.*

Their methodology involves using general ecological principles, taken from peer-reviewed literature, to link ecosystem goods and services to ecosystem functions. Many of these ecosystem functions are spatially applicable and could therefore be used to map ecosystem services (Townsend & Thrush 2010). For example, food production is related to the ecological principle that benthic productivity decreases as depth increases (Townsend & Thrush 2010).

One can therefore infer food production from bathymetric data, which can be obtained from the New Zealand Marine Ecosystem Classification, NIWA and LINZ. Townsend et al. (2012, 2014b) used this methodology to map ecosystem services in the Hauraki Gulf, including biogenic habitat formation, ecosystem productivity and nutrient recycling. The resulting maps show the intensity of ecosystem service delivery rather than quantifying the ecosystem services. If funding was available, this approach could be applied at a national level to produce an atlas of marine ecosystem services, and cultural services could be included by integrating social methodologies with the EPA approach (Simon Thrush, NIWA, pers. comm.).

An alternative approach is currently being explored by Kathryn Davies (University of Auckland) at Manukau Harbour. This project aims to address the lack of broad stakeholder involvement in many ecosystem service assessment methods (Kathryn Davies, University of Auckland, pers. comm.). Davies' approach involves local stakeholders through participatory modelling workshops, where stakeholders, after becoming familiar with the ecosystem services concept through discussion, carry out an activity where they indicate on a map not only where they perceive ecosystem services to be occurring, but also the relative value associated with each service.

Table 18 provides a comparison of the approaches used by Townsend et al. (2012, 2014b) and Davies (2012). The major advantage of Davies' (2012) approach is that it is likely to inspire local communities to become more involved, and will possibly lead conservation initiatives under the guidance of DOC or other environmental agencies and community groups. Such an approach could help DOC to meet its fourth intermediate outcome objective, which is to encourage more

Table 18. Comparison of ecosystem service mapping methods used in the Hauraki Gulf (Townsend et al. 2012, 2014) and at Manukau Harbour (Davies 2012).

	ECOLOGICAL PRINCIPLES APPROACH— HAURAKI GULF	MANUKAU HARBOUR APPROACH
<b>Methodology</b>	<ol style="list-style-type: none"> <li>1. Identify ecological principles that relate to the ecosystem service in question (e.g. productivity decreases as depth increases)</li> <li>2. Assign appropriate spatial datasets (e.g. depth)</li> <li>3. Rank each dataset into classes based on principle interpretation and literature values, where the ranked values are between 0 and 1 inclusive</li> <li>4. Weight each dataset according to its relative importance to the ecosystem service in question</li> <li>5. Integrate all layers to produce a service map</li> <li>6. Use expert knowledge to assess accuracy and, if necessary, alter the process</li> </ol>	<ol style="list-style-type: none"> <li>1. Hold participatory modelling and co-learning workshops (and interviews if needed):               <ol style="list-style-type: none"> <li>a. Discuss ecosystem services concept</li> <li>b. Identify ecosystem services provided by study area</li> <li>c. Carry out mapping activity to spatially define the occurrence and value of ecosystem services</li> <li>d. Brainstorm possible management scenarios</li> </ol> </li> <li>2. Analyse results using GIS techniques</li> <li>3. Present initial results to community and receive feedback</li> <li>4. Refine results</li> </ol>
<b>Advantages</b>	<ul style="list-style-type: none"> <li>• Based on accepted scientific theory, which may mean that this approach has greater effect on policy and decision-makers</li> <li>• Uses readily available data</li> <li>• Applicable to larger scales</li> </ul>	<ul style="list-style-type: none"> <li>• Involvement of local stakeholders and experts</li> <li>• Local significance and values are captured by actual users of the area who are most affected by management decisions</li> <li>• Public interest and excitement is generated, which, if channelled appropriately, could lead to proactive community-led conservation</li> <li>• The goal is to recognise the values and perceptions of all participants and facilitate co-learning</li> </ul>
<b>Disadvantages</b>	<ul style="list-style-type: none"> <li>• May not capture local significance</li> <li>• May be less likely to influence the actions of local communities because the process does not involve them</li> </ul>	<ul style="list-style-type: none"> <li>• Difficult to do on a large scale</li> <li>• The result may not be an accurate representation of the distribution of ecosystem services, but rather it captures perceptions of ecosystem services, which are subjective and dynamic</li> </ul>

people to engage with conservation and value its benefits (DOC 2014c). By contrast, Townsend et al.'s (2012, 2014b) approach lacks community involvement but may arguably have a greater influence in policy because it is more grounded in ecological principles and is easier to apply at larger scales.

In addition to these methods, a third approach is currently being developed by Townsend et al. (2014a). In 2014, DOC commissioned NIWA to apply a new method, originally applied in the United Kingdom by Potts et al. (2014), to assess the relationship between ecosystem components and ecosystem services for New Zealand's coastal marine environment. Consequently, Townsend et al. (2014a) developed a matrix that relates ecosystem components (rows—e.g. habitat categories as defined in DOC & MFish's (2008, 2011) Coastal Classification and Mapping Scheme, species, biogenic habitats) to ecosystem services (columns—e.g. primary production, nutrient regeneration, food, leisure) in a table. In each matrix cell, ecosystem components are allocated scores representing the significance of their contribution to ecosystem service provision, with these scores being ranked according to the authors' confidence (i.e. whether scores were supported by New Zealand or international literature and/or expert opinion). Although the resulting method has not yet been applied spatially, it was developed with the intention to do so in the future. Before this can be done, however, refinement is necessary—in particular, the minimum and optimal habitat/patch size required for service delivery needs to be considered, as well as the difference between the spatial extent of service generation and that of delivery (Townsend et al. 2014a). In addition, the matrix approach could be improved by incorporating the health of ecosystem components and their susceptibility to stressors (Townsend et al. 2014a). The authors also discussed several challenges and possible options to more effectively include cultural services in the matrix approach.

Mapping ecosystem services has also been a component of the MBIE-funded research project, 'Integrated valuation of marine and coastal ecosystem services'<sup>134</sup>, which aims to develop a robust framework to characterise, quantify, map and value coastal-marine ecosystem services (Clark 2014). It is hoped that this framework will promote coastal-marine management to take a holistic view of ecosystem processes, services and values rather than focussing on single issues, processes and resources (Clark 2014). Nelson Bays was chosen as a case-study site for this research (Clark 2014). As an initial step, Clark (2014) developed an ecosystem map for this area, which will be used in the future to identify areas of ecosystem service provision and then quantify these services. Several challenges had to be addressed during map development and should be considered in future applications of the map—for example (Clark 2014):

- A wide range of data sources were used, each with differing spatial extents
- For areas where no data were available, an educated guess was made if possible to determine the most likely ecosystem present
- It was not possible to map some ecosystem types due to an absence of reliable information
- The map represents a snapshot in time as the spatial extents of some ecosystems fluctuate over time
- Although density and health measures of various species may be available for some areas, these were not included on the map

These issues highlight the difficulties associated with using ecosystem type as an indicator for ecosystem services.

---

<sup>134</sup> [www.mesv.co.nz](http://www.mesv.co.nz) (accessed 3 December 2014).



#### BOX 15: MAPPING MARINE AND ESTUARINE ECOSYSTEM SERVICES\*

##### Gaps

- Spatial definition for estuaries (in progress).\*\*\*
- Many gaps in data and knowledge relating to environmental/ecosystem/habitat characteristics, species distributions and human activities, particularly in the wider marine environment. Some data are available but need to be mapped nationally.\*\*
- Understanding the spatial and temporal variability in ecosystem service provisioning, including the contributions of various ecosystem components.\*\*

##### Research ideas

- Use the Ecological Principles Approach (Townsend & Thrush 2010; Townsend et al. 2011, 2012, 2014b) to map marine ecosystem services at a national level. This may be a substantial project and may require considerable funding. Validation would be required.
- Further develop Townsend et al.'s (2014a) matrix approach to make it spatially explicit.
- Map the real and future potential role of indigenous coastal ecosystems in providing ecosystem services (including their role in buffering and coastal protection) in relation to predicted sea level rise and climate change.
- Conduct research that will increase understanding of the spatial and temporal variability in ecosystem service provisioning, including the contributions of various ecosystem components.

\* See p. 50 for box explanation

#### BOX 16: MAPPING SOCIAL VALUES OF MARINE AND ESTUARINE ECOSYSTEM SERVICES\*

##### Gaps

- Comprehensive understanding of social values in terms of marine and estuarine ecosystems and their services.\*\*\*

##### Research ideas

- Use a participatory mapping method similar to Davies (2012) to map estuarine ecosystem services at several key estuarine systems to increase community interest and engagement in conservation.
- Use a web-based tool such as SeaSketch to conduct a pilot survey at a specified location (e.g. Hauraki Gulf) to determine where people perceive certain ecosystem services, benefits and values to occur. Develop an approach similar to that of Brown & Brabyn (2012b) to model the spatial distribution of perceived ecosystem services, values and benefits associated with marine and estuarine ecosystems.

\* See p. 50 for box explanation

## 7. Conclusions

Problems involving natural heritage, historic heritage and their services are inherently spatial in nature. Therefore, it is essential that the analysis methods and tools used to investigate the distribution of service supply, demand, pressures, and the impact of various management interventions, decisions and policies on these are also spatially explicit. Such analyses (e.g. spatially explicit scenario testing) are critical in decision-making, policy and management, particularly where a decision to enhance one resource, service or value may be at the expense of others. Therefore, in this report, we investigated the data availability and methods that could be used to map at a national level the services and benefits provided by the natural and historic heritage managed by DOC in New Zealand.

It is intended that this report's findings will contribute towards the development of spatial layers and models representing the spatial distribution of ecosystem services and historic heritage services. This, in turn, will help to demonstrate the benefits that New Zealanders receive from natural and historic heritage, and the importance of their conservation. Moreover, it will enable a more comprehensive range of services and values to be taken into account in decision-making, policy, and land use management and planning. This may not only lead to greater gains in the conservation of indigenous biodiversity, indigenous ecosystems and historic heritage in New Zealand, but may also have positive consequences for the wellbeing of New Zealanders (see Roberts et al. 2015).

In this report, we reviewed a range of data of relevance to ecosystem services and historic services, with a focus on the natural and historic heritage managed by DOC. Ecological and biodiversity data, particularly spatially explicit ecosystem classifications, are important for mapping ecosystem services, as different types of ecosystems provide different types of ecosystem services. Similarly, spatial data for historic heritage are important for mapping historic heritage services; and the distribution of human activities and built infrastructure indicates where people are interacting with natural and historic heritage and so deriving benefits from these. In general, spatial data were most readily available for terrestrial ecosystems, and least available for marine and estuarine ecosystems. Improving the resolution of spatial data for indigenous ecosystems in general would, however, be beneficial. The following ecosystem services and values have already been addressed by several New Zealand studies and initiatives, which included mapping or developing spatial indicators at a national level: water regulation, supply and quality; erosion control; climate regulation; marine and coastal economic, tourism and identity values; marine, coastal and freshwater environmental and biodiversity values; terrestrial, freshwater, coastal and marine recreation values and/or opportunities; and landscape values.

A more detailed exploration of the specific data requirements, potential mapping methods, data gaps and potential research directions for several case studies illustrated that:

- It is often possible to devise creative solutions to map services even when data availability is limited and data quality is poor or variable.
- Many different approaches can often be used to map a particular service. Choosing the best option will be dictated by a number of factors, including end purpose, data availability and quality, limitations associated with the data, spatial scale, and available resources.
- When mapping services, it is important to clearly state any limitations and assumptions to prevent misinterpretation of the results.
- Understanding and mapping ecosystem services is a complex and multi-disciplinary area of work.
- Some services could be mapped with little further research, whereas others would require extensive further work. An example of the latter is soil natural capital, which will require many complexities to be resolved. By comparison, there are sufficient data available to map mānuka honey provisioning—although some of the required data are subject to confidentiality constraints.

Despite the large number of gaps and limitations identified overall, there is considerable scope for using existing data and current understanding to map services. This has been illustrated by a number of initiatives, both in New Zealand and elsewhere, which have developed creative solutions to map services in the face of a variety of challenges, including those relating to data availability and discoverability, quality, confidentiality, and ownership. For example, even though data availability is a significant challenge in the marine environment, several marine ecosystem service spatial datasets have been developed (e.g. Beaumont et al. 2008, 2009; MacDiarmid et al. 2008; Allen et al. 2009; Batstone et al. 2009; Samarasinghe et al. 2009; Visitor Solutions Ltd et al. 2012) using creative and credible approaches, such as Townsend & Thrush's (2010) Ecological Principles Approach. Similarly, although cultural services have generally been addressed the least in ecosystem services research compared with other categories (i.e. provisioning, regulating and supporting services), this is an expanding field, with credible methods being developed both internationally and in New Zealand. In the future, it may be beneficial to integrate ecosystem services research with research relating to historic heritage services, as this will allow researchers from both fields to learn from each other and so gain efficiencies, particularly with regard to understanding cultural values associated with natural and historic heritage. Moreover, it will support a systems approach to decision-making. This is particularly relevant to organisations such as DOC that are responsible for conserving both natural and historic heritage.

In the short- to medium-term, such spatial data (both existing and new) could be used to create case studies for educational purposes, stakeholder engagement, and to inform policy, management and decision-making in New Zealand. Once a considerable number of spatial layers have been developed, the following could also be explored with the aid of spatially explicit assessment tools and models:

- The spatial coincidence of various services, benefits and values associated with indigenous biodiversity, historic heritage managed by DOC, public conservation lands and waters, and the pressures that threaten them.
- Whether the spatial distribution of current conservation management priorities coincides with areas of highest value in terms of the benefits provided to New Zealanders.
- The effects of current conservation management practices on the supply of ecosystem services and historic heritage services.

In addition, spatially explicit tools and models are useful for:

- Visualising and clearly articulating the possible impacts of resource use decisions and policies on a comprehensive range of values and stakeholders
- Prioritising areas for protection and/or restoration
- Informing the development of spatially targeted management practices that minimise negative impacts but maximise benefits across a range of values and services
- Developing management strategies and practices that optimise service provision in:
  - Areas where there are conflicting social, environmental and economic values, particularly in places where conservation may otherwise not take place unless mutual benefits can be identified
  - Conservation partnerships, where it is important that benefits to both conservation and partners (e.g. businesses, community groups, iwi) are achieved

Although several spatially explicit ecosystem service tools and models are available, many of these would require further customisation and development before they could be applied in New Zealand. Meanwhile, new tools are being developed, and many of the existing tools and models are continually being improved as knowledge, data and understanding expands.

If such spatial layers and models are developed to support national-level decision-making, it is critical that a consistent framework and approach is used for mapping both ecosystem services and historic heritage services in all four biomes (i.e. terrestrial, freshwater, estuarine and marine

ecosystems) to ensure that decision-making follows a systems approach, which is based on a holistic understanding of these services and the potential impacts of decisions on them. Furthermore, although this report focussed on services of relevance to the natural and historic heritage managed by DOC, holistic and transparent decision-making should also consider the services and benefits provided by exotic biodiversity, human-modified ecosystems and other historic heritage. The discoverability, accessibility and usability of such spatial layers and models, improved data standards (including for metadata), and the availability of guidelines for proper use are also crucial if decision-makers, including in the public and private sectors, are to use these effectively.

This exploratory report has shown that there is considerable scope to map the services and benefits provided by the natural and historic heritage managed by DOC, despite challenges relating to current understanding and data availability for some ecosystem services. In addition, the development and use of spatially explicit ecosystem service models and tools offer great potential to be used to further conservation in public conservation areas and elsewhere.

## 8. Recommendations

The following recommendations outline a possible path of action that could be followed to map the services and benefits provided by indigenous biodiversity, indigenous ecosystems and historic heritage in New Zealand. The intention of such work is to improve understanding of the linkages between New Zealanders' wellbeing and conservation, as well as supporting future decision-making, policy and management in the hope that better outcomes can be achieved for both natural and historic heritage, and society in general.

It should be noted that these recommendations are intended to serve as a starting point for further discussions on mapping ecosystem services and historic heritage services in New Zealand. Ideally, such work will be carried out through collaboration between a wide range of stakeholders, including DOC, other government departments (including local, regional and central government), research institutions and consultancies, community groups, and tangata whenua.

Recommendations are grouped into high-level recommendations, those that can be achieved (or initiated) using existing information and those that require the development of new spatial data. Recommendations are not necessarily listed in chronological order.

### *High-level recommendations*

1. **Form a collaboration that includes a wide variety of agencies and initiatives to develop an overarching goal for this work area in New Zealand, and to develop a strategy and/or business case to achieve it**<sup>135</sup>—Such a goal could be to 'Use a standardised and integrated approach to conduct a comprehensive and integrated GIS-based assessment of ecosystem services and historic heritage services at a national level in New Zealand'. Note that improving the resolution of spatial data for indigenous ecosystems and improving data standards (e.g. relating to projections, metadata) will be of benefit to such an assessment.
2. **Develop a framework that incorporates understanding of historic heritage services, ecosystem services and Māori values**—This will include extensive collaboration with iwi (note: Harmsworth & Awatere's (2013) framework for understanding Māori values in an ecosystem services context may be useful for guiding future work in this area); the development of a typology for classifying the services and benefits provided by historic heritage; and collaboration with experts from a wide variety of fields including the natural sciences, social sciences, and arts and humanities.
3. **Develop a set of guidelines for mapping ecosystem services and historic heritage services in New Zealand at multiple spatial scales**—This may involve forming a collaboration that includes a wide variety of agencies, initiatives and experts from a variety of fields to develop a standardised and integrated mapping approach that would enable comparison across temporal and spatial scales (including between biomes/environments) and between types of services. To enable the inclusion of historic heritage services, cultural ecosystem services and Māori values, the following may be required:
  - a. Historic heritage services:
    - i A systematic methodology for understanding historic and cultural heritage values for individual places, groups of places and landscapes
    - ii Physical, historical, cultural, visitor and service typologies that can be assigned to historic sites

---

<sup>135</sup> Note that the Natural Resource Sector has initiated a 1-year project to explore capturing the value of natural capital in public sector decision-making. It involves (i) conducting a stocktake of what other countries are doing in terms of natural capital assessments and how this may be relevant for New Zealand; (ii) developing case studies to explore considering ecosystem services in public sector decision-making; and (iii) providing advice on future work in this area (Kuntzsch, V. 2014: Update: NRS Senior Executives' meeting, December 2014. Email dated 19 December 2014 from the Chair of the BusinessNZ Natural Resources Group).

- iii A standardised method for creating spatial definitions for historic sites and their values/services
  - b. Cultural ecosystem services—Collaboration with experts from a wide variety of fields will be essential, including the natural sciences, social sciences, the arts and humanities, and economics.
  - c. Māori values—Extensive consultation and collaboration with iwi, including to develop culturally acceptable mapping methods (this process is likely to be informed by research such as that of Harmsworth (1998), who designed a culturally acceptable GIS database of Māori values).
- 4. Assess existing requirements for national reporting on the supply, demand, state and trend of ecosystem services, and then, where possible, develop robust and internationally acceptable spatially explicit indicators**—This could help the New Zealand Government to meet its obligations under international policies such as the Convention on Biological Diversity’s Aichi Targets<sup>136</sup>.

*Recommendations relating to existing information*

- 5. Update and maintain Data Supplements 1 & 2, and make this information freely available both within DOC and externally**—These datasets should be updated and maintained as new spatial data layers of relevance to ecosystem services and historic heritage services are developed, and this information should be made freely available. It is hoped that this will make it easier for researchers and analysts to engage in research related to ecosystem services and historic heritage services. This will also be in alignment with the movement to improve data sharing at a national level within New Zealand, which is promoted by the Government Information and Data Work Programme.
- 6. Create databases that are organised according to an agreed framework of existing GIS layers for the following:**
- a. Ecosystem services—This would relate to the services and benefits provided by indigenous biodiversity and ecosystems. Ideally, this database would eventually be made available to government departments, regional councils, educational institutions and research institutions.
  - b. Historic heritage services—Although this report has only discussed the services and benefits provided by the historic heritage managed by DOC, in the long term such a database could include the services provided by historic heritage managed by other stakeholders. This would require collaboration with these stakeholders, which include Heritage New Zealand, the Māori Heritage Council<sup>137</sup>, NZAA, and the Ministry for Culture and Heritage.
  - c. Māori values relating to ecosystem services and historic heritage services—This database should be culturally acceptable. Its development is likely to be informed by research such as that of Harmsworth (1998), who designed a culturally acceptable GIS database of Māori values. Comprehensive consultation and collaboration with iwi will be a core component of this work.
- These databases will eventually also contain the relevant GIS data and layers developed and/or collected under Recommendations 1, 4, 9, 10, 11, 12 & 13.
- 7. Develop case studies to illustrate the importance of conservation to the wellbeing of New Zealanders**—Individual services or groups of services could be mapped and analysed (including scenario-analyses) to create case studies for educational purposes, external engagement, and to inform policy, management and decision-making.

<sup>136</sup> [www.cbd.int/doc/strategic-plan/2011-2020/Aichi-Targets-EN.pdf](http://www.cbd.int/doc/strategic-plan/2011-2020/Aichi-Targets-EN.pdf) (accessed 16 January 2014).

<sup>137</sup> [www.heritage.org.nz/about-us/maori-heritage-council](http://www.heritage.org.nz/about-us/maori-heritage-council) (accessed 28 May 2014).

8. **Investigate how existing information systems and databases could be further developed to robustly record information of relevance to ecosystem services and historic heritage services (with a focus on spatially explicit data)**—Examples of these include DOC’s Asset Management Information System (AMIS) (section 4.3.1) and Permissions Database (section 4.3.2).
9. **Where possible, build GIS components into existing databases, information systems and programmes of work (including those relating to monitoring, reporting and research)**—This will maximise the usefulness of these databases and information systems, and add value to the outcomes of these programmes. It will also contribute to developing the new spatial layers prioritised under Recommendation 11.
10. **Identify and, where possible, collate regional-level data of relevance to ecosystem services and historic heritage services into national-level datasets**—This will allow the identification of data-sparse and data-rich areas across New Zealand in terms of both service spatial layers and spatial data that could be used to develop such layers. The water allocation and actual water use reports by Aqualinc Research Ltd (2006, 2010) and Lincoln Environmental (2000) are examples of the collation of regional-level data (e.g. regional council water use consents) into a national dataset. Another example is the information review on estuaries that is currently being conducted by DOC, which includes a stocktake of estuarine broad-scale habitat maps that could be used as a starting point to develop a national database in the future. The collation of regional-level data into national datasets will also place New Zealand in a better position to contribute to global databases. An example of this is the United Nations Environment Programme World Conservation Monitoring Centre’s (UNEP-WCMC’s) Global Saltmarsh Atlas, for which contributions are currently required<sup>138, 139</sup>.

### *Developing new spatial layers*

11. **Prioritise the development of new national GIS layers representing ecosystem services and historic heritage services using existing information**—This report provides a starting point for discussion of potential mapping approaches for a range of services, with information needs and possible research ideas summarised in boxes at the end of each case study section. However, since we did not explore all services and benefits, possible mapping methods and data requirements should be explored for services not specifically discussed in this report. The development of new spatial layers should ideally be prioritised according to criteria such as:
  - a. Conservation: How can we most effectively demonstrate the value of ecosystem services and the role of conservation in maintaining or enhancing these to a variety of audiences?
  - b. Resources: It will take longer to develop spatial layers for some services than for others for reasons such as complexity, data intensity, collaboration, technical expertise and various data constraints (e.g. confidentiality, data quality, data gaps). Therefore, it will be important to consider the following questions: Which services have the least data or knowledge gaps? Which services require data that are the most readily accessible? Which services can be mapped without needing to invest in additional resources such as specialised software? Which services can be mapped using existing expertise?
  - c. Collaboration: The development of spatial layers for many services will require collaboration within and between organisations and other stakeholders. Therefore, a

---

<sup>138</sup> Hutton, J. n.d.: An invitation to contribute to the Global Saltmarsh Atlas and to moderate its content through the online Data Validation Tool. Letter from the Director of UNEP-WCMC to potential contributors.

<sup>139</sup> [http://thebluecarboninitiative.org/wp-content/uploads/UNEP-WCMC-Global-Saltmarsh-Layer\\_pdf\\_version.pdf](http://thebluecarboninitiative.org/wp-content/uploads/UNEP-WCMC-Global-Saltmarsh-Layer_pdf_version.pdf) (accessed 4 April 2014).

certain level of flexibility will be needed to start developing spatial layers as potential contributors become available.

- d. Value and outcome: It will be important to consider which services are of most relevance to and are likely to have the greatest impact on decision-making, policy, land use management and planning, and conservation management for the benefit of both conservation and New Zealanders.

**12. Advocate for new priority research that will help to address data gaps and information needs for GIS-based analyses and research on ecosystem services and historic heritage services, including relating to their states, trends, pressures, and the impact of policies and management decisions on these**—As a starting point, this report identifies research ideas and gaps in the boxes at the end of each case study section. For example, primary research ideas relating to historic heritage services may be (i) to collect information on visitation rates to historic sites, and visitor perceptions and attitudes to historic sites and their values; and (ii) to research how people engage with historic sites (e.g. visitation, media) and the benefits they gain from different modes of engagement.

**13. Develop tools for assessing ecosystem services and historic heritage services**—Investigate the needs of various users (e.g. DOC) with respect to such tools. This would include an exploration of spatial or aspatial tools, depending on the intended purpose and the needs of the intended users. In response to the findings, new tools may need to be developed or alternatively existing tools could be tailored to suit the needs identified. The results may also highlight the need for specific spatial data, which could be prioritised for development and/or collection.

## 9. Acknowledgements

We would like to thank all those DOC staff who supported and reviewed this work, including from the Aquatic and Reporting Unit; Conservation Partnerships; Conservation Services Planning Unit; Information Systems and Services Unit; Kahui Kaupapa Atawhai; Natural Capital Technical Network; Partnerships, Historic and Visitor Unit; Planning, Permissions and Land Unit; and the Terrestrial Ecosystems Unit.

The authors would also like to thank people from other organisations who provided data, information or advice, and reviewed this work including from Accounting for Affordable Futures; AgResearch; American Foulbrood Management Agency; AsureQuality; Bodeker Scientific; Centre for Ecology and Hydrology (U.K.); Enviroconnect; Environment Canterbury; Forest & Bird; Gund Institute for Ecological Economics; Institute of Environmental Science and Research; King's College London; Landcare Research; Land Information New Zealand; Lincoln University; Lindis Consulting; Liquid Systems Limited; Ministry for the Environment; Ministry of Health; Ministry for Primary Industries; National Institute of Water and Atmospheric Research; New Zealand Fish and Game; New Zealand Transport Association; Ngā Hau E Whā O Paparāangi; Oregon State University; Ornithological Society of New Zealand; Plant and Food Research; Scion Research; Stanford University; Statistics New Zealand; Tasman District Council; Te Puni Kōkiri (Ministry of Māori Development); Terralink International; U.S. Geological Survey; University of Auckland; University of Canterbury; and Victoria University of Wellington.

Finally, the authors would like to thank the editors, Lynette Clelland (DOC) and Amanda Todd (Contract Editor).



## 10. References

**Note: DOCDM and OldDM numbers refer to DOC's internal electronic file repository system. For copies or information about these reports, please contact the relevant DOC office.**

- Abraham, E.R.; Thompson, F.N. 2011: Estimated capture of seabirds in New Zealand trawl and longline fisheries, 2002–03 to 2008–09. *New Zealand Aquatic Environment and Biodiversity Report No. 79*. Ministry for Primary Industries, Wellington, New Zealand. 68 p.
- Abraham, E.R.; Thompson, F.N. 2012: Captures of birds in trawl fisheries, in the New Zealand Exclusive Economic Zone, during the 2010–11 fishing-year. <https://data.dragonfly.co.nz/psc/v20121101/explore> (accessed 7 April 2015).
- Adamowicz, W.L.; Naidoo, R.; Nelson, E.; Polasky, S.; Zhang, J. 2011: Nature-based tourism and recreation. Pp. 188–205 in Kareiva, P.; Tallis, H.; Ricketts, T.H.; Daily, G.C.; Polasky, S. (Eds): *Natural capital: theory and practice of mapping ecosystem services*. Oxford University Press, New York, USA.
- Aitken, A.G.; Hewitt, E.W. 2009: Fresh facts New Zealand horticulture 2009. Prepared by Martech Consulting Group Ltd for Plant and Food Research, Auckland, New Zealand. 33 p. [www.plantandfood.co.nz/file/freshfacts-brochure-2009.pdf](http://www.plantandfood.co.nz/file/freshfacts-brochure-2009.pdf) (accessed 3 May 2013).
- Allen, W.; Elmetri, I.; Clarke, S.; Gibbons, J.; Clark, K.; Sinner, J.; Jiang, W.; Taylor, M. 2009: Mapping the values of New Zealand's coastal waters. 3. Social values. *Biosecurity New Zealand Technical Paper No. 2010/05*. Ministry of Agriculture and Forestry, Wellington, New Zealand. 39 p. [www.biosecurity.govt.nz/files/pests/salt-freshwater/social-value-mapping.pdf](http://www.biosecurity.govt.nz/files/pests/salt-freshwater/social-value-mapping.pdf) (accessed 28 July 2014).
- Anastasiadis, S.; Kerr, S.; Arbuckle, C.; Elliot, S.; Hadfield, J.; Keenan, B.; McDowell, R.; Webb, T.; Williams, R. 2013: Understanding the practice of water quality modelling. Prepared for the Parliamentary Commissioner for the Environment by Motu Economic and Public Policy Research, Wellington, New Zealand. 28 p. [www.pce.parliament.nz/assets/Uploads/The-Practice-of-Water-Quality-Modelling.pdf](http://www.pce.parliament.nz/assets/Uploads/The-Practice-of-Water-Quality-Modelling.pdf) (accessed 29 May 2014).
- Aqualinc Research Ltd 2006: Snapshot of water allocation in New Zealand. Ministry for the Environment, Wellington, New Zealand. 64 p. [www.mfe.govt.nz/publications/ser/snapshot-water-allocation-nov06/snapshot-water-allocation-nov06.pdf](http://www.mfe.govt.nz/publications/ser/snapshot-water-allocation-nov06/snapshot-water-allocation-nov06.pdf) (accessed 28 July 2014).
- Aqualinc Research Ltd 2010: Update of water allocation data and estimate of actual water use of consented takes 2009–2010. *Aqualinc Report H10002/3* prepared for the Ministry for the Environment, New Zealand. 118 p. <http://www.mfe.govt.nz/publications/water/water-allocation-2009-10/update-of-water-allocation-data-and-estimate-of-actual-water-use-of-consented-takes.pdf> (accessed 8 December 2014).
- Ausseil, A-G.E.; Chadderton, W.L.; Gerbeaux, P.; Stephens, R.T.T.; Leathwick, J.R. 2011a: Applying systematic conservation planning principles to palustrine and inland saline wetlands of New Zealand. *Freshwater Biology* 56: 142–161.
- Ausseil, A-G.; Dymond, J. 2010: Ecosystem services of afforestation on erosion-prone land: a case study in the Manawatu Catchment, New Zealand. International Congress on Environmental Modelling and Software, 5–8 July 2010, Ottawa, Ontario, Canada.
- Ausseil, A-G.E.; Dymond, J.R.; Kirschbaum, M.U.F.; Andrew, R.M.; Parfitt, R.L. 2013: Assessment of multiple ecosystem services in New Zealand at the catchment scale. *Environmental Modelling & Software* 43: 37–48.
- Ausseil, A-G.E.; Dymond, J.R.; Weeks, E.S. 2011b: Provision of natural habitat for biodiversity: quantifying recent trends in New Zealand. Pp. 201–220 in Grillo, O. (Ed.): *Biodiversity loss in a changing planet*. InTech, Rijeka, Croatia. [www.intechopen.com/books/biodiversity-loss-in-a-changing-planet/provision-of-natural-habitat-for-biodiversity-quantifying-recent-trends-in-new-zealand](http://www.intechopen.com/books/biodiversity-loss-in-a-changing-planet/provision-of-natural-habitat-for-biodiversity-quantifying-recent-trends-in-new-zealand) (accessed 28 July 2014).
- Ausseil, A-G.; Gerbeaux, P.; Chadderton, W.L.; Stephens, T.; Brown, D.; Leathwick, J. 2008: Wetland ecosystems of national importance for biodiversity: criteria, methods and candidate list of nationally important inland wetlands. *Landcare Research Contract Report LCO708/158* prepared for the Department of Conservation, New Zealand. 162 p. (DOCDM-320573)
- Bagstad, K.J.; Semmens, D.J.; Waage, S.; Winthrop, R. 2013: A comparative assessment of decision-support tools for ecosystem services quantification and valuation. *Ecosystem Services* 5: 27–39.
- Baird, S.J.; Tracey, D.; Mormede, S.; Clark, M. 2013: The distribution of protected corals in New Zealand waters. *NIWA Client Report No. WLG2012-43* prepared for the Department of Conservation, New Zealand. 96 p. [www.doc.govt.nz/Documents/conservation/marine-and-coastal/marine-conservation-services/pop-2011-06-coral-distribution.pdf](http://www.doc.govt.nz/Documents/conservation/marine-and-coastal/marine-conservation-services/pop-2011-06-coral-distribution.pdf) (accessed 28 July 2014).

- Baird, S.J.; Wood, B.; MacDiarmid, A.; Thompson, D. 2012: Review of threats to New Zealand's marine environment. *NIWA Client Report No. WLG2012-16* prepared for the Department of Conservation by the National Institute of Water and Atmospheric Research (NIWA), Wellington, New Zealand. 19 p. [www.kaiparaharbour.net.nz/Content/Publications/Bairdeta2012\\_Threats\\_to\\_NZ\\_Marine\\_Envnt.pdf](http://www.kaiparaharbour.net.nz/Content/Publications/Bairdeta2012_Threats_to_NZ_Marine_Envnt.pdf) (accessed 19 January 2015).
- Ballantine, D.J.; Davies-Colley, R.J. 2014: Water quality trends in New Zealand rivers 1989–2009. *Environmental Monitoring and Assessment* 186: 1939–1950.
- Batstone, C.; Elmetri, I.; Taylor, M.; Sinner, J. 2009: Mapping the values of New Zealand's coastal waters. 2. Economic values. *MAF Biosecurity Technical Paper No: 2009/05*. Ministry of Agriculture and Forestry, Wellington, New Zealand. 74 p. [www.biosecurity.govt.nz/files/pests/salt-freshwater/economic-value-mapping.pdf](http://www.biosecurity.govt.nz/files/pests/salt-freshwater/economic-value-mapping.pdf) (accessed 28 July 2014).
- Beaumont, J.; D'Archino, R.D.; MacDiarmid, A. 2009: Mapping the values of New Zealand's coastal waters. 4. A meta-analysis of environmental values. *Biosecurity New Zealand Technical Paper No: 2010/08*. Ministry of Agriculture and Forestry, Wellington, New Zealand. 70 p. [www.biosecurity.govt.nz/files/pests/salt-freshwater/environmental-values-mapping.pdf](http://www.biosecurity.govt.nz/files/pests/salt-freshwater/environmental-values-mapping.pdf) (accessed 28 July 2014).
- Beaumont, J.; Oliver, M.; MacDiarmid, A. 2008: Mapping the values of New Zealand's coastal waters. 1. Environmental values. *Biosecurity New Zealand Technical Paper No: 2008/16*. Ministry of Agriculture and Forestry, Wellington, New Zealand. 73 p. [www.biosecurity.govt.nz/files/pests/salt-freshwater/mapping-coastal-waters.pdf](http://www.biosecurity.govt.nz/files/pests/salt-freshwater/mapping-coastal-waters.pdf) (accessed 28 July 2014).
- Bergin, D.O.; Kimberley, M.O. 2003: Growth and yield of totara in planted stands. *New Zealand Journal of Forestry Science* 33(2): 244–264.
- Bess, R. 2005: Expanding New Zealand's quota management system. *Marine Policy* 29: 339–347.
- Bianchi, F.J.J.A.; Booij, C.J.H.; Tschamtki, T. 2006: Sustainable pest regulation in agricultural landscapes: a review on landscape composition, biodiversity and natural pest control. *Proceedings of the Royal Society B: Biological Sciences* 273(1595): 1715–1727.
- Birding New Zealand 2012: New Zealand birding guide: your guide to the best birding tours, accommodation and locations in New Zealand. New Zealand Birding Network Incorporated, New Zealand. 56 p. [www.birdingnz.co.nz/files/dmfile/Bird-Directory.pdf](http://www.birdingnz.co.nz/files/dmfile/Bird-Directory.pdf) (accessed 31 July 2014).
- Blaschke, P. 2013: Health and wellbeing benefits of conservation in New Zealand. *Science for Conservation* 321. Department of Conservation, Wellington, New Zealand. 37 p.
- Blaschke, P.; Hicks, D.; Meister, A. 2008: Quantification of the flood and erosion reduction benefits, and costs, of climate change mitigation measures in New Zealand. Prepared by Blaschke and Rutherford Environmental Consultants for the Ministry for the Environment, Wellington, New Zealand. iv + 76 p. [www.mfe.govt.nz/publications/climate/quantification-flood-erosion-reduction-apr08/quantification-flood-erosion-reduction-apr08.pdf](http://www.mfe.govt.nz/publications/climate/quantification-flood-erosion-reduction-apr08/quantification-flood-erosion-reduction-apr08.pdf) (accessed 28 July 2014).
- Bloomberg, M.; Davies, T.; Visser, R.; Morgenroth, J. 2011: Erosion susceptibility classification and analysis of erosion risks for plantation forestry. Prepared by the University of Canterbury for the Ministry for the Environment, Wellington, New Zealand. 53 p. [www.mfe.govt.nz/sites/default/files/laws/standards/forestry/erosion-susceptibility-classification.pdf](http://www.mfe.govt.nz/sites/default/files/laws/standards/forestry/erosion-susceptibility-classification.pdf) (accessed 8 December 2014).
- Booth, K. 2012: Natural character in Hawke's Bay: application of the River Values Assessment System (RiVAS and RiVAS+). *LEaP Research Paper No. 15*. Lincoln University, Lincoln, New Zealand. 28 p.
- Booth, K.; Ballinger, J.; Blunden, G.; Farrow, G.; Glover, N.; Gregson, J.; Jones, D. 2013a: Natural character in Northland: application of the River Values Assessment System (RiVAS). *LEaP Research Paper No. 23*. Lincoln University, Lincoln, New Zealand. 19 p.
- Booth, K.; Ballinger, J.; Glover, N.; Greer, L.; Jones, D.; Lewis, G.; Mussle, R.; Paraone, T. 2013b: River swimming in Northland: application of the River Values Assessment System (RiVAS and RiVAS+). *LEaP Research Paper No. 22*. Lincoln University, Lincoln, New Zealand. 42 p.
- Booth, K.; Bellamy, S.; England, A.; Hales, W.; Kelly, B.; Mahoney, M.; Reed, C.; Sevicke-Jones, G. 2012a: Whitewater kayaking in Hawke's Bay: application of the River Values Assessment System (RiVAS). *LEaP Research Paper No. 12*. Lincoln University, Lincoln, New Zealand. 26 p.
- Booth, K.; Bull, S.; Callis, J.; Murphy, F.; Pitkethley, R. 2012b: Salmonid angling in the Gisborne District: application of the River Values Assessment System (RiVAS). *LEaP Research Paper No. 6*. Lincoln University, Lincoln, New Zealand. 26 p.

- Booth, K.; Callis, J.; Cave, H.; Fogle, S.; Gaddum, M.; Hudson, K.; Warmenhoven, T. 2012c: Natural character in the Gisborne District: application of the River Values Assessment System (RiVAS). *LEaP Research Paper No. 8*. Lincoln University, Lincoln, New Zealand. 21 p.
- Booth, K.; Callis, J.; Panton, T.; Sutherland, D. 2012d: River swimming in the Gisborne District: application of the River Values Assessment System (RiVAS). *LEaP Research Paper No. 7*. Lincoln University, Lincoln, New Zealand. 39 p.
- Booth, K.; Coubrough, L.; Winlove, T. 2012e: Salmonid angling in Hawke's Bay: application of the River Values Assessment System (RiVAS). *LEaP Research Paper No. 16*. Lincoln University, Lincoln, New Zealand. 34 p.
- Booth, K.; Madaraz-Smith, A.; Mauger, J.; Paipper, A.; Petuha, E.; Sharp, T. 2012f: Swimming in Hawke's Bay: application of the River Values Assessment System (RiVAS and RiVAS+). *LEaP Research Paper No. 17*. Lincoln University, Lincoln, New Zealand. 25 p.
- Booth, K.; Rutledge, M.; Tonkin, C.; West, D. 2013c: Whitebaiting: application of the River Values Assessment System (RiVAS). *LEaP Research Paper No. 24*. Lincoln University, Lincoln, New Zealand. 25 p.
- Bowden, D.A.; Compton, T.J.; Snelder, T.H.; Hewitt, J.E. 2011: Evaluation of the New Zealand Marine Environment Classifications using Ocean Survey 20/20 data from Chatham Rise and Challenger Plateau. *New Zealand Aquatic Environment and Biodiversity Report No. 77*. Ministry of Fisheries, Wellington, New Zealand. 27 p.
- Brabyn, L. n.d.: New Zealand Landscape Classification Version II—a classification of visual landscape character. University of Waikato, Hamilton, New Zealand. 42 p. [www.waikato.ac.nz/fass/about/staff/larsb/New-Zealand-Landscape-Classification-v2.1.pdf](http://www.waikato.ac.nz/fass/about/staff/larsb/New-Zealand-Landscape-Classification-v2.1.pdf) (accessed 11 September 2014).
- Brabyn, L. 1996a: Landscape classification using GIS and national digital databases. *Landscape Research 21*: 277–300.
- Brabyn, L. 1996b: Landscape classification using GIS and national digital databases. Unpublished PhD thesis in Geography, University of Canterbury, Christchurch, New Zealand. 256 p. <http://ir.canterbury.ac.nz/handle/10092/4892> (accessed 8 January 2014).
- Brabyn, L. 2009: Classifying landscape character. *Landscape Research 34*: 299–321.
- Brabyn, L. Sutton, S. 2013: A population based assessment of the geographical accessibility of outdoor recreation opportunities in New Zealand. *Applied Geography 41*: 124–131.
- Brabyn, M.W. 1991: An analysis of the New Zealand whale stranding record. *Science and Research Series No. 29*. Department of Conservation, Wellington, New Zealand. 47 p. <http://www.doc.govt.nz/Documents/science-and-technical/SR29.pdf> (accessed 3 November 2014).
- Brown, G.; Brabyn, L. 2012a: An analysis of the relationships between multiple values and physical landscapes at a regional scale using public participation GIS and landscape character classification. *Landscape and Urban Planning 107(3)*: 317–331.
- Brown, G.; Brabyn, L. 2012b: The extrapolation of social landscape values to a national level in New Zealand using landscape character classification. *Applied Geography 35*: 84–94.
- Brown, G.; Montag, J.M.; Lyon, K. 2012: Public participation GIS: a method for identifying ecosystem services. *Society and Natural Resources 25*: 633–651.
- Brown, S. 2010: Cultural landscapes. A practical guide for park management. Department of Environment, Climate Change and Water, New South Wales, Australia. 101 p.
- Bryan, B.A.; Raymond, C.M.; Crossman, N.D.; MacDonald, D.H. 2010: Targeting the management of ecosystem services based on social values: where, what, and how? *Landscape and Urban Planning 97*: 111–122.
- Bull, S.; Bassett, A.; Hughey, F.D. 2012: Native birdlife in Gisborne District: application of the River Values Assessment System (RiVAS and RiVAS+). *LEaP Research Paper No. 5*. Lincoln University, Lincoln, New Zealand. 20 p.
- Burkhard, B.; Kroll, F.; Nedkov, S.; Müller, F. 2012: Mapping ecosystem service supply, demand and budgets. *Ecological Economics 21*: 17–29.
- Butcher Partners Ltd 2004: Regional economic impacts of West Coast Conservation Land: final report. Prepared for the Department of Conservation, New Zealand. 28 p. [www.doc.govt.nz/Documents/conservation/threats-and-impacts/benefits-of-conservation/regional-economic-impacts-of-west-coast-conservation-land.pdf](http://www.doc.govt.nz/Documents/conservation/threats-and-impacts/benefits-of-conservation/regional-economic-impacts-of-west-coast-conservation-land.pdf) (accessed 28 May 2013).
- Butcher Partners Ltd 2005: Regional economic impacts of Abel Tasman National Park and Queen Charlotte Track. Prepared for the Department of Conservation, New Zealand. 25 p. [www.doc.govt.nz/Documents/conservation/threats-and-impacts/benefits-of-conservation/abel-tasman-and-queen-charlotte-report.pdf](http://www.doc.govt.nz/Documents/conservation/threats-and-impacts/benefits-of-conservation/abel-tasman-and-queen-charlotte-report.pdf) (accessed 28 July 2014).
- Butcher Partners Ltd 2006a: Economic benefits of water in Te Papanui Conservation Park. Inception report. Prepared for the Department of Conservation, New Zealand. 13 p.

- Butcher Partners Ltd 2006b: Regional economic impacts of Fiordland national park. Prepared for the Department of Conservation, New Zealand. 25 p. [www.doc.govt.nz/documents/conservation/threats-and-impacts/benefits-of-conservation/economic-impacts-fiordland.pdf](http://www.doc.govt.nz/documents/conservation/threats-and-impacts/benefits-of-conservation/economic-impacts-fiordland.pdf) (accessed 28 July 2014).
- Buxton, R.P.; Johnson, P.N.; Espie, P.R. 1996: Sphagnum research programme: the ecological effects of commercial harvesting. *Science for Conservation* 25. Department of Conservation, Wellington, New Zealand. 34 p.
- Cable, N.; Standley, A. 2012: Archaeological prediction for road asset management—State Highway 11 Northland. Prepared for the New Zealand Transport Agency by Opus International Consultants, Hamilton, New Zealand. 46 p. [www.nzta.govt.nz/network/operating/sustainably/docs/predictive-archaeological-modeling-report.pdf](http://www.nzta.govt.nz/network/operating/sustainably/docs/predictive-archaeological-modeling-report.pdf) (accessed 28 July 2014).
- Carrick, S.; Vesely E-T.; Hewitt A. 2010: Economic value of improved soil natural capital assessment: a case study on nitrogen leaching. 19th World Congress of Soil Science, Soil Solutions for a Changing World, 1–6 August 2010, Brisbane, Australia. Published on DVD. [www.iuss.org/19th%20WCSS/Symposium/pdf/4.1.1.pdf#page=11](http://www.iuss.org/19th%20WCSS/Symposium/pdf/4.1.1.pdf#page=11) (accessed 28 July 2014).
- Carswell, F.E.; Burrows, L.E.; Mason, N.W.H. 2009: Above-ground carbon sequestration by early-successional woody vegetation: a preliminary analysis. *Science for Conservation* 297. Department of Conservation, Wellington, New Zealand. 20 p.
- Carswell, F.E.; Easdale, T.A.; Overton, J.McC.; Ausseil, A.-G.E.; Greenaway, A.J.; Dymond, J.R.; Mason, N.W.H.; Arnst, E.A.; Burrows, L.E.; Herzig, A.; Price, R.; Holdaway, R.J.; Peltzer, D.A. 2013: St James Conservation Area: a purchase for ecosystem services. Pp. 524–537 in Dymond, J.R. (Ed.): Ecosystem services in New Zealand—conditions and trends. Manaaki Whenua Press, Lincoln, New Zealand.
- Casalegno, S.; Inger, R.; DeSilvey, C.; Gaston, K.J. 2013: Spatial covariance between aesthetic value and other ecosystem services. *PLoS ONE* 8(6): e68437. doi:10.1371/journal.pone.0068437.
- Chen, N.; Li, H.; Wang, L. 2009: A GIS-based approach for mapping direct use value of ecosystem services at a county scale: management implications. *Ecological Economics* 68: 2768–2776.
- Chmura, G.L.; Anisfeld, S.C.; Cahoon, D.R.; Lynch, J.C. 2003: Global carbon sequestration in tidal, saline wetland soils. *Global Biogeochemical Cycles* 17(4): 1111.
- Chrystall, C.; Patterson, M.; Cole, A.; Golubiewski, N. 2012: Economic value of ecosystem services in Ngāti Ruakawa kit e Tonga. *Ngā Māramatanga-a-Papa (Iwi Ecosystem Services) Research Monograph Series No. 6*. Massey University and Landcare Research/Manaaki Whenua, Palmerston North, New Zealand. 36 p.
- Church, A.; Fish, R.; Haines-Young, R.; Mourato, S.; Tratalos, J.; Stapleton, L.; Willis, C.; Coates, P.; Gibbons, S.; Leyshon, C.; Potschin, M.; Ravenscroft, N.; Sanchis-Guarner, R.; Winter, M.; Kenter, J. 2014: UK National Ecosystem Assessment Follow-on. Work Package Report 5: cultural ecosystem services and indicators. UNEP-WCMC, LWEC, UK. 135 p. [www.nottingham.ac.uk/cem/pdf/Church\\_et\\_al\\_2014\\_NEA\\_CES.pdf](http://www.nottingham.ac.uk/cem/pdf/Church_et_al_2014_NEA_CES.pdf) (accessed 17 December 2014).
- Clapcott, J.; West, D.; Goodman, J.; Goodwin, E.; Lander, R.; Lucas, J.; Crone, D.; Murphy, P.; Palmer, M.; Hughey, K.F.D. 2012: Native fish: development and application of the River Values Assessment System (RiVAS and RiVAS+) method to the Gisborne District Council region. *LEaP Research Paper No. 10*. Lincoln University, Lincoln, New Zealand. 32 p.
- Clark, D. 2014: Nelson Bays ecosystem map. *Cawthron Report No. 2498*. Prepared for the Ministry of Business, Innovation and Employment, New Zealand. 53 p.
- Clark, M.R.; Rowden, A.A.; Schlacher, T.; Williams, A.; Consalvey, M.; Stocks, K.I.; Rogers, A.D.; O'Hara, T.D.; White, M.; Shank, T.M.; Hall-Spencer, J.M. 2010: The ecology of seamounts: structure, function, and human impacts. *Annual Review of Marine Science* 2: 253–278.
- Clough, P. 2013: Recreation and tourism benefits of conservation investment: a way ahead for estimating and demonstrating value. New Zealand Institute of Economic Research contract report prepared for the Department of Conservation, New Zealand (unpublished). 34 p. (DOCDM-1452265)
- Cochran, C. 2011: Fowler's Hut, St James Station. Conservation report. Department of Conservation, New Zealand (unpublished). (DOCDM-1164068)
- Cochran, C. 2012: St James Station: woolshed, cook shop and stables. Conservation report. Department of Conservation, New Zealand (unpublished). 77 p. (DOCDM-998639)
- Cochran, C. 2013a: Lake Guyon Hut, St James Station. Maintenance plan. Department of Conservation, New Zealand (unpublished). 48 p. (DOCDM-1157741 or DOCDM-1157744)
- Cochran, C. 2013b: Stanley Vale Hut, St James Station. Conservation report. Department of Conservation, New Zealand (unpublished). 51 p. (DOCDM-1184103 or DOCDM-1184106)

- Coriolis 2012: Investment opportunities in the New Zealand honey industry. Part of the food and beverage information project prepared for the Ministry of Business, Innovation and Employment by Coriolis, Auckland, New Zealand. 68 p. [www.med.govt.nz/sectors-industries/food-beverage/pdf-docs-library/information-project/coriolis-report-investment-opportunities-honey-industry.pdf](http://www.med.govt.nz/sectors-industries/food-beverage/pdf-docs-library/information-project/coriolis-report-investment-opportunities-honey-industry.pdf) (accessed 3 May 2013).
- Costanza, R.; d'Arge, R.; de Groot, R.; Farber, S.; Grasso, M.; Hannon, B.; Limburg, K.; Naeem, S.; O'Neill, R.V.; Paruelo, J.; Raskin, R.G.; Sutton, P.; van den Belt, M. 1997: The value of the world's ecosystem services and natural capital. *Nature* 387: 253–260.
- Costanza, R.; de Groot, R.; Sutton, P.; van der Ploeg, S.; Anderson, S.L.; Kubiszewski, I.; Farber, S.; Turner, R.K. 2014: Changes in the global value of ecosystem services. *Global Environmental Change* 26: 152–158.
- Costanza, R.; Wilson, M.; Troy, A.; Voinov, A.; Lin, S.; Agostino, J.D. 2006: The value of New Jersey's ecosystem services and natural capital. Springer Science and Business Media, Netherlands and New York, USA. 167 p.
- Crossman, N.D.; Bryan, B.A. 2009: Identifying cost-effective hotspots for restoring natural capital and enhancing landscape multifunctionality. *Ecological Economics* 68: 654–668.
- Crossman, N.D.; Burkhard, B.; Nedkov, S.; Willemsen, L.; Petz, K.; Palomo, I.; Drakou, E.G.; Martin-Lopez, B.; McPhearson, T.; Boyanova, K.; Alkemade, R.; Egoh, B.; Dunbar, M.B.; Maes, J. 2013: A blueprint for mapping and modelling ecosystem services. *Ecosystem Services* 4: 4–14.
- Dahdouh-Guebas, F.; Jayatissa, L.P.; Di Nitto, D.; Bosire, J.O.; Lo Seen, D.; Koedam, N. 2005: How effective were mangroves as a defence against the recent tsunami? *Current Biology* 15(12): 443–447.
- Daily, G.C.; Kareiva, P.M.; Polasky, S.; Taylor, H.R.; Tallis, H. 2011: Mainstreaming natural capital into decisions. Pp. 3–14 in Kareiva, P.; Tallis, H.; Ricketts, T.H.; Daily, G.C.; Polasky, S. (Eds): *Natural capital: theory and practice of mapping ecosystem services*. Oxford University Press, New York, USA.
- Davies, K.K. 2012: Coastal ecosystem services: a participatory approach to modelling, management, and governance in Manukau Harbour. Unpublished PhD thesis research proposal, University of Auckland, Auckland, New Zealand.
- Davis, T.A.; O'Regan, T.; Wilson, J. 1990: Ngā tohu pūmahara: the survey pegs of the past: understanding Māori place names. New Zealand Geographic Board (Ngā Pou Taunaha o Aotearoa), Auckland, New Zealand. 48 p.
- de Groot, R.; Brander, L.; Van der Ploeg, S.; Costanza, R.; Bernard, F.; Braat, L.; Christie, M.; Crossman, N.; Ghermandi, A.; Hein, L.; Hussain, S.; Kumar, P.; McVittie, A.; Portela, R.; Rodriguez, L.C.; ten Brink, P.; van Beukering, P. 2012: Global estimates of the value of ecosystems and their services in monetary units. *Ecosystem Services* 1: 50–61.
- Dennis, A. 1998: St James Pastoral Lease. A report on proposals for protection and public access prepared for the Executive of Federated Mountain Clubs of New Zealand Inc. (unpublished). 26 p.
- DOC (Department of Conservation) n.d.: Procedure for revising visitor site scores and visitor groups. Department of Conservation, New Zealand (unpublished). 20 p. (OldDM-781190)
- DOC (Department of Conservation) 1996: Visitor Strategy. Department of Conservation, New Zealand (unpublished). 60 p. (DOCDM-395499)
- DOC (Department of Conservation) 2005: Conservation general policy. Department of Conservation, Wellington, New Zealand. 68 p.
- DOC (Department of Conservation) 2006: The value of conservation: what does conservation contribute to the economy? Department of Conservation, Wellington, New Zealand. 19 p. [www.doc.govt.nz/Documents/conservation/value-of-conservation.pdf](http://www.doc.govt.nz/Documents/conservation/value-of-conservation.pdf) (accessed 28 July 2014).
- DOC (Department of Conservation) 2010a: Historic heritage business processes & terminology. Version 2. Department of Conservation, New Zealand (unpublished). 28 p. (DOCDM-538289)
- DOC (Department of Conservation) 2010b: Historic into AMIS Project—instructions handout. Version 2.2, 13 August 2010. Department of Conservation, New Zealand (unpublished). 31 p. (DOCDM-617434)
- DOC (Department of Conservation) 2010c: New Zealand Coastal Policy Statement. Department of Conservation, Wellington, New Zealand. 28 p. [www.doc.govt.nz/documents/conservation/marine-and-coastal/coastal-management/nz-coastal-policy-statement-2010.pdf](http://www.doc.govt.nz/documents/conservation/marine-and-coastal/coastal-management/nz-coastal-policy-statement-2010.pdf) (accessed 18 September 2014).
- DOC (Department of Conservation) 2011: Destination Management Framework—a new approach to managing destinations. Department of Conservation, New Zealand. 19 p. [www.doc.govt.nz/Documents/about-doc/role/policies-and-plans/cms/dmf-overview.pdf](http://www.doc.govt.nz/Documents/about-doc/role/policies-and-plans/cms/dmf-overview.pdf) (accessed 28 April 2015).
- DOC (Department of Conservation) 2012a: Historic heritage references: definitions, abbreviations, legislation. Department of Conservation, New Zealand (unpublished). 10 p. (DOCDM-84556)

- DOC (Department of Conservation) 2012b: Statement of Intent 2012–2017. Department of Conservation, Wellington, New Zealand. 52 p. [www.doc.govt.nz/about-doc/role/corporate-publications/statement-of-intent-archive/statement-of-intent-2012-2017](http://www.doc.govt.nz/about-doc/role/corporate-publications/statement-of-intent-archive/statement-of-intent-2012-2017) (accessed 28 July 2014).
- DOC (Department of Conservation) 2013a: New Zealand bat monitoring data aggregation project factsheet, 25 March 2013. Department of Conservation, New Zealand (unpublished). 2 p. (DOCDM-1141968)
- DOC (Department of Conservation) 2013b: Statement of Intent 2013–2017. Department of Conservation, Wellington, New Zealand. 52 p. [www.doc.govt.nz/Documents/about-doc/statement-of-intent-2012-2017/statement-of-intent-2013-2017.pdf](http://www.doc.govt.nz/Documents/about-doc/statement-of-intent-2012-2017/statement-of-intent-2013-2017.pdf) (accessed 5 June 2013).
- DOC (Department of Conservation) 2014a: Natural Heritage Investment Strategy 2015–2019. October 2014. Department of Conservation, New Zealand (unpublished). 6 p. (DOCDM-1480311)
- DOC (Department of Conservation) 2014b: A review of the Destination Management Framework (2014). Department of Conservation, New Zealand (unpublished). 32 p. (DOCDM-1336153)
- DOC (Department of Conservation) 2014c: Statement of Intent 2014–2017. Department of Conservation, Wellington, New Zealand. 26 p. [www.doc.govt.nz/Documents/about-doc/role/publications/statement-of-intent-2014-2018.pdf](http://www.doc.govt.nz/Documents/about-doc/role/publications/statement-of-intent-2014-2018.pdf) (accessed 15 January 2015).
- DOC (Department of Conservation); MfE (Ministry for the Environment) 2000: The New Zealand Biodiversity Strategy. Department of Conservation and Ministry for the Environment, Wellington, New Zealand. 144 p.
- DOC (Department of Conservation); MFish (Ministry of Fisheries) 2008: Marine protected areas: classification, protection standard and implementation guidelines. Department of Conservation and Ministry of Fisheries, Wellington, New Zealand. 54 p. [www.doc.govt.nz/Documents/conservation/marine-and-coastal/marine-protected-areas/mpa-classification-protection-standard.pdf](http://www.doc.govt.nz/Documents/conservation/marine-and-coastal/marine-protected-areas/mpa-classification-protection-standard.pdf) (accessed 28 July 2014).
- DOC (Department of Conservation); MFish (Ministry of Fisheries) 2011: Coastal marine habitats and marine protected areas in the New Zealand Territorial Sea: a broad scale gap analysis. Department of Conservation and Ministry of Fisheries, Wellington, New Zealand. 50 p. [www.doc.govt.nz/Documents/conservation/marine-and-coastal/marine-protected-areas/coastal-marine-habitats-marine-protected-areas.pdf](http://www.doc.govt.nz/Documents/conservation/marine-and-coastal/marine-protected-areas/coastal-marine-habitats-marine-protected-areas.pdf) (accessed 28 July 2014).
- Dodd, A. 2006: Motukorea/Browns Island archaeological landscape—heritage assessment. Department of Conservation, Auckland, New Zealand. 20 p. [www.doc.govt.nz/Documents/conservation/historic/by-region/auckland/motukorea/motukorea-archaeological-landscape-full.pdf](http://www.doc.govt.nz/Documents/conservation/historic/by-region/auckland/motukorea/motukorea-archaeological-landscape-full.pdf) (accessed 8 January 2014).
- Dominati, E.; Patterson, M.; Mackay, A. 2010: A framework for classifying and quantifying the natural capital and ecosystem services of soils. *Ecological Economics* 69: 1858–1868.
- Donovan, B.J. 1980: Interactions between native and introduced bees in New Zealand. *New Zealand Journal of Ecology* 3: 104–116.
- Donovan, B.J. 2007: Apoidea (Insecta: Hymenoptera). *Fauna of New Zealand Ko te Aitanga Pepeke o Aotearoa* 57. Manaaki Whenua Press, Lincoln, New Zealand. 295 p.
- Donovan, B.J.; Howlett, B.G.; Walker, M.K. 2010: Relocation and establishment of nesting populations of the native bee *Leioproctus huakiwi* Donovan (Hymenoptera: Colletidae). *New Zealand Entomologist* 33: 109–113.
- Durie, M. 2004: An indigenous model of health promotion. 18th World Conference on Health Promotion and Health Education, 27 April 2004, Melbourne, Australia. 21 p.
- Dyanna Jolly Consulting 2009: Cultural values report: Takamatua to Takapūneke (Akaroa). Prepared at the request of Mahaanui Kurataiao Ltd for the Christchurch City Council, New Zealand. 34 p.
- Dymond, J.R.; Ausseil, A-G.; Ekanayake, J.; Kirschbaum, M.U.F. 2012: Tradeoffs between soil, water, and carbon—a national scale analysis from New Zealand. *Journal of Environmental Management* 95: 124–131.
- Dymond, J.R.; Ausseil, A-G.; Herzig, A. 2014: Downscaling ecosystem services to catchment scale—a case study in the Ruamahanga catchment. *Soil Horizons* 23: 10–11.
- Dymond, J.R.; Ausseil, A-G.; Herzig, A. 2014: Downscaling ecosystem services to catchment scale—a case study in the Ruamahanga catchment. *Soil Horizons* 23: 10–11.
- Dymond, J.R.; Ausseil, A-G.E.; Kirschbaum, M.U.F.; Carswell, F.E.; Mason, N.W.H. 2013a: Opportunities for restoring indigenous forest in New Zealand. *Journal of the Royal Society of New Zealand* 43(3): 141–153.
- Dymond, J.R.; Ausseil, A-G.E.; Parfitt, R.L.; Herzig, A.; McDowell, R.W. 2013b: Nitrate and phosphorus leaching in New Zealand: a national perspective. *New Zealand Journal of Agricultural Research* 56(1): 49–59.
- Dymond, J.R.; Ausseil, A-G.; Shepherd, J.D.; Buettner, L. 2006: Validation of a region-wide model of landslide susceptibility in the Manawatu-Wanganui region of New Zealand. *Geomorphology* 74: 70–79.

- Dymond, J.R.; Betts, H.D.; Schierlitz, C.S. 2010: An erosion model for evaluating regional land-use scenarios. *Environmental Modelling and Software* 25: 289–298.
- Dymond, J.R.; Shepherd, J.D. 2004: The spatial distribution of indigenous forest and its composition in the Wellington region, New Zealand, from ETM+ satellite imagery. *Remote Sensing of Environment* 90(1): 116–125.
- Egerton, R. n.d.: Historic and cultural heritage optimisation. Project initiation document and project plan. Department of Conservation, New Zealand (draft). (DOCDM-1147743)
- Egoh, B.; Drakou, E.G.; Dunbar, M.B.; Maes, J.; Willemen, L. 2012: Indicators for mapping ecosystem services: a review. *European Commission Report EUR 25456 EN*. Publications Office of the European Union, Luxembourg. 107 p.
- Egoh, B.; Reyers, B.; Rouget, M.; Bode, M.; Richardson, D.M. 2009: Spatial congruence between biodiversity and ecosystem services in South Africa. *Biological Conservation* 142: 553–562.
- Ellis, R.; Searle, R. 2013: An integrated water quality modelling framework for reporting on Great Barrier Reef catchments. Pp. 3183–3189 in Piantadosi, J.; Anderssen, R.S.; Boland J. (Eds): MODSIM2013, 20th International Congress on Modelling and Simulation. Modelling and Simulation Society of Australia and New Zealand, 1–6 December 2013, Adelaide, Australia. [www.mssanz.org.au/modsim2013/L21/ellis.pdf](http://www.mssanz.org.au/modsim2013/L21/ellis.pdf) (accessed 30 May 2014).
- Fahey, B.; Davie, T.; Stewart, M. 2011: The application of a water balance model to assess the role of fog in water yields from catchments in the east Otago uplands, South Island, New Zealand. *Journal of Hydrology (New Zealand)* 50(2): 279–292.
- Fahey, B.; Jackson, R.; Davie, T. 2004: User's guide for the land use change water balance model (WATYIELD). *Landcare Research Contract Report LCo203/185* prepared for the Ministry for the Environment, Wellington, New Zealand. 23 p. [http://icm.landcareresearch.co.nz/knowledgebase/publications/public/Watyield\\_Users\\_guide.pdf](http://icm.landcareresearch.co.nz/knowledgebase/publications/public/Watyield_Users_guide.pdf) (accessed 28 July 2014).
- Forster, M.E. 2012: Hei Whenua Papatipu: Kaitiakitanga and the politics of enhancing the mauri of wetlands. Unpublished PhD thesis in Māori Studies, Massey University, Palmerston North, New Zealand. 276 p. [http://mro.massey.ac.nz/bitstream/handle/10179/3336/02\\_whole.pdf?sequence=1](http://mro.massey.ac.nz/bitstream/handle/10179/3336/02_whole.pdf?sequence=1) (accessed 24 March 2014).
- Galbraith, L.M.; Burns, C.W. 2007: Linking land-use, water body type and water quality in southern New Zealand. *Landscape Ecology* 22: 231–241.
- Garibaldi, L.A.; Steffan-Dewenter, I.; Winfree, R.; Aizen, M.A.; Bommarco, R.; Cunningham, S.A.; Kremen, C.; Carvalheiro, L.G.; Harder, L.D.; Afik, O.; Bartomeus, I.; Benjamin, F.; Boreux, V.; Cariveau, D.; Chacoff, N.P.; Dudenhöffer, J.H.; Freitas, B.M.; Ghazoul, J.; Greenleaf, S.; Hipólito, J.; Holzschuh, A.; Howlett, B.; Isaacs, R.; Javorek, S.K.; Kennedy, C.M.; Krewenka, K.M.; Krishnan, S.; Mandelik, Y.; Mayfield, M.M.; Motzke, I.; Munyuli, T.; Nault, B.A.; Otieno, M.; Peterson, J.; Pisanty, G.; Potts, S.G.; Rader, R.; Ricketts, T.H.; Rundlöf, M.; Seymour, C.L.; Schüepp, C.; Szentgyörgyi, H.; Taki, H.; Tschamtkte, T.; Vergara, C.H.; Viana, B.F.; Wanger, T.C.; Westphal, C.; Williams, N.; Klein, A.M. 2013: Wild pollinators enhance fruit set of crops regardless of honey bee abundance. *Science* 339: 1608–1611.
- Gauvin, F-P. 2009: What is a deliberative process? Factsheet. *Publication Number 1193*. National Collaborating Centre for Healthy Public Policy, Québec, Canada. 3 p. [www.ncchpp.ca/docs/DeliberativeDoc1\\_EN\\_pdf.pdf](http://www.ncchpp.ca/docs/DeliberativeDoc1_EN_pdf.pdf) (accessed 18 December 2014).
- Ghermandi, A.; Nunes, P.A.L.D. 2013: A global map of coastal recreation values: results from a spatially explicit meta-analysis. *Ecological Economics* 86: 1–15.
- Giera, N.; Bell, B. 2009: Economic costs of pests to New Zealand. *MAF Biosecurity New Zealand Technical Paper No: 2009/31*. Prepared by Nimmo-Bell for the Ministry of Agriculture and Forestry, Wellington, New Zealand. 80 p. <http://www.biosecurity.govt.nz/files/pests/surv-mgmt/economic-costs-of-pests-to-new-zealand.pdf> (accessed 28 July 2014).
- Golubiewski, N. 2012: Defining a functional landscape for the geospatial identification of ecosystem services. *Ngā Māramatanga-a-Papa (Iwi Ecosystem Services) Research Monograph Series No. 8*. Massey University and Landcare Research/Manaaki Whenua, Palmerston North, New Zealand. 38 p.
- Grazuleviciute-Vileniske, I.; Matijosaitiene, I. 2010: Cultural heritage of roads and road landscapes: classification and insights of valuation. *Landscape Research* 35(4): 391–413.
- Hall, F.; Oyston, E.; Lonie, A.; Grose, M.; Brown, G. 2012: Identifying conservation values, park experiences, and development preferences in the Otago region of New Zealand: a summary of a public participation geographic information system study in the Otago region. Department of Conservation, Otago, New Zealand. 15 p. [www.doc.govt.nz/Documents/getting-involved/consultations/current-consultations/otago/ppgis-final-public-report-otago.pdf](http://www.doc.govt.nz/Documents/getting-involved/consultations/current-consultations/otago/ppgis-final-public-report-otago.pdf) (accessed 27 May 2013).

- Hamill, K. 2006: Snapshot of lake water quality in New Zealand. Prepared by Opus International Consultants for the Ministry for the Environment, Wellington, New Zealand. 53 p. <http://mfe.govt.nz/publications/ser/snapshot-lake-water-quality-nov06/snapshot-lake-water-quality-nov06.pdf> (accessed 28 November 2014).
- Harmsworth, G. 1998: Indigenous values and GIS: a method and a framework. *Indigenous Knowledge and Development Monitor. Netherlands Organisation for International Cooperation in Higher Education (Nuffic) 6(3)*.
- Harmsworth, G. 2002: Indigenous concepts, values and knowledge for sustainable development: New Zealand case studies. In: 7th Joint Conference: Preservation of Ancient Cultures and the Globalisation Scenario, 22–24 November 2002, School of Māori and Pacific Development & International Centre for Cultural Studies (ICCS), India. Te Whare Wanaanga o Waikato, University of Waikato, Hamilton, New Zealand. [www.landcareresearch.co.nz/publications/researchpubs/harmsworth\\_indigenous\\_concepts.pdf](http://www.landcareresearch.co.nz/publications/researchpubs/harmsworth_indigenous_concepts.pdf) (accessed 29 May 2013).
- Harmsworth, G.R.; Awatere, S. 2013: Indigenous Māori knowledge and perspectives of ecosystems. Pp. 274–286 in Dymond, J.R. (Ed.): *Ecosystem services in New Zealand—conditions and trends*. Manaaki Whenua Press, Lincoln, New Zealand.
- Harmsworth, G.; Park, M.; Walker, D. 2005: Report on the development and use of GIS for iwi and hapū: Motueka case study, Aotearoa-New Zealand. Landcare Research, New Zealand. 33 p. [www.landcareresearch.co.nz/\\_data/assets/pdf\\_file/0008/39968/Development\\_use\\_GIS\\_Motueka.pdf](http://www.landcareresearch.co.nz/_data/assets/pdf_file/0008/39968/Development_use_GIS_Motueka.pdf) (accessed 28 July 2014).
- Harris, S. 2012a: Irrigation in Gisborne District: application of the River Values Assessment System (RiVAS). *LEaP Research Paper No. 9*. Lincoln University, Lincoln, New Zealand. 11 p.
- Harris, S. 2012b: Irrigation in Hawke's Bay: application of the River Values Assessment System (RiVAS). *LEaP Research Paper No. 13*. Lincoln University, Lincoln, New Zealand. 15 p.
- Harrison Grierson Consultants Ltd; NZIER (New Zealand Institute of Economic Research) 2011: Freshwater Management National Policy Statement: section 32 evaluation. HG Document No. R001v9-WE130567-01. Prepared for the Ministry for the Environment, New Zealand. 118 p. [www.mfe.govt.nz/publications/rma/nps-freshwater-management-2011/docs/nps-freshwater-mgnt-section-32.pdf](http://www.mfe.govt.nz/publications/rma/nps-freshwater-management-2011/docs/nps-freshwater-mgnt-section-32.pdf) (accessed 8 August 2013).
- Hartley, L.J. 2012: Five-minute bird counts in New Zealand. *New Zealand Journal of Ecology 36*: 268–278.
- Hawke, D.J. 2003: Cadmium distribution and inventories at a pre-European seabird breeding site on agricultural land, Banks Peninsula, New Zealand. *Australian Journal of Soil Research 41*: 19–26.
- Hawke, D.J.; Holdaway, R.N.; Causer, J.E.; Ogden, S. 1999: Soil indicators of pre-European seabird breeding in New Zealand at sites identified by predator deposits. *Australian Journal of Soil Research 37*: 103–113.
- Hawke, D.J.; Newman, J. 2004: Inventories and elemental accumulation in peat soils of forested seabird breeding islands, southern New Zealand. *Australian Journal of Soil Research 42*: 45–48.
- Hebel, M. 1999: World-view as the emergent property of human value system. *Systems Research and Behavioral Science 16*: 253–261.
- Henderson, R.; Woods, R.; Singh, S.; Zammit, C. 2011: Surface water components of New Zealand's National Water Accounts, 1995–2010. *NIWA Client Report CHC2011-051* prepared for Statistics New Zealand. 45 p.
- Hermann, A.; Schleifer, S.; Wrška, T. 2011: The concept of ecosystem services regarding landscape research: a review. *Living Reviews in Landscape Research 5*: 1.
- Hernández-Morcillo, M.; Plieninger, T.; Bieling, C. 2013: An empirical review of cultural ecosystem service indicators. *Ecological Indicators 29*: 434–444.
- Hewitt, A.; Hedley, C.; Rosser, B. 2010: Evaluation of soil natural capital in two soilscape. 19th World Congress of Soil Science, Soil Solutions for a Changing World, 1–6 August 2010, Brisbane, Australia. Published on digital video disk (DVD). 34 p. [www.iuss.org/19th%20WCSS/Symposium/pdf/4.1.1.pdf#page=11](http://www.iuss.org/19th%20WCSS/Symposium/pdf/4.1.1.pdf#page=11) (accessed 8 January 2015).
- Hewitt, A.; Webb, T.; Dominati, E.; Hedley, C. 2012: Soil natural capital definition using land evaluation principles. Pp. 15–18 in Minasny, B.; Malone, B.P.; Bratney, A.B. (Eds): *Digital soil assessments and beyond*. Taylor and Francis Group, CRC Press, London, UK.
- Hewitt, J.E.; Wang, D.; Francis, M.; Lundquist, C.; Duffy, C. 2015: Evaluating demersal fish richness as a surrogate for epibenthic richness in management and conservation. *Diversity and Distributions*. doi: 10.1111/ddi.12336
- Higgs, P.; Koll, M.; Crone, D.; Robertson, J.; Wilcox-Taylor, K.; Duncan, B.; Hughey, K.F.D. 2012: 'Water used for domestic purposes' in Gisborne district: application of the River Values Assessment System (RiVAS and RiVAS+). *LEaP Research Paper No. 11*. Lincoln University, Lincoln, New Zealand. 30 p.
- Holdaway, R.J.; Wiser, S.K.; Williams, P.A. 2012: Status assessment of New Zealand's naturally uncommon ecosystems. *Conservation Biology 26(4)*: 619–629.



- Hooper, D.U.; Chapin, F.S.; Ewel, J.J.; Hector, A.; Inchausti, P.; Lavorel, S.; Lawton, J.H.; Lodge, D.M.; Loreau, M.; Naeem, S.; Schmid, B.; Setälä, H.; Symstad, A.J.; Vandermeer, J.; Wardle, D.A. 2005: Effects of biodiversity on ecosystem functioning: a consensus of current knowledge. *Ecological Monographs* 75: 3–35.
- Howlett, B.G.; Walker, M.K.; Newstrom-Lloyd, L.E.; Donovan, B.J.; Teulon, D.A.J. 2009: Window traps and direct observations record similar arthropod flower visitor assemblages in two mass flowering crops. *Journal of Applied Entomology* 133: 533–564.
- Howlett, B.G.; Walker, M.K.; Rader, R.; Butler, R.C.; Newstrom-Lloyd, L.E.; Teulon, D.A.J. 2011: Can insect body pollen counts be used to estimate pollen deposition on pak choi stigmas? *New Zealand Plant Protection* 64: 25–31.
- Hughey, K.; Cameron, F.; Cheyne, J.; Dickson, R.; Forbes, A.; Hashiba, K.; Rook, H.; Sharp, T.; Stephenson, B.; Welch, B. 2012: Native birdlife in Hawke's Bay: application of the River Values Assessment System (RiVAS and RiVAS+). *LEaP Research Paper No. 14*. Lincoln University, Lincoln, New Zealand. 18 p.
- Hughey, K.F.D.; Baker, M.A. (Eds) 2010a: The River Values Assessment System: volume 1: overview of the method, guidelines for use and application to recreational values. *LEaP Report No. 24A*. Lincoln University, Lincoln, New Zealand. 182 p. [www.envirolink.govt.nz/PageFiles/31/Leap%2024A-The-River-Values-Assessment-System-Vol-1.pdf](http://www.envirolink.govt.nz/PageFiles/31/Leap%2024A-The-River-Values-Assessment-System-Vol-1.pdf) (accessed 31 July 2014).
- Hughey, K.F.D.; Baker, M.A. (Eds) 2010b: The River Values Assessment System: volume 2: application to cultural, production and environmental values. *LEaP Report No. 24B*. Lincoln University, Lincoln, New Zealand. 124 p. [www.envirolink.govt.nz/PageFiles/31/Leap%2024B-The-River-Values-Assessment-System-Vol-2.pdf](http://www.envirolink.govt.nz/PageFiles/31/Leap%2024B-The-River-Values-Assessment-System-Vol-2.pdf) (accessed 31 July 2014).
- Hughey, K.F.D.; Booth, K.L. 2012: Monitoring the state of New Zealand rivers: how the River Values Assessment System can help. *New Zealand Journal of Marine and Freshwater Research* 46(4): 545–556.
- Hughey, K.F.D.; Goodwin, E.; Burkepile, N.; Glover, N.; Griffin, B.; Hawkins, K.; Jones, K.; McGlynn, M.; Nicholson, C.; Poynter, M. 2013: Native fish in Northland: application of the River Values Assessment System (RiVAS and RiVAS+). *LEaP Research Paper No. 20*. Lincoln University, Lincoln, New Zealand. 38 p.
- Hume, T.M.; Snelder, T.; Weatherhead, M.; Liefing, R. 2007: A controlling factor approach to estuary classification. *Ocean and Coastal Management* 50: 905–929.
- Hunt, L. 2008: Economic impact analysis of the Cape Rodney Okakari Point (Leigh) Marine Reserve on the Rodney District. Department of Conservation investigation number 4052. Prepared for the Department of Conservation, New Zealand. 42 p. [www.marinenz.org.nz/documents/leigh\\_eco\\_impact.pdf](http://www.marinenz.org.nz/documents/leigh_eco_impact.pdf) (accessed 31 July 2014).
- Ingraham, N.L.; Mark, A.F. 2000: Isotopic assessment of the hydrologic importance of fog deposition on tall snow tussock grass on southern New Zealand uplands. *Austral Ecology* 25: 402–408.
- Jackson, B.; Pagella, T.; Sinclair, F.; Orellana, B.; Henshaw, A.; Reynolds, B.; McIntyre, N.; Wheeler, H.; Eycott, A. 2013: Polyscape: a GIS mapping framework providing efficient and spatially explicit landscape-scale valuation of multiple ecosystem services. *Landscape and Urban Planning* 112: 74–86.
- Jansen, A. 2005: Avian use of restoration plantings along a creek linking rainforest patches on the Atherton Tablelands, North Queensland. *Restoration Ecology* 13(2): 275–283.
- Johnson, T. 2009: Are tree-based carbon offsets beneficial? Chapter overview. Pp. 114–121 in Miller, D.A. (Ed.): Carbon offsets. Current Controversies Series. Greenhaven Press, Detroit, USA.
- Jonsson, M.; Buckley, H.L.; Case, B.S.; Wratten, S.D.; Hale, R.J.; Didham, R.K. 2012: Agricultural intensification drives landscape-context effects on host–parasitoid interactions in agroecosystems. *Journal of Applied Ecology* 49: 706–714.
- Jonsson, M.; Wratten, S.D.; Landis, D.A.; Tompkins, J.-A.L.; Cullen, R. 2010: Habitat manipulation to mitigate the impacts of invasive arthropod pests. *Biological Invasions* 12: 2933–2945.
- Joyce, K.; Sutton, S. 2009: A method for automatic generation of the Recreation Opportunity Spectrum in New Zealand. *Applied Geography* 29: 409–418.
- Kappers, B.; Smith, L. 2009: New Zealand Biodiversity Data Inventory (BDI) 2007. Summary report. Methodology, results and future—August 2009. Department of Conservation, New Zealand (unpublished). 11 p. (DOCDM-470898)
- Kareiva, P.; Tallis, H.; Ricketts, T.H.; Daily, G.C.; Polasky, S. (Eds) 2011: Natural capital: theory and practice of mapping ecosystem services. Oxford University Press, New York, USA. 365 p.
- Keiha, P.; Moon, P. 2008: The emergence and evolution of urban Māori authorities: a response to Māori urbanisation. *Te Kaharoa* 1(1): 1–17.

- Kenter, J.O. 2014: Deliberative and non-monetary valuation: a review of methods. Working Paper. Laurence Mee Centre for People and the Sea, Scottish Association for Marine Science, UK. 43 p. [www.sams.ac.uk/lmc/working-papers/kenter-valuation-review](http://www.sams.ac.uk/lmc/working-papers/kenter-valuation-review) (accessed 18 December 2014).
- King, N.J.; Lake, R.J.; Kerr, G.N. 2013: Wild foods. Pp. 287–299 in Dymond, J.R. (Ed.): *Ecosystem services in New Zealand—conditions and trends*. Manaaki Whenua Press, Lincoln, New Zealand.
- Kitson, J.C. 2004: Harvest rate of sooty shearwaters (*Puffinus griseus*) by Rakiura Māori: a potential tool to monitor population trends? *Wildlife Research* 31: 319–325.
- Kross, S.M.; Tylanakis, J.M.; Nelson, X.J. 2012: Effects of introducing threatened falcons into vineyards on abundance of passeriformes and bird damage to grapes. *Conservation Biology* 26(1): 142–149.
- Krupa, V. 1996: Nature in Māori metaphor. *Asian and African Studies* 5: 14–27.
- Landis, D.A.; Wratten, S.D.; Gurr, G.M. 2000: Habitat management to conserve natural enemies of arthropod pests in agriculture. *Annual Review of Entomology* 45: 175–201.
- Leathwick, J.; Dey, K.; Julian, K. 2006a: Development of a marine environmental classification optimised for demersal fish. *NIWA Client Report HAM2006-063* prepared for the Department of Conservation by the National Institute of Water and Atmospheric Research Ltd (NIWA), Hamilton, New Zealand. 18 p. [www.biodiversity.govt.nz/pdfs/seas/doc06213\\_env\\_classification%20final.pdf](http://www.biodiversity.govt.nz/pdfs/seas/doc06213_env_classification%20final.pdf) (accessed 31 July 2014).
- Leathwick, J.; Francis, M.; Julian, K. 2006b: Development of a demersal fish community classification for New Zealand's Exclusive Economic Zone. *NIWA Client Report HAM2006-062* prepared for the Department of Conservation by the National Institute of Water and Atmospheric Research Ltd (NIWA), Hamilton, New Zealand. 35 p. [www.biodiversity.govt.nz/pdfs/seas/DOC06213\\_fish\\_classification.pdf](http://www.biodiversity.govt.nz/pdfs/seas/DOC06213_fish_classification.pdf) (accessed 31 May 2013).
- Leathwick, J.; Morgan, F.; Wilson, G.; Rutledge, D.; McLeod, M.; Johnson, K. 2002: Land Environments of New Zealand: a technical guide. Ministry for the Environment, New Zealand. 237 p. [www.landcareresearch.co.nz/\\_data/assets/pdf\\_file/0020/21773/LENZ\\_Technical\\_Guide.pdf](http://www.landcareresearch.co.nz/_data/assets/pdf_file/0020/21773/LENZ_Technical_Guide.pdf) (accessed 31 July 2014).
- Leathwick, J.; Wright, E. 2011: Towards a vision for the optimisation of ecosystem management in New Zealand—core concepts, definitions and practicalities—21 June 2011. Department of Conservation, New Zealand (unpublished). 23 p. (DOCDM-736661)
- Leathwick, J.; Wright, E.; Cox, A. 2012a: Prioritisation of ecosystem management—June 2012. Department of Conservation, New Zealand (unpublished). 34 p. (DOCDM-992921)
- Leathwick, J.R.; Moilanen, A.; Ferrier, S.; Julian, K. 2010a: Complementarity-based conservation prioritization using a community classification, and its application to riverine ecosystems. *Biological Conservation* 143: 984–991.
- Leathwick, J.R.; Rowden, A.; Nodder, S.; Gorman, R.; Bardsley, S.; Pinkerton, M.; Baird, S.J.; Hadfield, M.; Currie, K.; Goh, A. 2012b: A Benthic-optimised Marine Environment Classification (BOMEC) for New Zealand waters. *New Zealand Aquatic Environment and Biodiversity Report No. 89*. Ministry of Fisheries, Wellington, New Zealand. 54 p. [http://ndhadeliver.natlib.govt.nz/delivery/DeliveryManagerServlet?dps\\_pid=IE13670068&dps\\_custom\\_att\\_1=ilsdb](http://ndhadeliver.natlib.govt.nz/delivery/DeliveryManagerServlet?dps_pid=IE13670068&dps_custom_att_1=ilsdb) (accessed 18 March 2013).
- Leathwick, J.R.; West, D.; Gerbeaux, P.; Kelly, D.; Robertson, H.; Brown, D.; Chadderton, W.L.; Ausseil, A-G. 2010b: Freshwater Ecosystems of New Zealand (FENZ) geodatabase: version one—August 2010—user guide. Department of Conservation, New Zealand. 51 p.
- Leathwick, J.R.; Wilson, G.H.; Rutledge, D.; Wardle, P.; Morgan, F.J.; Johnson, K.; McLeod, M.; Kirkpatrick, R. 2003: Land Environments of New Zealand: Nga Taiao o Aotearoa. Batemans, Auckland, New Zealand. 184 p.
- Lee, W.; McGlone, M.; Wright, E. 2005: Biodiversity inventory and monitoring: a review of national and international systems and a proposed framework for future biodiversity monitoring by the Department of Conservation. *Landcare Research Contract Report LC0405/122* prepared for the Department of Conservation. Manaaki Whenua Press, New Zealand. 213 p. [www.landcareresearch.co.nz/publications/researchpubs/biodiv\\_inventory\\_system\\_review\\_framework.pdf](http://www.landcareresearch.co.nz/publications/researchpubs/biodiv_inventory_system_review_framework.pdf) (accessed 20 April 2015).
- Lincoln Environmental 2000: Information on water allocation in New Zealand. *Lincoln Environmental Report No. 4375*/ prepared for the Ministry for the Environment, New Zealand. 190 p. [www.mfe.govt.nz/publications/water/water-allocation-apr00.pdf](http://www.mfe.govt.nz/publications/water/water-allocation-apr00.pdf) (accessed 31 March 2014).
- Liu, S.; Costanza, R.; Troy, A.; D'aagostino J.; Mates, W. 2010: Valuing New Jersey's ecosystem services and natural capital: a spatially explicit benefit transfer approach. *Environmental Management* 45: 1271–1285.
- Lock, K.; Leslie, S. 2007: New Zealand's Quota Management System: a history of the first 20 years. *Motu Working Paper 07-02* prepared for the Ministry of Fisheries. Motu Economic and Public Policy Research, Wellington,

- New Zealand. [www.fish.govt.nz/en-nz/Commercial/Quota+Management+System/Full+QMS+Details/default.htm](http://www.fish.govt.nz/en-nz/Commercial/Quota+Management+System/Full+QMS+Details/default.htm) (accessed 15 April 2015).
- Lonsdorf, E.; Ricketts, T.; Kremen, C.; Winfree, R.; Greenleaf, S.; Williams, N. 2011: Crop pollination services. Pp. 150–167 in Kareiva, P.; Tallis, H.; Ricketts, T.H.; Daily, G.C.; Polasky, S. (Eds): *Natural capital: theory and practice of mapping ecosystem services*. Oxford University Press, New York, USA.
- Lovelock, B.; Farminer, A.; Reis, A.C. 2011a: A bibliography of research on visitors to public conservation areas in New Zealand 1995–2010. Department of Conservation, Wellington, New Zealand. 85 p.
- Lovelock, B.; Farminer, A.; Reis, A.C. 2011b: A synthesis and gap analysis of research on visitors to public conservation areas in New Zealand 1995–2010. Department of Conservation, Wellington, New Zealand. 17 p.
- MA (Millennium Ecosystem Assessment) 2003: *Ecosystems and human well-being: a framework for assessment*. Island Press, Washington, DC, USA. 222 p.
- MA (Millennium Ecosystem Assessment) 2005: *Ecosystems and human well-being: synthesis*. Island Press, Washington, DC, USA. 137 p.
- MacDiarmid, A.; McKenzie, A.; Sturman, J.; Beaumont, J.; Mikaloff-Fletcher, S.; Dunne, J. 2012: Assessment of anthropogenic threats to New Zealand marine habitats. *New Zealand Aquatic Environment and Biodiversity Report No. 93*. Ministry of Agriculture and Forestry, Wellington, New Zealand. 225 p. [http://fs.fish.govt.nz/Doc/22981/AEBR\\_93.pdf.ashx](http://fs.fish.govt.nz/Doc/22981/AEBR_93.pdf.ashx) (accessed 31 July 2014).
- MacDiarmid, A.; Oliver, M.; Beaumont, J. 2008: Environmental value mapping. Supplementary information to MAF Biosecurity New Zealand Technical Paper 2008/16. Ministry of Agriculture and Forestry, Wellington, New Zealand. 26 p. [www.biosecurity.govt.nz/files/pests/salt-freshwater/environmental-value-mapping.pdf](http://www.biosecurity.govt.nz/files/pests/salt-freshwater/environmental-value-mapping.pdf) (accessed 28 July 2014).
- MacDiarmid, A.; Taylor, P.; Carbines, M.; Hewitt, J.; Bolton-Richie, L.; Maharadz-Smith, A.; Townsend, M.; Thrush, S.; Walker, J. 2011: Marine Habitat Assessment Decision Support (MarHADS) Tool—background and operating instructions. Project ELF09240. Prepared for the New Zealand Regional Council Coastal Special Interest Group (Coastal SIG) by National Institute of Water and Atmospheric Research (NIWA), New Zealand. 36 p. [www.envirolink.govt.nz/PageFiles/31/Marine%20Habitat%20Assessment%20Decision%20Support%20Tool%20-%20background%20and%20operating%20instructions.pdf](http://www.envirolink.govt.nz/PageFiles/31/Marine%20Habitat%20Assessment%20Decision%20Support%20Tool%20-%20background%20and%20operating%20instructions.pdf) (accessed 31 July 2014).
- MacDiarmid, A.B.; Law, C.S.; Pinkerton, M.; Zeldis, J. 2013: New Zealand marine ecosystem services. Pp. 238–253 in Dymond, J.R. (Ed.): *Ecosystem services in New Zealand—conditions and trends*. Manaaki Whenua Press, Lincoln, New Zealand.
- Mackay, K.A. 2006: Database documentation: seamount. National Institute of Water and Atmospheric Research (NIWA), New Zealand (internal report). 42 p. [www.fish.govt.nz/NR/rdonlyres/1F5E6461-8FE9-49B8-BECB-384D56DF6C9E/o/seamount.pdf](http://www.fish.govt.nz/NR/rdonlyres/1F5E6461-8FE9-49B8-BECB-384D56DF6C9E/o/seamount.pdf) (accessed 31 July 2014).
- Maes, J.; Egoh, B.; Willemsen, L.; Liqueste, C.; Vihervaara, P.; Schägner, J.P.; Grizzetti, B.; Drakou, E.G.; Notte, A.L.; Zulian, G.; Bouraoui, F.; Luisa Paracchini, M.; Braat, L.; Bidoglio, G. 2012: Mapping ecosystem services for policy support and decision making in the European Union. *Ecosystem Services* 1: 31–39.
- Maes, J.; Teller, A.; Erhard, M.; Liqueste, C.; Braat, L.; Berry, P.; Egoh, B.; Puydarrieux, P.; Fiorina, C.; Santos, F.; Paracchini, M.L.; Keune, H.; Wittmer, H.; Hauck, J.; Fiala, I.; Verburg, P.H.; Condé, S.; Schägner, J.P.; San Miguel, J.; Estreguil, C.; Ostermann, O.; Barredo, J.I.; Pereira, H.M.; Stott, A.; Laporte, V.; Meiner, A.; Olah, B.; Royo Gelabert, E.; Spyropoulou, R.; Petersen, J.E.; Maguire, C.; Zal, N.; Achilleos, E.; Rubin, A.; Ledoux, L.; Brown, C.; Raes, C.; Jacobs, S.; Vandewalle, M.; Connor, D.; Bidoglio, G. 2013: Mapping and assessment of ecosystems and their services. An analytical framework for ecosystem assessments under action 5 of the EU biodiversity strategy to 2020. Publications Office of the European Union, Luxembourg. 57 p. [http://ec.europa.eu/environment/nature/knowledge/ecosystem\\_assessment/pdf/MAESWorkingPaper2013.pdf](http://ec.europa.eu/environment/nature/knowledge/ecosystem_assessment/pdf/MAESWorkingPaper2013.pdf) (accessed 28 July 2014).
- MAF (Ministry of Agriculture and Forestry) 2000: Varroa in New Zealand: economic impact assessment. MAF Policy, New Zealand. 24 p. [www.biosecurity.govt.nz/files/pests/varroa/assessment.pdf](http://www.biosecurity.govt.nz/files/pests/varroa/assessment.pdf) (accessed 18 March 2014).
- Malone, L.A. 2002: Literature review on genetically modified plants and bee products. *MAF Technical Paper No. 2002/05. HortResearch Client Report No. 2002/440* prepared for MAF Policy by HortResearch, New Zealand. 47 p.
- Mark, A.F.; Dickinson, K.J.M. 2008: Maximising water yield with indigenous non-forest vegetation: a New Zealand perspective. *Frontiers in Ecology and the Environment* 6(1): 25–34.
- Marsden, M. 1988: The natural world and natural resources. Māori value systems and perspectives. *Resource Management Law Reform Working paper 29. Part A*. Ministry for the Environment, Wellington, New Zealand.
- Martínez-Harms, M.J.; Balvanera, P. 2012: Methods for mapping ecosystem supply: a review. *International Journal of Biodiversity Science, Ecosystem Services & Management* 8: 17–25.

- Mason, N.W.H.; Carswell, F.E.; Overton, J.McC.; Briggs, C.M.; Hall, G.M.J. 2012: Estimation of current and potential carbon stocks and Kyoto-compliant carbon gain on conservation land. *Science for Conservation* 317. Department of Conservation, Wellington, New Zealand. 39 p.
- McAlpine, K.G.; Wotton, D.M. 2009: Conservation and the delivery of ecosystem services: a literature review. *Science for Conservation* 295. Department of Conservation, Wellington, New Zealand. 81 p.
- McCallum-Clark, M.; Hardy, R.; Hunt, M. 2006: Transportation and noise: land use planning options for a quieter New Zealand. *Land Transport New Zealand Research Report* 299. Land Transport New Zealand, Wellington, New Zealand. 147 p.
- McDowall, R.M. 1976: The role of estuaries in the life cycles of fishes in New Zealand. *Proceedings of the New Zealand Ecological Society* 23: 27–32.
- McDowall, R.M. 2011: *Ikawai: freshwater fishes in Māori culture and economy*. Canterbury University Press, Christchurch, New Zealand. 832 p.
- McEntee, C. 2009: Spatial information not being exploited—report. *The Dominion Post*, 26 August 2009: C5.
- McLaughlin, D.L.; Cohen, M.J. 2013: Realising ecosystem services: wetland hydrologic function along a gradient of ecosystem condition. *Ecological Applications* 23: 1619–1631.
- McLay, C.L. 1976: An inventory of the status and origin of New Zealand estuarine systems. *Proceedings of the New Zealand Ecological Society* 23: 8–26.
- Mendoza, G.; Ennaanay, D.; Conte, M.; Walter, M.T.; Freyberg, D.; Wolny, S.; Hay, L.; White, S.; Nelson, E.; Solorzano, L. 2011: Water supply as an ecosystem service for hydropower and irrigation. Pp. 53–72 in Kareiva, P.; Tallis, H.; Ricketts, T.H.; Daily, G.C.; Polasky, S. (Eds): *Natural capital: theory and practice of mapping ecosystem services*. Oxford University Press, New York, USA.
- Mesa, L.A.; Howlett, B.G.; Grant, J.E.; Didham, R.K. 2013: Changes in the relative abundance and movement of insect pollinators during the flowering cycle of *Brassica rapa* crops: implications for gene flow. *Journal of Insect Science* 13(13): 1536–2442.
- Meurk, C.D.; Watts, R.H.; Swaffield, S.R.; Awatere, S. 2012: A natural environment and cultural asset management system for New Zealand's state highway network: towards a practical concept and application: November 2012. *New Zealand Transport Agency Research Report* 503. New Zealand Transport Agency, Wellington, New Zealand. 76 p. [www.nzta.govt.nz/resources/research/reports/503/docs/503.pdf](http://www.nzta.govt.nz/resources/research/reports/503/docs/503.pdf) (accessed 31 July 2014).
- MfE (Ministry for the Environment) 2004a: Water bodies of national importance: potential waters bodies of national importance for recreation value. Ministry for the Environment, Wellington, New Zealand. 25 p. <http://www.mfe.govt.nz/sites/default/files/national-importance-rec-dec04.pdf> (accessed 1 December 2014).
- MfE (Ministry for the Environment) 2004b: Water programme of action: potential water bodies of national importance. Technical Working Paper. Ministry for the Environment, Wellington, New Zealand. 38 p. [www.mfe.govt.nz/sites/default/files/national-importance-julo4.pdf](http://www.mfe.govt.nz/sites/default/files/national-importance-julo4.pdf) (accessed 1 December 2014).
- MfE (Ministry for the Environment) 2011: Measuring and reporting water takes. An introduction to the Resource Management (Measuring and Reporting of Water Takes) Regulations 2010. *INFO 617*. Ministry for the Environment, Wellington, New Zealand. [www.mfe.govt.nz/sites/default/files/measuring-and-reporting-water-takes.pdf](http://www.mfe.govt.nz/sites/default/files/measuring-and-reporting-water-takes.pdf) (accessed 30 April 2015).
- MfE (Ministry for the Environment) 2012: Land-use and carbon analysis system: satellite imagery interpretation guide for land-use classes (2nd edition). Ministry for the Environment, Wellington, New Zealand. 71 p. <http://mfe.govt.nz/publications/climate/satellite-imagery-interpretation-guide/satellite-imagery-interpretation-guide.pdf> (accessed 19 March 2015).
- MFish (Ministry of Fisheries) 2011: New Zealand's sustainable fisheries. *Sustainable New Zealand Seafood, October 2011*. Ministry of Fisheries, New Zealand. 2 p. [www.fish.govt.nz/NR/rdonlyres/FDA16ECD-CF21-40DB-9748-F2942CoEFEF2/0/General2011v3.pdf](http://www.fish.govt.nz/NR/rdonlyres/FDA16ECD-CF21-40DB-9748-F2942CoEFEF2/0/General2011v3.pdf) (accessed 10 September 2013).
- Milcu, A.J.; Hanspach, J.; Abson, D.; Fischer, J. 2013: Cultural ecosystem services: a literature review and prospects for future research. *Ecology and Society* 18(3): 44.
- Ministry for Culture and Heritage 2009: How important is culture? New Zealanders' views in 2008—an overview. Ministry for Culture and Heritage, Wellington, New Zealand. 20 p. [www.mch.govt.nz/files/HowImportantIsCulture.pdf](http://www.mch.govt.nz/files/HowImportantIsCulture.pdf) (accessed 27 May 2013).
- Ministry of Tourism 2009: Tourist activity: nature-based tourism. Tourism sector profile. August 2009. Ministry of Tourism, New Zealand. 4 p. [www.med.govt.nz/sectors-industries/tourism/pdf-docs-library/tourism-research-and-data/other-research-and-reports/tourism-sector-profiles/tourist-activity-profile/naturebasedtourism2009.pdf](http://www.med.govt.nz/sectors-industries/tourism/pdf-docs-library/tourism-research-and-data/other-research-and-reports/tourism-sector-profiles/tourist-activity-profile/naturebasedtourism2009.pdf) (accessed 8 January 2014).

- Mobius Research and Strategy Ltd. 2014: Identifying public perceptions for the management of iconic species, places and local treasures. Research report prepared for the Department of Conservation by Mobius Research and Strategy Ltd., New Zealand. 29 p. [www.doc.govt.nz/Documents/about-doc/policies-and-plans/public-expectations-management-iconic-species-places-local-treasures.pdf](http://www.doc.govt.nz/Documents/about-doc/policies-and-plans/public-expectations-management-iconic-species-places-local-treasures.pdf) (accessed 11 June 2015).
- Morato, T.; Hoyle, S.D.; Allain, V.; Nicol, S.J. 2010: Seamounts are hotspots of pelagic biodiversity in the open ocean. *Proceedings of the National Academy of Sciences (PNAS)* 107(21): 9707–9711.
- Morgan, T.K.K.B. 2006: Decision-support tools and the indigenous paradigm. *Engineering and Sustainability* 159: 169–177.
- MPI (Ministry for Primary Industries) 2012: Apiculture. Horticulture Monitoring 2012. Ministry for Primary Industries, Wellington, New Zealand. 9 p. [www.mpi.govt.nz/document-vault/4224](http://www.mpi.govt.nz/document-vault/4224) (accessed 9 June 2015).
- Nelson, E.J.; Kareiva, P.; Ruckelshaus, M.; Arkema, K.; Geller, G.; Girvetz, E.; Goodrich, D.; Matzek, V.; Pinsky, M.; Reid, W.; Saunders, M.; Semmens, D.; Tallis, H. 2013: Climate change's impact on key ecosystem services and the human well-being they support in the US. *Frontiers in Ecology and the Environment* 11(9): 483–493.
- Newsome, P.F.J. 1987: The vegetative cover of New Zealand. *Water and Soil Miscellaneous Publication No. 112*. Published for the National Water and Soil Conservation Authority by the Water and Soil Directorate, Ministry of Works and Development, Wellington, New Zealand. 153 p.
- Newstrom, L.; Robertson, A. 2005: Progress in understanding pollination systems in New Zealand. *New Zealand Journal of Botany* 43: 1–59.
- Newstrom-Lloyd, L.E. 2013: Pollination in New Zealand. Pp. 408–431 in Dymond, J.R. (Ed.): *Ecosystem services in New Zealand—conditions and trends*. Manaaki Whenua Press, Lincoln, New Zealand.
- New Zealand Tourism 2012: Visitor Experience Monitor 2011/2012. [www.tourismnewzealand.com/markets-and-stats/research/visitor-experience-monitor-201112](http://www.tourismnewzealand.com/markets-and-stats/research/visitor-experience-monitor-201112) (accessed 7 May 2014).
- New Zealand Wine Growers 2013: New Zealand Wine Growers annual report. New Zealand Wine, New Zealand. 32 p. [www.nzwine.com/assets/sm/upload/da/gi/te/eu/NZW\\_Annual\\_Report\\_2013\\_web.pdf](http://www.nzwine.com/assets/sm/upload/da/gi/te/eu/NZW_Annual_Report_2013_web.pdf) (accessed 25 September 2013).
- NZTRI (New Zealand Tourism Research Institute) 2000: The local economic impact of the Mount Hutt Ski Area. Ski Areas Association of New Zealand (SAANZ) research report, March 2000. New Zealand Tourism Research Institute. 59 p. <http://nztri.org/sites/default/files/MtHuttSAANZFinalReport.pdf> (accessed 31 July 2014).
- NZTRI (New Zealand Tourism Research Institute) 2002: Mount Ruapehu ski-fields: an economic impact study. New Zealand Tourism Research Institute report prepared for the Ski Areas Association of New Zealand by the Auckland University of Technology, Auckland, New Zealand. 45 p. [www.nztri.org/sites/default/files/RuapehuSkiReport.pdf](http://www.nztri.org/sites/default/files/RuapehuSkiReport.pdf) (accessed 31 July 2014).
- NZTRI (New Zealand Tourism Research Institute) 2005: The economic significance of the Southern Lakes Ski Areas—2005 Winter Season. New Zealand Tourism Research Institute report prepared for New Zealand Trade and Enterprise and the Southern Lakes Ski Areas. 75 p. [www.nztri.org/sites/default/files/Significance\\_of\\_Southern\\_Lakes\\_Ski\\_Areas\\_Report\\_Dec05.pdf](http://www.nztri.org/sites/default/files/Significance_of_Southern_Lakes_Ski_Areas_Report_Dec05.pdf) (accessed 31 July 2014).
- Orams, M. 1999: *Marine tourism: development, impacts and management*. Routledge, New York, USA. 115 p.
- Overton, J.; Price, R.; Ferrier, S.; Manion, G. n.d.: GDM Terrestrial Ecosystem Classification. Landcare Research, New Zealand. 24 p. [www.landcareresearch.co.nz/\\_\\_data/assets/pdf\\_file/0006/21795/ExplanationofGDMTerrestrialEcosystemClassifications.pdf](http://www.landcareresearch.co.nz/__data/assets/pdf_file/0006/21795/ExplanationofGDMTerrestrialEcosystemClassifications.pdf) (accessed 31 March 2015).
- Overton, J.M.; Price, R.; Stephens, T.; Cook, S.; Earl, R.; Wright, E.; Walker, S. 2010: Conservation planning and reporting using the Vital Sites Model. Landcare Research and Department of Conservation, Lincoln, New Zealand. 108 p.
- Owen, K.L.; Wilson, T.D.; Latham, P.M.; Young, K.D. 2006: Distribution and conservation of shorebirds in the Bay of Plenty, New Zealand, 1984–2003. *Technical Report Series No. 26*. Department of Conservation, Rotorua, New Zealand. 109 p.
- Oyston, E.; Brown, G. 2011: Identifying conservation values, park experiences, and development preferences in the Otago region of New Zealand: a summary of a public participation geographic information system study in the Southland region. Department of Conservation, New Zealand. 15 p. [www.doc.govt.nz/Documents/about-doc/role/policies-and-plans/cms/southland-values-survey-results.pdf](http://www.doc.govt.nz/Documents/about-doc/role/policies-and-plans/cms/southland-values-survey-results.pdf) (accessed 27 May 2013).
- Pacey, H.A. 2005: The benefits and barriers to GIS for Māori. Unpublished Master of Indigenous Planning and Development thesis, Lincoln University, Lincoln, New Zealand. 182 p. [http://researcharchive.lincoln.ac.nz/bitstream/10182/655/3/Pacey\\_mipd.pdf](http://researcharchive.lincoln.ac.nz/bitstream/10182/655/3/Pacey_mipd.pdf) (accessed 31 July 2014).
- Parfitt, R.L.; Lilburne, L.R.; Shepherd, T.G.; Andrew, R.M. 2002: Vulnerable soils: national maps and models of resistance to pressures. Proceedings of Soil Quality and Sustainable Land Management Conference, 3–5 April 2002, Palmerston North, New Zealand.

- Parshotam, A.; Elliott, S.; Shankar, U.; Wadhwa, S. 2013: National nutrient mapping using the CLUES model. *NIWA Client Report HAM2013-086* prepared for the Parliamentary Commissioner for the Environment, New Zealand. 67 p. [www.pce.parliament.nz/assets/Uploads/National-nutrient-mapping-using-the-CLUES-model.pdf](http://www.pce.parliament.nz/assets/Uploads/National-nutrient-mapping-using-the-CLUES-model.pdf) (accessed 29 May 2014).
- Patterson, M.; Cole, A. 1999: Assessing the value of New Zealand's biodiversity. School of Resource and Environmental Planning, Massey University, Palmerston North, New Zealand.
- Patterson, M.G.; Cole, A.O. 2013: 'Total economic value' of New Zealand's land-based ecosystems and their services. Pp. 496–510 in Dymond, J.R. (Ed.): *Ecosystem services in New Zealand—conditions and trends*. Manaaki Whenua Press, Lincoln, New Zealand.
- Petter, M.; Mooney, S.; Maynard, S.M.; Davidson, A.; Cox, M.; Horosak, I. 2012: A methodology to map ecosystem functions to support ecosystem services assessments. *Ecology and Society* 18(1): 31.
- Phillips, C.J.; Marden, M. 2010: Growth performance of selected New Zealand indigenous conifer and broadleaved trees. *Conservation Quorum* 61: 9–11. [www.gdc.govt.nz/assets/Files/CQuorum/CQ-Spring-2010.pdf](http://www.gdc.govt.nz/assets/Files/CQuorum/CQ-Spring-2010.pdf) (accessed 19 June 2013).
- Phillips, C.J.; Marden, M. 2012: Future forest species for erosion control—something different? *Conservation Quorum* 67: 12–13. [www.gdc.govt.nz/assets/Files/CQuorum/CQ-Autumn-2012.pdf](http://www.gdc.govt.nz/assets/Files/CQuorum/CQ-Autumn-2012.pdf) (accessed 19 June 2013).
- Plieninger, T.; Dijks, S.; Oteros, R.; Bieling, C. 2013: Assessing, mapping, and quantifying cultural ecosystem services at community level. *Land Use Policy* 33: 118–129.
- Potts, T.; Burdon, D.; Jackson, J.; Atkins, J.; Hastings, E.; Langmead, O. 2014: Do marine protected areas deliver flows of ecosystem services to support human welfare? *Marine Policy* 44: 139–148.
- Premium Research 2011: Department of Conservation national survey: report 1: quintessentially kiwi. Prepared for the Department of Conservation, New Zealand. 11 p. [www.doc.govt.nz/Documents/about-doc/role/visitor-research/quintessentially-kiwi.pdf](http://www.doc.govt.nz/Documents/about-doc/role/visitor-research/quintessentially-kiwi.pdf) (accessed 31 July 2014).
- Quinn, J.M.; Cooper, A.B.; Davies-Colley, R.J.; Rutherford, J.C.; Williamson, R.B. 1997: Land use effects on habitat, water quality, periphyton, and benthic invertebrates in Waikato, New Zealand, hill-country streams. *New Zealand Journal of Marine and Freshwater Research* 31(5): 579–597.
- Quinn, J.M.; Stroud, M.J. 2002: Water quality and sediment and nutrient export from New Zealand hill-land catchments of contrasting land use. *New Zealand Journal of Marine and Freshwater Research* 36(2): 409–429.
- Rader, R.; Edwards, W.; Westcott, D.A.; Cunningham, S.A.; Howlett, B.G. 2011: Pollen transport differs among bees and flies in a human-modified landscape. *Diversity and Distributions* 17: 519–529.
- Rader, R.; Edwards, E.; Westcott, D.A.; Cunningham, S.A.; Howlett, B.G. 2013: Diurnal effectiveness of pollination by bees and flies in agricultural *Brassica rapa*: implications for ecosystem resilience. *Basic and Applied Ecology* 14: 20–27.
- Rader, R.; Howlett, B.G.; Cunningham, S.A.; Westcott, D.A.; Edwards, W. 2012: Spatial and temporal variation in pollinator effectiveness: do unmanaged insects provide consistent pollination services to mass flowering crops? *Journal of Applied Ecology* 49(1): 126–134.
- Rader, R.; Howlett, B.G.; Cunningham, S.A.; Westcott, D.A.; Newstrom-Lloyd, L.E.; Walker, M.K.; Teulon, D.A.J.; Edwards, W. 2009: Alternative pollinator taxa are equally efficient but not as effective as the honeybee in a mass flowering crop. *Journal of Applied Ecology* 2009(46): 1080–1087.
- Ratima, M. 2010: Māori health promotion—a comprehensive definition and strategic considerations. Tuamata Associates report prepared for the Health Promotion Forum of New Zealand / Runanga Whakapiki Ake i te Hauora o Aotearoa. 31 p.
- Raymond, C.M.; Brown, G. 2011: Assessing spatial association between perceptions of landscape value and climate risk for use in climate planning. *Climate Change* 104: 653–678.
- Raymond, C.M.; Bryan, B.A.; MacDonald, D.H.; Cast, A.; Strathearn, S.; Grandgirard, A.; Kalivas, T. 2009: Mapping community values for natural capital and ecosystem services. *Ecological Economics* 68: 1301–1315.
- Roberts, L.; Brower, A.; Kerr, G.; Lambert, S.; McWilliam, W.; Moore, K.; Quinn, J.; Simmons, D.; Thrush, S.; Townsend, M.; Blaschke, P.; Costanza, R.; Cullen, R.; Hughey, K.; Wratten, S. 2015: The nature of wellbeing: how nature's ecosystem services contribute to the wellbeing of New Zealand and New Zealanders. Department of Conservation, Wellington, New Zealand. 145 p. [www.doc.govt.nz/Documents/science-and-technical/sap258entire.pdf](http://www.doc.govt.nz/Documents/science-and-technical/sap258entire.pdf) (accessed 8 May 2015).
- Robertson, C.J.R.; Hyvönen, P.; Fraser, M.J.; Pickard, C.R. 2007: Atlas of bird distribution in New Zealand 1999–2004. The Ornithological Society of New Zealand Inc., Wellington, New Zealand. 533 p.

- Rogers, A.D. 2012: An ecosystem approach to management of seamounts in the Southern Indian Ocean. Volume 1—overview of seamount ecosystems and biodiversity. IUCN, Gland, Switzerland. 18+ii p. <https://portals.iucn.org/library/efiles/documents/2012-078-1.pdf> (accessed 31 July 2014).
- Samarasinghe, O.; Briggs, C.; Greenhalgh, S. 2009: Mapping the values of New Zealand's coastal waters. 5. A meta-analysis of economic values. *MAF Biosecurity New Zealand Technical Paper No: 2010/09*. Ministry of Agriculture and Forestry, Wellington, New Zealand. 76 p. [www.biosecurity.govt.nz/files/pests/salt-freshwater/economic-values-mapping-analysis.pdf](http://www.biosecurity.govt.nz/files/pests/salt-freshwater/economic-values-mapping-analysis.pdf) (accessed 28 July 2014).
- Satterfield, T.; Gregory, R.; Klain, S.; Roberts, M.; Chan, K.M. 2013: Culture, intangibles and metrics in environmental management. *Journal of Environmental Management* 117: 103–114.
- Savage, C.; Thrush, S.F.; Lohrer, A.M.; Hewitt, J.E. 2012: Ecosystem services transcend boundaries: estuaries provide resource subsidies and influence functional diversity in coastal benthic communities. *PLoS ONE* 7(8):e42708. doi:10.1371/journal.pone.0042708
- Schägnler, J.P.; Brander, L.; Maes, J.; Hartje, V. 2012: Mapping ecosystem services' values: current practice and future prospects. Fondazione Eni Enrico Mattei Working Paper Series. Fondazione Eni Enrico Mattei, Milano, Italy. 42 p. [http://papers.ssrn.com/sol3/papers.cfm?abstract\\_id=2160714###](http://papers.ssrn.com/sol3/papers.cfm?abstract_id=2160714###) (accessed 31 July 2014).
- Schaich, H.; Bieling, C.; Pleninger, T. 2010: Linking ecosystem services with cultural landscape research. *GAIA* 19(4): 269–277.
- Schweder-Goad, C.M. 2008: Geographic referencing of the New Zealand Whale Strandings Database. Stranding records January 1846–March 2007. Department of Conservation, New Zealand (unpublished). 22 p. (DOCDM-319174)
- Semadeni-Davies, A.; Elliot, S.; Shankar, U. 2014: How CLUES can help in managing catchment nutrient limits. In: Currie, L.D.; Christensen, C.L. (Eds). Nutrient management for the farm, catchment and community. *Occasional Report No. 27*. Fertilizer and Lime Research Centre, Massey University, Palmerston North, New Zealand. [www.massey.ac.nz/~flrc/workshops/14/Manuscripts/Paper\\_Semadeni-Davies\\_2014.pdf](http://www.massey.ac.nz/~flrc/workshops/14/Manuscripts/Paper_Semadeni-Davies_2014.pdf) (accessed 1 May 2015).
- Shepherd, T.G.; Lilburne, L.R.; Sparling, G.P. 2000: A rule-based assessment of soil structural vulnerability. *Soil News* 48(5): 127–132.
- Sherrouse, B.C.; Clement, J.M.; Semmens, D.J. 2011: A GIS application for assessing mapping, and quantifying the social values of ecosystem services. *Applied Geography* 32(2): 748–760.
- Sherrouse, B.C.; Semmens, D.J. 2012: Social values for ecosystem services, version 2.0 (SolVES 2.0): documentation and user manual. *U.S. Geological Survey Open-File Report 2012-1023*. US Geological Survey, Reston, Virginia, USA. 55 p. <http://pubs.usgs.gov/of/2012/1023/contents/OF12-1023.pdf> (accessed 31 July 2014).
- Simard, F.; Spadone, A. (Eds) 2012: An ecosystem approach to management of seamounts in the Southern Indian Ocean. Volume 2—anthropogenic threats to seamount ecosystems and biodiversity. IUCN, Gland, Switzerland. iv+64 p. <https://portals.iucn.org/library/efiles/documents/2012-078-2.pdf> (accessed 31 July 2014).
- Singers, N.J.D.; Rogers, G.M. 2014: A classification of New Zealand's terrestrial ecosystems. *Science for Conservation* 325. Department of Conservation, Wellington, New Zealand. 87 p.
- SLUA (Soil and Land Use Alliance) 2012: Reporting on soils at the national level. Prepared for the Parliamentary Commissioner for the Environment, New Zealand. 56 p.
- Smith, A.N.H. 2006: Evaluation of the New Zealand Marine Environment Classification for shallow coastal rocky reef fish communities. Unpublished MSc thesis, University of Auckland, Auckland, New Zealand. 133 p.
- Smith, A.N.H. 2008: Modelling distributions of 72 species of fish on rocky reefs using Boosted Regression Trees. Joint conference of the New Zealand Marine Sciences Society (NZMSS) and the Australian Marine Science Association, Canterbury University, Christchurch, New Zealand.
- Smith, A.N.H.; Duffy, C.A.J.; Leathwick, J.R. 2013: Predicting the distribution and relative abundance of fishes on shallow subtidal reefs around New Zealand. *Science for Conservation* 323. Department of Conservation, Wellington, New Zealand. 25 p.
- Snelder, T.; Biggs, B.; Weatherhead, M. 2004: New Zealand River Environment Classification user guide. Prepared by the National Institute of Water and Atmospheric Research Ltd (NIWA) for the Ministry for the Environment, Wellington, New Zealand. 114 p. [www.mfe.govt.nz/environmental-reporting/about-environmental-reporting/classification-systems/rec-user-guide-2010.pdf](http://www.mfe.govt.nz/environmental-reporting/about-environmental-reporting/classification-systems/rec-user-guide-2010.pdf) (accessed 31 July 2014).
- Snelder, T.; Leathwick, J.; Dey, K.; Weatherhead, M.; Fenwick, G.; Francis, M.; Gorman, R.; Grieve, J.; Hadfield, M.; Hewitt, J.; Hume, T.; Richardson, K.; Rowdon, A.; Uddstrom, M.; Wild, M.; Zeldis, J. 2005: The New Zealand Marine Environment Classification. Ministry for the Environment, Wellington, New Zealand. 70 p.

- Snelder, T.H.; Biggs, B.J.F. 2002: Multiscale river environment classification for water resources management. *Journal of the American Water Resources Association* 38(5): 1225-1239.
- Sorrell, B.; Unwin, M.; Dey, K.; Hurren, H. 2006: Snapshot—lake water quality. NIWA Client Report CHC2006-145. Prepared for the Ministry for the Environment by the National Institute of Water and Atmospheric Research Ltd (NIWA), Christchurch, New Zealand. 68 p. <http://ecan.govt.nz/publications/Reports/nz-lakes-water-quality-snapshot.pdf> (accessed 28 November 2014).
- Spasić, K. 2011: Cultural background and meaning of Ta Moko—Māori tattoos. Unpublished Bachelor thesis, Masaryk University, Czech Republic. 45 p.
- Standards New Zealand 2004: Tracks and outdoor visitor structures. SNZ HB 8630:2004. Standards New Zealand, Wellington, New Zealand. 80 p. (OldDM-724391)
- Stephenson, J.; Bauchop, H.; Petchey, P. 2004: Bannockburn heritage landscape study. *Science for Conservation* 244. Department of Conservation, Wellington, New Zealand. 120 p.
- Stevenson, M.A.; Benard, H.; Bolger, P.; Morris, R.S. 2005: Spatial epidemiology of the Asian honey bee mite (*Varroa destructor*) in the North Island of New Zealand. *Preventative Veterinary Medicine* 71: 241-252.
- Steve Thompson & Partners n.d.: New Zealand Land Cover Database 2 user guide. Ministry for the Environment, New Zealand. 24 p.
- Steward, G.A. 2011: Growth and yield of New Zealand kauri (*Agathis australis* (D. Don) Lindl.). Unpublished Master of Forestry Science thesis, University of Canterbury, Christchurch, New Zealand. 150 p.
- Strain, L.; Rajabifard, A.; Williamson, I. 2006: Marine administration and spatial data infrastructure. *Marine Policy* 30(4): 431-441.
- Swetnam, R.D.; Fisher, B.; Mbilinyi, B.P.; Munishi, P.K.T.; Willcock, S.; Ricketts, T.; Mwakalila, S.; Balmford, A.; Burgess, N.D.; Marshall, A.R.; Lewis, S.L. 2011: Mapping socio-economic scenarios of land cover change: a GIS method to enable ecosystem service modelling. *Journal of Environmental Management* 92: 563-574.
- Tait, P.; Baskaran, R.; Cullen, R.; Bicknell, K. 2012: Non-market valuation of water quality: addressing spatially heterogeneous preferences using GIS and a random parameter logit model. *Ecological Economics* 75: 15-21.
- Taranto, G.H.; Kvile, K.Ø.; Pitcher, T.J.; Morato, T. 2012: An ecosystem evaluation framework for global seamount conservation and management. *PLoS ONE* 7(8): e42950. doi:10.1371/journal.pone.0042950
- Taylor, G.A. 2000: Action plan for seabird conservation in New Zealand. Part A: Threatened seabirds. *Threatened Species Occasional Publication No. 16*. Department of Conservation, Wellington, New Zealand. 234 p.
- Taylor, M.J. 2002: The National Inanga Spawning Database: trends and implications for spawning site management. *Science for Conservation* 188. Department of Conservation, Wellington, New Zealand. 37 p.
- Tengberg, A.; Fredholm, S.; Eliasson, I.; Knez, I.; Saltzman, K.; Wetterberg, O. 2012: Cultural ecosystem services provided by landscapes: assessment of heritage values and identity. *Ecosystem Services* 2: 14-26.
- Te Whāiti, Z.; Puketapu-Andrews, G. 1997: Kōrero Āwhina: Councillor. Pp. 60-74 in Te Whāiti, P.; McCarthy, M.; Durie, A. (Eds): *Mai i Rangiatea: Māori wellbeing and development*. Auckland University Press and Bridget Williams Books, Auckland, New Zealand.
- Thompson, F.N.; Berkenbusch, K.; Abraham, E.R. 2013: Marine mammal bycatch in New Zealand trawl fisheries, 1995-96 to 2010-11. *New Zealand Aquatic Environment and Biodiversity Report No. 105*. Ministry for Primary Industries, Wellington, New Zealand. 72 p.
- Thrush, S.F.; Hewitt, J.E.; Cummings, V.J.; Ellis, J.I.; Hatton, C.; Lohrer, A.; Norkko, A. 2004: Muddy waters: elevating sediment input to coastal and estuarine habitats. *Frontiers in Ecology and the Environment* 2: 299-306.
- Tipa, G. 2010: Tangata Whenua. Consideration of a significance assessment for Tangata Whenua river values. Pp. 1-33 in Hughey, K.F.D.; Baker, M.A. (Eds): *The River Values Assessment System: Volume 2: Application to cultural, production and environmental values*. *LEaP Report No. 24B*. Lincoln University, Lincoln, New Zealand. [www.envirolink.govt.nz/PageFiles/31/Leap%2024B-The-River-Values-Assessment-System-Vol-2.pdf](http://www.envirolink.govt.nz/PageFiles/31/Leap%2024B-The-River-Values-Assessment-System-Vol-2.pdf) (accessed 31 July 2014).
- Tipa, G.; Teirney, L. 2006: A cultural health index for streams and waterways: a tool for nationwide use. Ministry for the Environment, Wellington, New Zealand. 54 p. [www.mfe.govt.nz/publications/water/cultural-health-index-for-streams-and-waterways-tech-report-apr06/cultural-health-index-for-streams-and-waterways-tech-report-apr06.pdf](http://www.mfe.govt.nz/publications/water/cultural-health-index-for-streams-and-waterways-tech-report-apr06/cultural-health-index-for-streams-and-waterways-tech-report-apr06.pdf) (accessed 31 July 2014).



- Tisdell, C. 2007: The economic importance of wildlife conservation on the Otago Peninsula—20 years on. *Working Papers on Economics, Ecology and the Environment No. 144*. The School of Economics, University of Queensland, Brisbane, Queensland, Australia. 21 p.
- Tompkins, J-M. 2010: Ecosystem services provided by native New Zealand plants in vineyards. Unpublished PhD thesis, Lincoln University, Lincoln, New Zealand. 282 p.
- Townsend, M.; Clark, D.; Lohrer, D.; Ellis, J.; Lundquist, C.; Hewitt, J.; Thrush, S. 2014a: An ecosystem services matrix for New Zealand's coastal marine environment. October 2014. *NIWA Client Report HAM2014-074* prepared for the Department of Conservation by the National Institute of Water and Atmospheric Research (NIWA), Wellington, New Zealand (unpublished). 56 p. (DOCDM-1502340)
- Townsend, M.; Thrush, S. 2010: Ecosystem functioning, goods and services in the coastal environment. *Auckland Regional Council Technical Report 2010/033*. Prepared by the National Institute of Water and Atmospheric Research (NIWA). Auckland Regional Council, Auckland, New Zealand. 53 p. [www.aucklandcouncil.govt.nz/SiteCollectionDocuments/aboutcouncil/planspoliciespublications/technicalpublications/tr2010033ecosystemfunctioninggoodsandservicesinthecoastalenvironment.pdf](http://www.aucklandcouncil.govt.nz/SiteCollectionDocuments/aboutcouncil/planspoliciespublications/technicalpublications/tr2010033ecosystemfunctioninggoodsandservicesinthecoastalenvironment.pdf) (accessed 31 July 2014).
- Townsend, M.; Thrush, S.F.; Lohrer, A.M.; Hewitt, J.E.; Lundquist, C.J.; Carbines, M.; Felsing, M. 2014b: Overcoming the challenges of data scarcity in mapping marine ecosystem services potential. *Ecosystem Services* 8: 44-55.
- Townsend, M.; Thrush, S.F.; Wadhwa, S.; Lohrer, D.; Lundquist, C.; Hewitt, J.E. 2012: Mapping ecosystem services in the Hauraki Gulf. Prepared for Auckland Council, New Zealand. 66 p.
- Townsend, T.; Thrush, S.F.; Carbines, M.J. 2011: Simplifying the complex: an 'Ecosystem Principles Approach' to goods and services management in marine coastal ecosystems. *Marine Ecology Progress Series* 434: 291-301.
- Troy, A.; Wilson, M.A. 2006: Mapping ecosystem services: practical challenges and opportunities in linking GIS and value transfer. *Ecological Economics* 60: 435-449.
- Tylianakis, J.M. 2013: The global plight of pollinators. *Science* 339: 1532-1533.
- Tyrväinen, L.; Mäkinen, K.; Schipperijn, J. 2007: Tools for mapping social values of urban woodlands and other green areas. *Landscape and Urban Planning* 79: 5-19.
- Unwin, M. 2014: National scale mapping of rivers showing a threshold Dissolved Inorganic Nitrogen concentration of 0.8 mg/L. Prepared for Irrigation New Zealand by the National Institute of Water and Atmospheric Research (NIWA), Christchurch, New Zealand. 10 p. [www.interest.co.nz/sites/default/files/DIN%20NIWA.pdf](http://www.interest.co.nz/sites/default/files/DIN%20NIWA.pdf) (accessed 29 May 2014).
- Unwin, M.; Snelder, T.; Booker, D.; Ballantine, D.; Lessard, J. 2010: Modelling water quality in New Zealand rivers from catchment-scale physical, hydrological and land cover descriptors using random forest models. *NIWA Client Report CHC2010-037* prepared for the Ministry for the Environment by the National Institute of Water and Atmospheric Research (NIWA), Wellington, New Zealand. 52 p.
- Unwin, M.J.; Larned, S. 2013: Statistical models, indicators and trend analyses for reporting national-scale river water quality (NEMAR Phase 3). *NIWA Client Report CHC2013-033* prepared for the Ministry for the Environment by the National Institute of Water and Atmospheric Research (NIWA), Wellington, New Zealand. 71 p. [www.mfe.govt.nz/publications/ser/statistical-models-indicators-trend-analysis-reporting-national-scale-river-water-quality.pdf](http://www.mfe.govt.nz/publications/ser/statistical-models-indicators-trend-analysis-reporting-national-scale-river-water-quality.pdf) (accessed 29 May 2014).
- Vačkář, D.; Chobot, K.; Orlitová, E. 2012: Spatial relationships between human population density, land use intensity and biodiversity in the Czech Republic. *Landscape Ecology* 27(9): 1279-1290.
- van den Belt, M.; Cole, A. 2014: Ecosystem goods and services in marine protected areas (MPAs). *Science for Conservation* 326. Department of Conservation, Wellington, New Zealand. 96 p.
- van Herzele, A.; Wiedemann, T. 2003: A monitoring tool for the provision of accessible and attractive urban green spaces. *Landscape and Urban Planning* 63: 109-126.
- van Riper, C.J.; Kyle, G.T.; Sutton, S.G.; Barnes, M.; Sherrouse, B.C. 2012: Mapping outdoor recreationists' perceived social values for ecosystem services at Hinchinbrook Island National Park, Australia. *Applied Geography* 35: 164-173.
- Vigerstol, K.L.; Aukema, J.E. 2011: A comparison of tools for modelling freshwater ecosystem services. *Journal of Environmental Management* 92: 2403-2409.
- Villa, F.; Bagstad, K.; Johnson, G.; Voigt, B. 2011: Scientific instruments for climate change adaptation: estimating and optimizing the efficiency of ecosystem service provision. *Economía Agraria y Recursos Naturales* 11(1): 105-128.
- Visitor Solutions Ltd; The New Zealand Tourism Research Institute (AUT University); Geographic Business Solutions Ltd 2012: Developing a geodatabase for mapping recreational use and value indicator data of New Zealand's coastal/marine environment. Prepared for the Department of Conservation, New Zealand. 107 p.

- Vizzari, M. 2011: Spatial modelling of potential landscape quality. *Applied Geography* 31: 108–118.
- Wade, T.; Sommer, S. (Eds) 2006: A to Z GIS: An illustrated dictionary of geographic information systems. ESRI Press, Redlands, California, USA. 288 p.
- Waddel, S.R. 1998: Restoring Kaitiakitanga: evaluating the recognition of indigenous rights in assessment of environmental effects. Unpublished MSc thesis, Lincoln University, Lincoln, New Zealand. 99 p.
- Walls, K. 2006: Nearshore marine classification and inventory—a planning tool to help identify marine protected areas for the nearshore of New Zealand. Department of Conservation, Wellington, New Zealand. 342 p.
- Watson, K. 2010: A survey of some archaeological sites in the St James Conservation Area. Department of Conservation, New Zealand (unpublished). 55 p. (DOCDM-683462)
- Whitehead, A.L.; Kujala, H.; Ives, C.D.; Gordon, A.; Lentini, P.E.; Wintle, B.A.; Nicholson, E.; Raymond, C.M. 2014: Integrating biological and social values when prioritising places for biodiversity conservation. *Conservation Biology* 28(4): 992–1003.
- Williams, P.A.; Wiser, S.; Clarkson, B.; Stanley, M. 2007: Review: New Zealand’s historically rare terrestrial ecosystems set in a physical and physiognomic framework. *New Zealand Journal of Ecology* 31(2): 119–128.
- Wilson, M.A.; Troy, A.; Costanza, R. 2004: The economic geography of ecosystem goods and services: revealing the monetary value of landscapes through transfer methods and Geographic Information Systems. Pp. 66–94 in Dietrich, M.; van der Straaten, J. (Eds): Cultural landscapes and land use. The nature conservation–society interface. Springer, Netherlands.
- Winkworth, C.L.; Mattaei, C.D.; Townsend, C. 2010: Using native riparian barriers to reduce *Giardia* in agricultural runoff to freshwater ecosystems. *Journal of Water and Health* 8(4): 631–645.
- Wood, A.C.L.; Rowden, A.A.; Compton, T.J.; Gordon, D.P.; Probert, P.K. 2013: Habitat-forming bryozoans in New Zealand: their known and predicted distribution in relation to broad-scale environmental variables and fishing effort. *PLoS ONE* 8(9): e75160. doi:10.1371/journal.pone.0075160
- Wouters, M. 2011: Socio-economic effects of concession-based tourism in New Zealand’s national parks. *Science for Conservation Series* 309. Department of Conservation, Wellington, New Zealand. 90 p.
- Wratten, S.; Meurk, C.; Sam, S.; Prendergast, T.A. 2006: Greening Waipara, Issue 1, September 2006. Lincoln University, Lincoln, New Zealand. 7 p. [http://bioprotection.org.nz/sites/default/files/greening\\_waipara\\_newsletter\\_no\\_1.pdf](http://bioprotection.org.nz/sites/default/files/greening_waipara_newsletter_no_1.pdf) (accessed 14 September 2014).
- Wratten, S.; Meurk, C.; Sam, S.; Tompkins, J. 2007: Greening Waipara, Issue 4, December 2007. 7 p. Lincoln University, Lincoln, New Zealand. [http://bioprotection.org.nz/sites/default/files/greening\\_waipara\\_newsletter\\_no\\_4.pdf](http://bioprotection.org.nz/sites/default/files/greening_waipara_newsletter_no_4.pdf) (accessed 14 September 2014).
- Wynne-Jones, J.; Gray, A.; Hill, L.; Heinemann, A. 2014: National panel survey of marine recreational fishers 2011–12: harvest estimates. New Zealand Fisheries Assessment Report 2014/67. Ministry for Primary Industries, Wellington, New Zealand. 139 p. [http://fs.fish.govt.nz/Doc/23718/FAR\\_2014\\_67\\_2847\\_MAF2010-01.pdf.ashx](http://fs.fish.govt.nz/Doc/23718/FAR_2014_67_2847_MAF2010-01.pdf.ashx) (accessed 15 April 2015).

## Appendix 1

### GIS-based tools for assessing ecosystem services

The information presented in Table A1.1 in this appendix is based on a variety of sources, including the Ecosystem-Based Management (EBM) Tools Database ([www.ebmtools.org/about\\_ebm\\_tools.html](http://www.ebmtools.org/about_ebm_tools.html)), a presentation by Bethanna Jackson (Victoria University of Wellington) and the other websites/literature cited under ‘Key literature/references’.

Table A1.1. GIS-based tools for assessing ecosystem services.

TOOL-SET	DESCRIPTION	SCALE	DATA RESOLUTION REQUIREMENT	CASE STUDY SITES	TEMPORAL SCALE	SCENARIOS?	COST	GENERAL DATA REQUIREMENTS	CURRENT ECOSYSTEM SERVICE CAPABILITY	KEY LITERATURE/REFERENCES
Artificial Intelligence for Ecosystem Services (ARIES)	ARIES is a web-based open-source ecosystem service assessment software that is based on explicit quantification of spatial flows of benefits from nature to humans. The development of ARIES began in 2007. It is the first systematic tool to address delivery efficiency problems in ecosystem service models. It allows users to compute potential provision and the proportion of the service utilised or not utilised. ARIES also tailors each model to physical, socioeconomic and ecological characteristics of the study area on the basis of knowledge stored in its ontologies (i.e. computer readable statements of knowledge), using a reasoning algorithm that bases its inference on available data. It first uses artificial intelligence techniques to examine GIS data patterns and extract model knowledge from a stored knowledge base to best represent the situation at hand. It then identifies and independently models individual benefits of ecosystem services, and then links each computed benefit to others. Ad-hoc probabilistic Bayesian network models are then built to map ecological and socioeconomic factors contributing to the provision, use and depletion of ecosystem services. Spatial flow models are used to identify the strengths of ecosystem flows providing benefits from ecosystems to people. Three fundamental maps are produced within an ARIES session, namely source maps (where the carrier of the ecosystem service is generated), sink maps (where service carriers can be depleted) and use maps (where users need the service). Openly distributable global datasets and models are included in ARIES, but local datasets may be required to improve accuracy and/or resolution of the models. Results can be imported into external GIS viewing platforms for further display and analysis.	Local to global	All data provided	USA, Madagascar, Mexico, Spain, Tanzania, Dominican Republic &	Most services support monthly to annual	Yes	Free	Global datasets provided. Local datasets may be necessary to improve accuracy and/or resolution.	Carbon sequestration and storage, aesthetic viewsheds, open space proximity, flood regulation, subsistence fisheries, coastal flood regulation, water supply, recreation, and sediment regulation.	http://ariesonline.org See Bagstad et al. (2011); Villa et al. (2011). Contact Ken Bagstad (kbagstad@gmail.com) or info@ariesonline.org
Co\$ting Nature	Co\$ting Nature (CN) is a fully documented, web-based tool for mapping ecosystem services now and in the future. CN provides maps of ecosystem services produced (potential) and consumed (realised) by local and downstream beneficiaries. It has a scenario generator for assessing the impacts of land use and cover change scenarios on these ecosystem services and on biodiversity. CN is a Policy Support System (PSS) that provides detailed spatial datasets at a resolution of 1 km (for national-scale analyses) and 1 ha (for local-scale analyses), globally. It calculates a baseline for current ecosystem service provision and can be used to test the impact of intervention scenarios. A baseline analysis and comparison with land use change scenario can be completed for any site globally within an hour since all required data are provided. CN combines ecosystem services with other factors including biodiversity, endemism, current pressure and future threat to determine a comprehensive conservation prioritisation.	Local to global	All data provided, globally	Madagascar, South America, Borneo, Zambia & Nepal	Annual	Yes	Free	All data provided (uses mean climate 1950-2010 and land cover 2010).	Water quantity and quality, hazard mitigation, carbon storage and sequestration, and nature-based tourism.	www.policysupport.org/costingnature See Mulligan et al. (2010). Contact Mark Mulligan, King's College London (mark.mulligan@kcl.ac.uk)

Continued on next page

Table A1.1 continued

TOOL-SET	DESCRIPTION	SCALE	DATA RESOLUTION REQUIREMENT	CASE STUDY SITES	TEMPORAL SCALE	SCENARIOS?	COST	GENERAL DATA REQUIREMENTS	CURRENT ECOSYSTEM SERVICE CAPABILITY	KEY LITERATURE/REFERENCES
ENVISION	ENVISION is a GIS-based tool that combines a spatially explicit polygon-based representation of a landscape, a set of decision rules linked to alternative scenarios, landscape change models and service models (including ecological, social and economic) to simulate land use change to provide support for land use planning and environmental assessments.	Local to global	Polygon-based (optimal polygon size varies depending on application)	USA & Canada	Varies depending on application	Yes	Free	Land use/land cover data plus other data, depending on application.	Flexible in its application. Examples include water supply/demand and hazard assessments under changing climates, fire/growth/restoration dynamics in fire-prone landscapes, and ecosystem service assessments.	<a href="http://envision.bioe.orst.edu">http://envision.bioe.orst.edu</a> Contact John Bolte, Oregon State University (john.bolte@oregonstate.edu)
The Global Unified Metamodel of the Biosphere (GUMBO)	GUMBO is a global model used to assess the dynamics and values of ecosystem services. It represents a synthesis and simplification of several existing dynamic global models, and explores the global dynamics and interactions of the sociology, economy and ecology of the Earth. It is used to generate and analyse global change scenarios with economic and cultural dimensions. GUMBO consists of five sectors (atmosphere, lithosphere, hydrosphere, biosphere and anthroposphere/human systems) and 11 biomes (open ocean, coastal ocean, forests, grasslands, wetlands, lakes/rivers, deserts, tundra, ice/rock, croplands and urban). The model is calibrated using historical data on land use, atmospheric carbon dioxide concentrations, global mean temperature, economic production, population and other variables. Different valuation methods are implemented in the model allowing users to compare results. GUMBO can be run under readily available software on an average PC.	Global	All data provided	Global	Annual (1900-2100)	Yes	Free	Uses existing observational databases.	Ecosystem services are grouped into ten major types: gas regulation, climate regulation, disturbance regulation, water use, soil formation, nutrient cycling, waste treatment, food production, raw materials and recreation/cultural.	<a href="http://ecoinformatics.uvm.edu/projects/the-gumbo-model.html">http://ecoinformatics.uvm.edu/projects/the-gumbo-model.html</a> See Boumans et al. (2002). Contact Roelof Boumans, Accounting for Affordable Futures and Gund Institute for Ecological Economics (rboumans@afordablefutures.com)
Integrated Valuation of Ecosystem Services and Tradeoffs (InVEST)	InVEST is a suite of ecosystem service models based on production functions that define how an ecosystem's structure and function affect the flows and values of ecosystem services. InVEST is spatially explicit, and enables the production of maps indicating where ecosystem services are provided and where they are consumed. This can be done for single or multiple ecosystem services. Both biophysical results and economic values are produced as results. It is also used to compare alternative management scenarios to explore their effect on the provisioning of ecosystem services. Mapping software (e.g. ArcGIS or QGIS) is required to view results from the models. Basic to intermediate skills in ArcGIS are required, but there is no need to have a knowledge of Python programming.	Local to global	Varied	USA, South America, Canada, China, Indonesia & Tanzania	Daily to annual	Yes	Free	Initial versions of InVEST offer simple models with few input requirements. For more details, see <a href="http://ncp-dev.stanford.edu/~dataportal/invest-releases/documentation/current_release/data_requirements.html">http://ncp-dev.stanford.edu/~dataportal/invest-releases/documentation/current_release/data_requirements.html</a> .	Terrestrial and freshwater: habitat quality (terrestrial only), carbon storage and sequestration, reservoir hydropower production, water purification (nutrient retention), erosion control, crop pollination, timber production, non-timber	<a href="http://www.naturalcapitalproject.org/inVEST.html">www.naturalcapitalproject.org/inVEST.html</a> and <a href="http://www.naturalcapitalproject.org/pubs/NatCap_InVEST_and_Case_Study_Summary_TEEB_2010.pdf">www.naturalcapitalproject.org/pubs/NatCap_InVEST_and_Case_Study_Summary_TEEB_2010.pdf</a> Contact Elizabeth Rauer, Stanford University (elizabeth@)

Continued on next page

Table A1.1 continued

TOOL-SET	DESCRIPTION	SCALE	DATA RESOLUTION REQUIREMENT	CASE STUDY SITES	TEMPORAL SCALE	SCENARIOS?	COST	GENERAL DATA REQUIREMENTS	CURRENT ECOSYSTEM SERVICE CAPABILITY	KEY LITERATURE/REFERENCES
Land Utilisation and Capability Indicator GIS (LUCI) Toolbox (LUCI)	LUCI is an integrated, spatially explicit, multi ecosystem services framework that identifies the impact and trade-offs of land management actions from a very fine (sub-field) scale to a regional or national level. It also has the unique and efficient ability to route the flow of water, chemicals and sediment at a high resolution. It is being applied to identify how land management can improve carbon, water flow and quality, and biodiversity while maintaining productivity. LUCI produces single service maps that identify high to low existing value under a particular land management scenario. It also has the capacity to produce multi-service maps used for identifying service trade-offs under a particular land management scenario. LUCI continues to be developed, and will include temporal functionality, economic valuations and improved biodiversity representations in the future.	Sub-field to regional	Optimum resolution 5 m	UK, New Zealand, Greece & Ghana	Sub-daily to annual	Yes		Only land use data, soil data and digital elevation raster data needed for simplest model. Where available, rainfall, river network and land management data should also be used. If changes over time are assessed, more data are needed, such as rainfall, evaporation and chemical inputs. Nationally available data can be updated with local knowledge.	Food provisioning/agricultural productivity, water regulation (including flood risk, erosion and sediment transfer, and water quality), climate regulation (carbon sequestration, storage and emissions), biodiversity and cultural/historical features.	<a href="http://kiwinet.org.nz/viewinfo.aspx?pid=2ef93aa3-c979-4d6e-a205-bd2e00c8a776">http://kiwinet.org.nz/viewinfo.aspx?pid=2ef93aa3-c979-4d6e-a205-bd2e00c8a776</a> Contact Dr Bethanna Jackson, Victoria University of Wellington (bethanna.jackson@vuw.ac.nz)
Multi-scale Integrated Models of Ecosystem Services (MIMES)	The MIMES framework considers multiple ecosystem goods and services simultaneously, and explores their trade-offs and responses to environmental and human drivers. It assesses the magnitude, dynamics and spatial pattern of ecosystem service values at multiple scales. MIMES is programmed in SIMILE software (see <a href="http://www.simulistics.com">www.simulistics.com</a> ).	Marine areas & medium catchments	None	USA, New Zealand (Manawatu Watershed) and at a global scale	Sub-daily to annual	Yes	Free	Spatial, temporal and contextual attributes of ecosystem components (e.g. habitat, species, physical conditions); ecosystem service demand by economic sector; impact of economic activities of ecosystem services.	Assesses multiple ecosystem services, as classified by de Groot et al. (2002).	<a href="http://www.afordablefutures.com/services/mimes">www.afordablefutures.com/services/mimes</a> and <a href="https://code.google.com/p/mimes">https://code.google.com/p/mimes</a> See de Groot et al. (2002); Boumans & Costanza (2007). Contact Roelof Boumans, Accounting for Affordable Futures and Gund Institute for

Continued on next page

Table A1.1 continued

TOOL-SET	DESCRIPTION	SCALE	DATA RESOLUTION REQUIREMENT	CASE STUDY SITES	TEMPORAL SCALE	SCENARIOS?	COST	GENERAL DATA REQUIREMENTS	CURRENT ECOSYSTEM SERVICE CAPABILITY	KEY LITERATURE/REFERENCES
Social Values for Ecosystem Services (SoVES)	SoVES is a GIS-based tool designed to assess, map and quantify perceived social values for ecosystems using a ten-point value index. It is also able to produce statistical models describing the relationship between social value maps and explanatory environmental variables. SoVES requires ArcGIS software.	Local to sub-regional	Varies depending on application	USA & Australia	None	Yes	Free	Social survey data and at least one environmental data layer imported into a geodatabase file format.	Can assess many value types, including aesthetic, biodiversity, cultural, economic, future, historic, intrinsic, learning, life-sustaining, recreation, spiritual and therapeutic. Also allows users to define their own value types.	Ecological Economics (rboumans@afordablefutures.com) <a href="http://solves.cr.usgs.gov">http://solves.cr.usgs.gov</a> See Sherrouse et al. (2011); Sherrouse & Semmens (2012); van Riper et al. (2012). Contact Ben Sherrouse (bcsherrouse@usgs.gov) or Darius Semmens (dsemmens@usgs.gov), United States Geological Survey
New Zealand Forest and Agriculture Regional Model (NZ-Farm)	Landcare Research developed NZ-Farm to help decision-makers assess the economic and environmental impacts of policy on regional land use. This model maximises rural income across a catchment whilst accounting for the environmental impacts of land use and land use changes. Land use types included are pastoral (dairy, sheep, beef, deer), arable (wheat, barley, maize), horticultural (potatoes, grapes, berryfruit), forestry (pine, eucalyptus, native) and other (scrub, DOC-administered land). NZ-Farm has been used in various policy scenarios, such as regional afforestation schemes, proposed caps on nitrogen and phosphorus loads, and implementation of new farm technology and best management practices.	Regional		New Zealand (Manawatu & Hurunui/Wairarapa catchments)		Yes			Greenhouse gas emissions from agriculture and forestry, forest carbon sequestration, water use, and nutrient (phosphorus and nitrogen) and pesticide losses. NZ-Farm is being further developed to include pollination.	<a href="http://www.landcareresearch.co.nz/science/plants-animals-fungi/ecosystems/ecosystem-services/nzfarm">www.landcareresearch.co.nz/science/plants-animals-fungi/ecosystems/ecosystem-services/nzfarm</a>

## References

- Bagstad, K.J.; Villa, F.; Johnson, G.W.; Voigt, B. 2011: Aries—Artificial Intelligence for Ecosystem Services: a guide to models and data, version 1.0. ARIES Report Series N.1. 122 p. <http://ariesonline.org/docs/ARIESModelingGuide1.0.pdf> (accessed 4 June 2013).
- Boumans, R.; Costanza, R. 2007: The Multiscale Integrated Earth Systems Model (MIMES): the dynamics, modelling and valuation of ecosystem services. Pp.104–107 in Van Bers, C.; Petry, D.; Pahl-Wostl, C. (Eds): Global assessments: bridging scales and linking to policy. Report on the joint TIAS-GWSP workshop held at University of Maryland University College, Adelphi, USA, 10–11 May 2007. *GWSP Issues in Global Water System Research*, No. 2. GWSP IPC, Bonn, Germany. <http://doc.utwente.nl/61129/1/Bers07global.pdf> (accessed 28 July 2014).

- Boumans, R.; Costanza, R.; Farley, J.; Wilson, M.A.; Portela, R.; Rotmans, J.; Villa, F.; Grasso, M. 2002. Modelling the dynamics of the integrated earth system and the value of global ecosystem services using the GUMBO model. *Ecological Economics* 41(3): 559–560.
- de Groot, R.S.; Wilson, M.A.; Boumans, R.M.J. 2002: A typology for the classification, description and valuation of ecosystem functions, goods and services. *Ecological Economics* 41: 393–408.
- Mulligan, M.; Guerry, A.; Arkema, K.; Bagstad, K.; Villa, F.; Silvestri, S. 2010: Capturing and quantifying the flow of ecosystem services. Pp. 26–33 in Silvestri, S.; Kershaw, F. (Eds): Framing the flow: innovative approaches to understand, protect and value ecosystem services across linked habitats. UNEP World Conservation Monitoring Centre, Cambridge, UK. [www.unep.org/pdf/Framing\\_the\\_Flow\\_lowres\\_20final.pdf](http://www.unep.org/pdf/Framing_the_Flow_lowres_20final.pdf) (accessed 31 July 2014).
- Sherrouse, B.C.; Clement, J.M.; Semmens, D.J. 2011: A GIS application for assessing mapping, and quantifying the social values of ecosystem services. *Applied Geography* 32(2): 748–760.
- Sherrouse, B.C.; Semmens, D.J. 2012: Social values for ecosystem services, version 2.0 (SOLVES 2.0): documentation and user manual. U.S. Geological Survey Open-File Report 2012–1023. US Geological Survey, Reston, Virginia, USA.
- 55 p. <http://pubs.usgs.gov/of/2012/1023/contents/OF12-1023.pdf> (accessed 31 July 2014).
- van Ripper, C.J.; Kyle, G.T.; Sutton, S.G.; Barnes, M.; Sherrouse, B.C. 2012: Mapping outdoor recreationists' perceived social values for ecosystem services at Hinchinbrook Island National Park, Australia. *Applied Geography* 35: 164–173.
- Villa, F.; Bagstad, K.; Johnson, G.; Voigt, B. 2011: Scientific instruments for climate change adaptation: estimating and optimizing the efficiency of ecosystem service provision. *Economía Agraria y Recursos Naturales* 11(1): 105–128.

# Appendix 2

## Data categories

Datasets, data sources, data portals and information services in Data Supplements 1 & 2 (available for download from [www.doc.govt.nz](http://www.doc.govt.nz) in association with this document) were placed into categories according to data type, biome, scale and relevance to various ecosystem services (summarised in Table A2.1). Note that the colours used in this table reflect the colours used in the data supplements.

Table A2.1 Details of categories (data type, biome, scale and relevance to various ecosystem services) used to assess datasets, data sources, data portals and information services in Data Supplements 1 & 2.

NAME		DESCRIPTION
Data type	Ecological & biodiversity	Data describing the environment, ecosystems and biodiversity, such as land use, land cover, habitat, species distributions, species observation data*, ecosystem classifications and other biophysical data.
	Historic heritage	Historic places, assets and artefacts, archaeological features, and fossils.
	Human activities & built infrastructure	<ul style="list-style-type: none"> <li>Infrastructure, amenities, businesses, resource consents, concessions, permits, events, and human demographic and population data can be used to estimate accessibility or where humans are deriving benefits from services (e.g. guided whale-watching operators are situated where whales can be viewed and enjoyed by humans).</li> <li>Operational and management activities may have negative or positive impacts on ecosystem services and in the future could be used to assess whether management priorities coincide with ecosystem service priorities.</li> <li>Administrative &amp; human-constructed boundaries.</li> </ul>
	Ecosystem service	Projects, databases or data that specifically address ecosystem services. (Note: Other data type categories may not be specified for these entries.)
Biome	Terrestrial	
	Freshwater	
	Estuarine	
	Marine	
Scale		Data are available at a global, national, regional or local scale.
Ecosystem service <sup>†</sup>	1. Natural features	These may be used as indicators of ecosystem service values (e.g. some waterfalls are tourist attractions because of their aesthetic beauty).
	2. Scenery & inspiration	Aesthetic values and inspiration for artworks and crafts.
	3. Multiple services/values	Studies, datasets or data portals that address multiple ecosystem services or values. (Note: Other ecosystem service categories may not be specified for these entries.)
	4. Economic values	Economic valuation; services and goods with economic or commercial value.
	5. Recreation & tourism <sup>†</sup>	
	6. Water supply	
	7. Food & fibre	
	8. Energy	Energy generation, including for wind, solar, hydro, geothermal, coal and natural gas.
	9. Erosion control	
	10. Pollination	
	11. Climate & air	Carbon sequestration and storage, climate regulation, air quality, and weather.
	12. Historic ecosystems	These may have provided services from which we still derive benefits today, but the supply of these benefits may not be perpetual.
	13. Geology	Information on geology, soils, soil services and geological resources (e.g. petroleum, rocks and minerals that have economic and other benefits).
	14. Covenants/volunteering	Community and volunteer conservation programmes and conservation covenants show where people value and receive benefits from natural and/or historic heritage.
	15. Māori values	Services and benefits of value to traditional Māori culture.
	16. Sun	Benefits of sun exposure and protection against its harmful effects. For example, Vitamin D synthesis in humans is enabled by sun exposure. However, the ozone layer provides protection against harmful ultraviolet radiation.

Continued on next page



Table A2.1 continued

NAME	DESCRIPTION
17. Habitat & primary production	These are supporting or provisioning services.
18. Nutrient retention	
19. Natural hazards & disasters	Protection against or mitigation/reduction of storms, floods, fires and natural disasters.

\* Some biological data can be derived from web-based public participatory mapping services, where members of the public can upload their nature observations. These observations can be reinterpreted as locations where people are engaging with nature and subsequently gaining cultural benefits such as learning and recreational enjoyment.

† This includes activities that directly involve introduced species, such as hunting or fishing. Gidlow et al. (2009) found that the main reason that recreational hunters, fishers and divers participated in their preferred outdoor recreational activity was 'being in natural environments'. Similarly, Kerr (2012) found that the main reason to hunt was to enjoy the outdoors.

‡ Ecosystem service categories do not necessarily match a particular ecosystem service typology such as those followed by the Economics of Ecosystems and Biodiversity (TEEB), the Millennium Ecosystem Assessment (MA), the National Ecosystem Assessment (NEA) or the Common International Classification of Ecosystem Services (CICES). Rather, these categories were chosen to best describe the data identified during the stocktake.

#### References

- Gidlow, B.; Cushman, G.; Espiner, S. 2009: Recreational hunters, fishers and divers in North Canterbury: outdoor enthusiasm in social contexts. *LEaP Report No. 8*. Lincoln University, Lincoln, New Zealand. 71 p.
- Kerr, G.N. 2012: Lincoln University Hunting Survey. Presentation to The Tahr Show, 4–5 August 2012, Christchurch, New Zealand. 1 p. [www.lincoln.ac.nz/Documents/hunt/LU-Hunting-Survey-results-poster.pdf](http://www.lincoln.ac.nz/Documents/hunt/LU-Hunting-Survey-results-poster.pdf) (accessed 31 July 2014).

# Appendix 3

## How many people drink water that at least partly originates from lakes whose catchments are dominated by natural land cover?

### Data requirements:

1. Freshwater Ecosystems of New Zealand (FENZ) lake catchment feature class
2. National Environmental Standards (NES) for Sources of Human Drinking Water database

### Description of process (using ArcGIS):

1. Select and export all lake water sources from the NES Sources of Human Drinking Water database to a new features class. A source was assumed to be a lake if: (i) source type = 'lake' or 'dam'; and/or (ii) it intersected the FENZ lake feature class (note: the accuracy of lake source identification has not been verified). Only those sources supplying treatment plants that serve populations of at least 501 people were included because it is a legal requirement for these to be registered. Data of interest include:
  - (a) Treatment Plant identification code
  - (b) Treatment Plant population Output = A
2. Use the 'intersect' tool to match lake sources with the FENZ lake catchment feature class, which contains the following data of interest:
  - (a) Lake catchment area
  - (b) Proportion of lake catchment area under natural cover Output = B
3. Use the 'Summary Statistics' tool to calculate the total catchment area for each treatment plant (case field = treatment plant ID). Join the field containing total catchment area to Output B. Calculate the following in a new field:  $Z = \text{catchment area} \div \text{total catchment area for each plant} \times \text{proportion natural cover within catchment}$  Output = B
4. Use the 'Summary Statistics' tool to calculate the sum of Z values for each treatment plant. This will give the average proportion of natural cover of lake catchments for each treatment plant. Use the join field tool to add output B's population field to this table. Output = C
5. Find the mean centre of each treatment plant's sources. To do this, use the 'Mean Center' tool where the input is output B, and the case field is treatment plant ID. Use the join field tool to add to the resulting feature class the fields from output C. Output = D

The same process could be followed for river catchments.

TREATMENT PLANT ID	NO. LAKE SOURCES	AVERAGE PROPORTION OF NATURAL COVER IN LAKE CATCHMENTS	NO. PEOPLE
TP00002	9	0.2092	2381
TP00003	9	0.2092	1696
TP00011	9	0.2092	17105
TP00012	9	0.2092	6396
TP00014	1	0.0746	13500
TP00087	2	0.9557	1857
TP00094	3	0.4152	18000
TP00095	3	0.4152	18000
TP00129	1	0.9922	968576
TP00147	4	0.0811	68085
TP00174	2	0.8091	30600
TP00215	3	0.3905	1268
TP00216	3	0.4072	8700
TP00352	4	0.3579	59072
TP00393	1	0.9007	56530
TP00440	9	0.2092	1883
TP00602	9	0.2092	739
TP02905	3	0.4072	8700
TP02906	3	0.4072	9000